



Free Downloads of Build Instructions,
Assembly Booklets & How To Guides

BuildInstructions.com

WARHAMMER 40,000

PIETY AND PAIN

ZEALOUS BLOODSHED IN THE 41ST MILLENNIUM



! READ THIS FIRST | À LIRE EN PRIORITÉ | BITTE BEACHTE | LEE ESTO PRIMERO | LEGGI PRIMA QUESTO | 最初にお読みください。| 请优先阅读

ENG BEFORE ASSEMBLING YOUR MINIATURES, PLEASE READ THROUGH THE INSTRUCTIONS IN THIS BOOKLET CAREFULLY. A pair of plastic cutters is required to remove the plastic components in this kit from their frame. We advise using a mouldline scraping tool to clean up the parts. To assemble your model you will need plastic glue. Games Workshop sells Citadel Fine Detail Cutters, Citadel Mouldline Remover and Citadel Plastic Glue, but does not recommend these products for use by children under the age of 16 without adult supervision.

FRE AVANT D'ASSEMBLER VOS FIGURINES, VEUILLEZ LIRE ATTENTIVEMENT LES INSTRUCTIONS DE CE LIVRET. Une pince coupante est requise pour détacher chaque élément de sa grappe. Nous vous recommandons l'utilisation d'un grattoir pour ébarber les éléments. Pour l'assemblage, vous aurez également besoin de colle plastique. Games Workshop commercialise les Pinces de Précision Citadel, l'Ébarboir Citadel et la Colle Plastique Citadel, mais n'en recommande pas l'utilisation pour des enfants de moins de 16 ans sans la supervision d'un adulte.

ESP POR FAVOR, LEE CUIDADOSAMENTE ESTE LIBRETO DE INSTRUCCIONES ANTES DE EMPEZAR A MONTAR LAS MINIATURAS. Te harán falta unas tenazas para plástico a fin de separar las piezas de la matriz. También aconsejamos una herramienta para rebabas a fin de limpiar cada pieza. Para montar la miniatura necesitarás pegamento para plástico. Games Workshop vende Tenazas Citadel, Herramientas para rebabas Citadel y Pegamento para plástico Citadel, pero no recomienda estos productos a menores de 16 años sin la supervisión de un adulto.

GER VOR DEM ZUSAMMENBAU DER MINIATUREN BITTE DIE ANWEISUNGEN IN DIESER ANLEITUNG AUFMERKSAM DURCHLESEN. Du benötigst einen Kunststoffseitenschneider, um

die Kunststoffbauteile aus dem Gussrahmen herauszutrennen, und Kunststoffkleber, um die Miniatur zusammenzubauen. Außerdem empfehlen wir, die Bauteile vorher mit einem Gussgratentferner zu säubern. Games Workshop bietet Präzisions-Kunststoffseitenschneider von Citadel sowie Citadel-Kunststoffkleber an, empfiehlt aber, dass Kinder unter 16 Jahren diese nur unter Aufsicht eines Erwachsenen benutzen.

ITA PRIMA DI ASSEMBLARE LE TUE MINIATURE LEGGI ATTENTAMENTE TUTTE LE ISTRUZIONI DI QUESTO LIBRETTO. Sono necessarie un paio di tronchesine per plastica per staccare i componenti dai loro sprue. Consigliamo di usare un attrezzo apposito per pulire i componenti. Per assemblare il modello avrai bisogno di colla per plastica. Games Workshop vende Tronchesine di precisione Citadel. Attrezzo per ripulire Citadel e Colla per plastica Citadel, ma non consiglia questi prodotti ad un pubblico minore di 16 anni senza la supervisione di un adulto.

日本語 本キット内のフレームからプラスチックパーツを切り離すためには、ニッパーが必要です。パーツのモールドを平らにするには、専用ツールの使用をお勧めいたします。本キットの組み立てには、プラ用接着剤が必要です。ゲームズワークショップはシタデル・ニッパー、プラ用接着剤、シタデル・モールドラインリムーバーを販売しておりますが、16歳以下の子供が大人の監督なしにこれらの道具を使用されることをお勧めしません。

中文 你需要一把模型剪将塑料部件从板上剪下来。我们建议使用分模线刮刀来处理零件。组装时你还需要用到模型胶水。你可以从 Games Workshop 处购买到 Citadel Fine Detail Cutter 模型剪、Citadel Mouldline Remover 分模线刮刀和 Citadel Plastic Glue 模型胶，但 16 岁以下儿童不得在没有成年人监护的情况下使用这些产品。

- | | | | |
|---|---|--|--|
| <p>!</p> <ul style="list-style-type: none"> • Special instruction - Please read • Instructions spéciales - Lire attentivement • Instrucción especial: Por favor, léela • Besondere Anweisung - Bitte lesen • Istruzioni speciali - Leggi attentamente • 特記事項 - 必ずお読みください • 特殊说明 - 请详阅 | <p>⚙️</p> <ul style="list-style-type: none"> • Variant assembly • Variante d'assemblage • Variante de montaje • Bauvariante • Assemblaggio alternativo • 組み立てバリエーション • 多种组装方式 | <p>⚡</p> <ul style="list-style-type: none"> • Use matching parts • Utiliser les éléments correspondants • Usa las piezas que correspondan • Verwende die passenden Teile • Usa le parti corrispondenti • 適合するパーツを使用 • 使用匹配部件 | <p>🖌️</p> <ul style="list-style-type: none"> • Paint before assembly • Peindre avant assemblage • Pintar antes del montaje • Erst bemalen, dann zusammenbauen • Dipingi prima dell'assemblaggio • 組み立て前にペイントすること • 组装前涂装 |
| <p>▶</p> <ul style="list-style-type: none"> • Dry fit stage before gluing • Tester avant de coller • Comprobar el encaje antes de pegar • Positionierung erst ohne Klebstoff ausprobieren • Prova a secco prima di incollare • 接着前にぴったり合わせること • 粘接前的假组阶段 | <p>🔄</p> <ul style="list-style-type: none"> • Choice of parts • Choix d'éléments • Modelos de componentes • Auswahl an Teilen • Scelta di componenti • パーツの選択 • 选择部件 | <p>x2</p> <ul style="list-style-type: none"> • Repeat process • Répéter l'étape • Repetir pasos • Vorgang wiederholen • Ripeti il processo • 同じ作業を繰り返すこと • 重复步骤 | <p>✅</p> <ul style="list-style-type: none"> • Stage complete • Étape terminée • Paso completado • Schritt abgeschlossen • Fase completa • このステージの完成 • 完成 |

CONTENTS | CONTENU | CONTENIDO | INHALT | CONTENUTO | コンテンツ | 内含板件

A x1



B x1

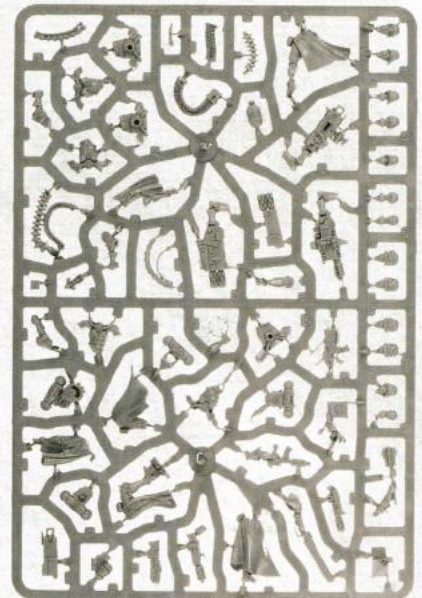

C x1

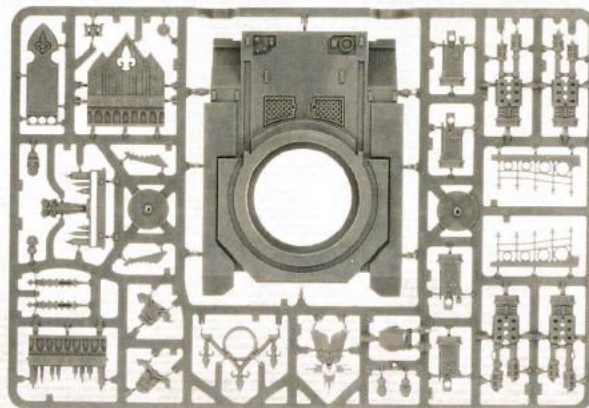
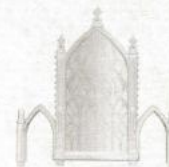
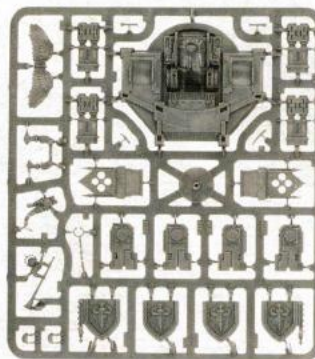
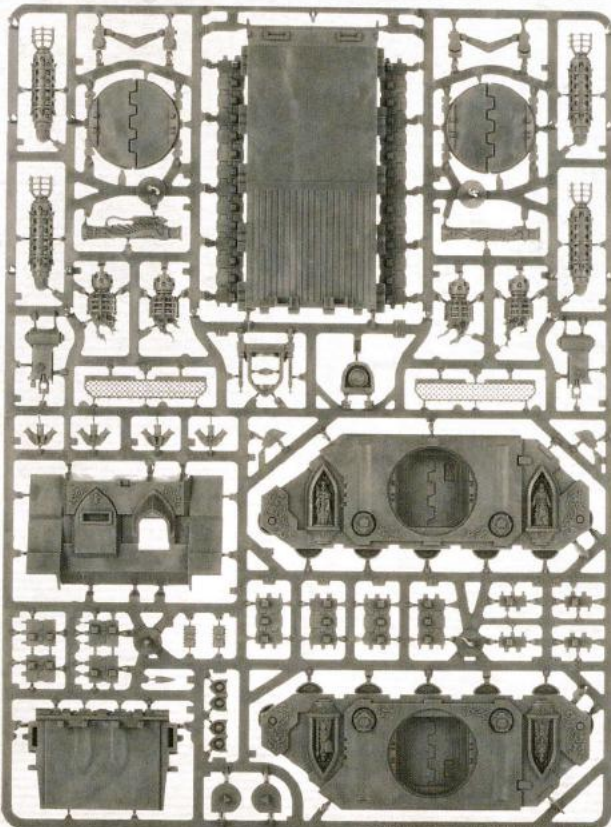

D x1



E x1

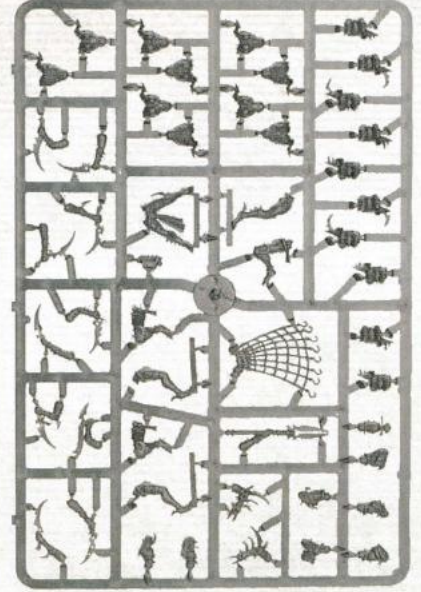
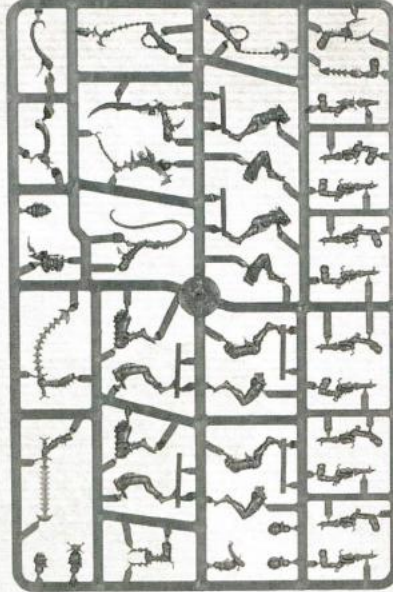

F x1

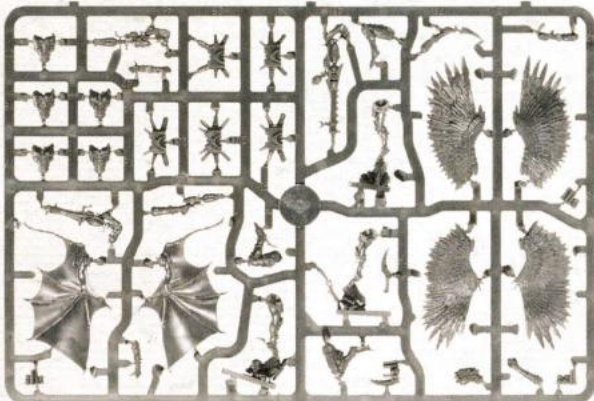

G x1

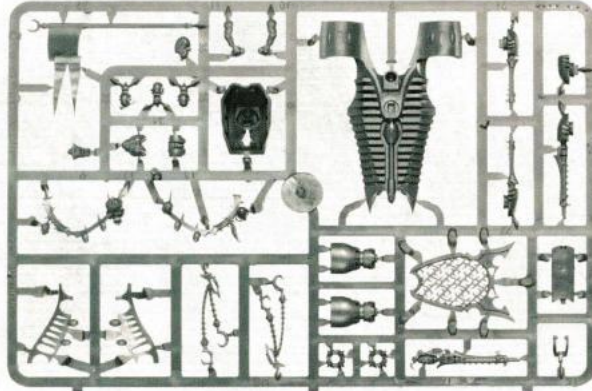
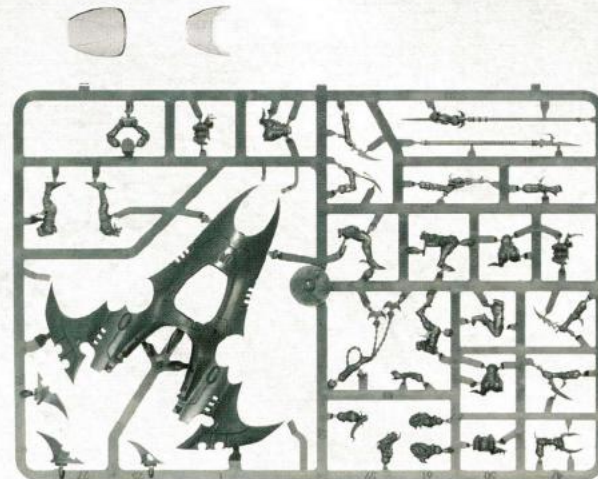

1:2



x12



x12

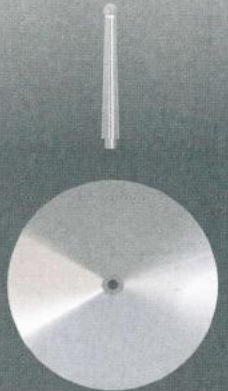

BUILD VARIANTS | VARIANTES D'ASSEMBLAGE | MONTA TERNATIVOS | BAUVARIANTEN | VARIANTI D'ASSEMBLAGGIO | バリエーション | 変体版



- Assemblies for build variants are colour coded.
- Les assemblages de variantes ont un code couleur.
- Las instrucciones para montajes alternativos se indican con un color diferente.
- Optionen für Bauvarianten sind farblich markiert.
- Le diverse varianti d'assemblaggio sono divise per colore.
- バリエーション違いの組み立ては色分けされている。
- 変体版拼装部件有颜色区分。



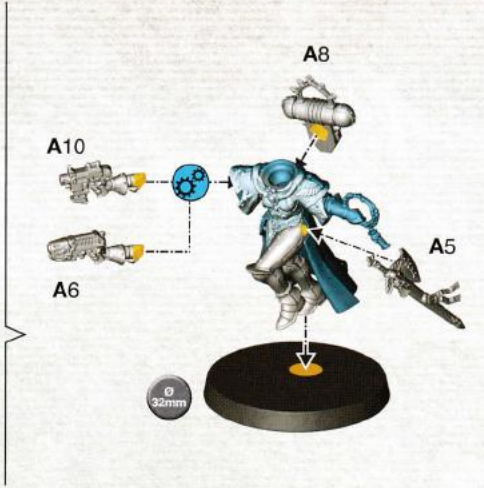
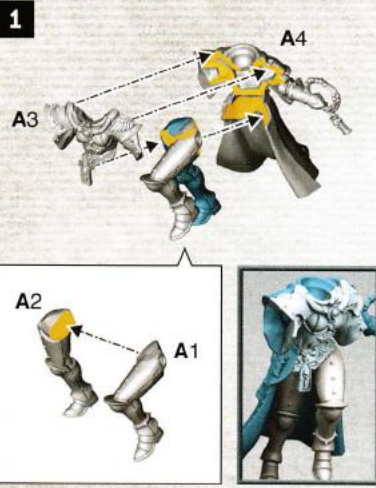

2 - 6 RETRIBUTOR SQUAD | ESCOUADE RETRIBUTOR | ESCUADRA DE VENGADORAS | RETRIBUTORTRUPP | SQUADRA CASTIGANTI
リトリビューター・スカッド | 仇天使小队

2 a Retributor Superior | Retributor Supérieure | Vengadora Superiora | Retributor-Prioris | Castigante Superiora | リトリビューター・スベリオール | 仇天使隊長

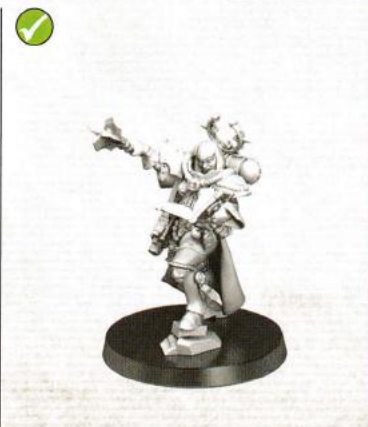
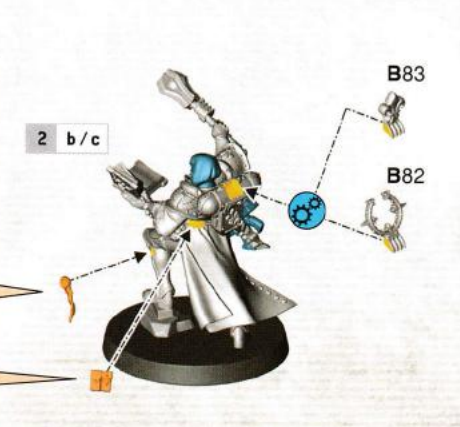
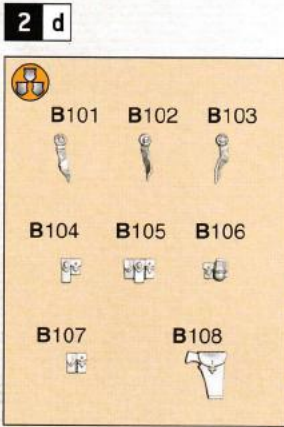
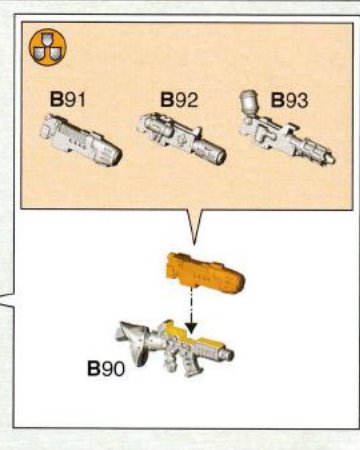
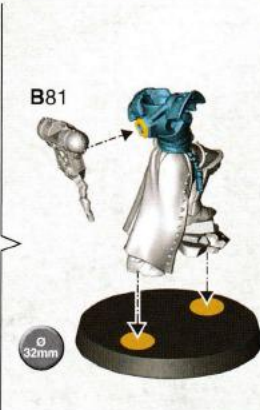
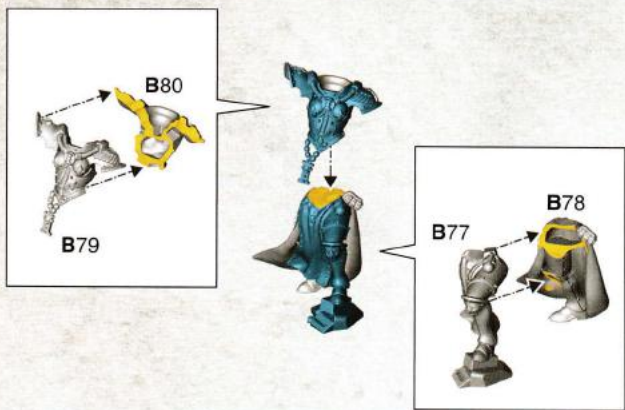

3 a Retributor 1 | Retributor 1 | Vengadora 1 | Retributor 1 | Castigante 1 | リトリビューター 1 | 仇天使 1 **x2**

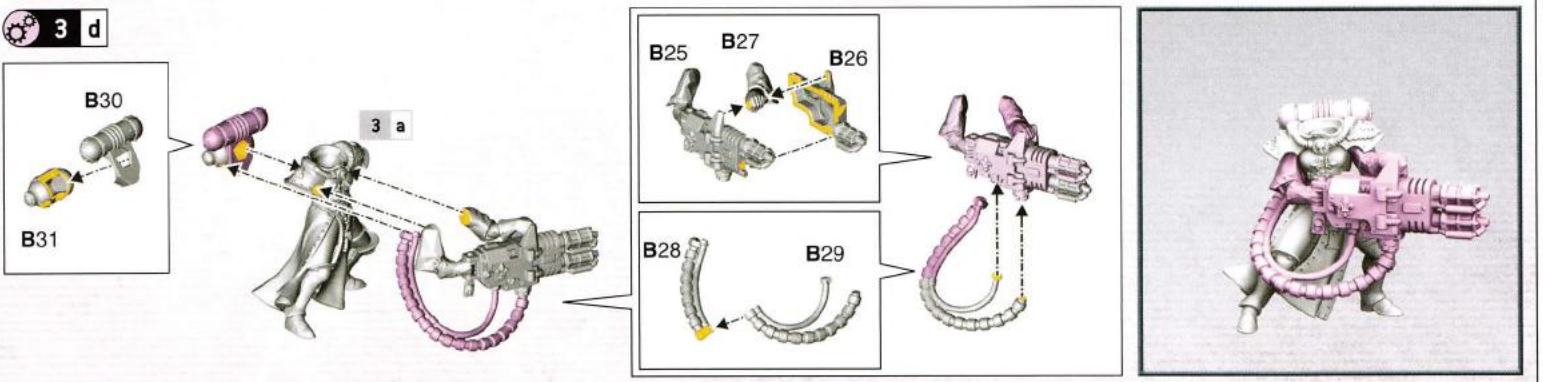
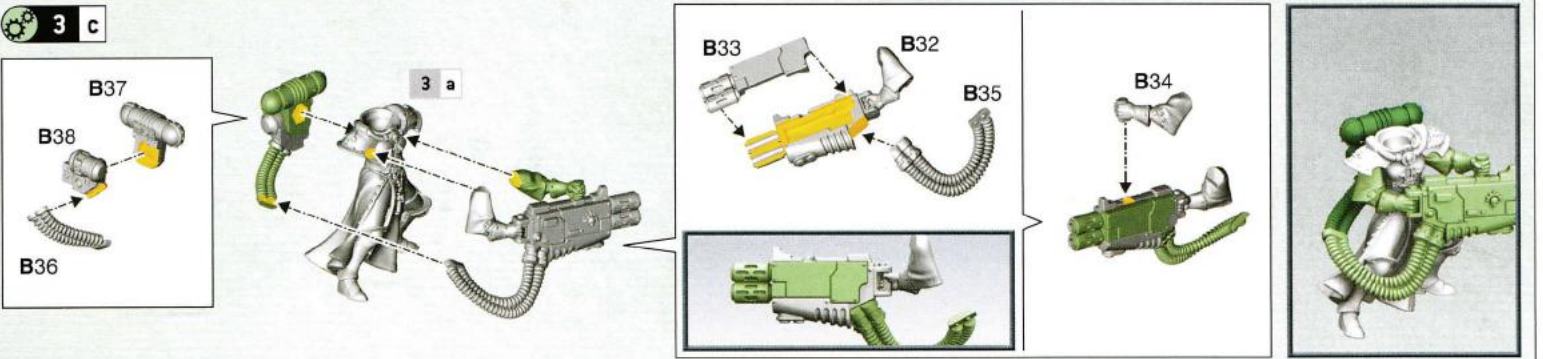
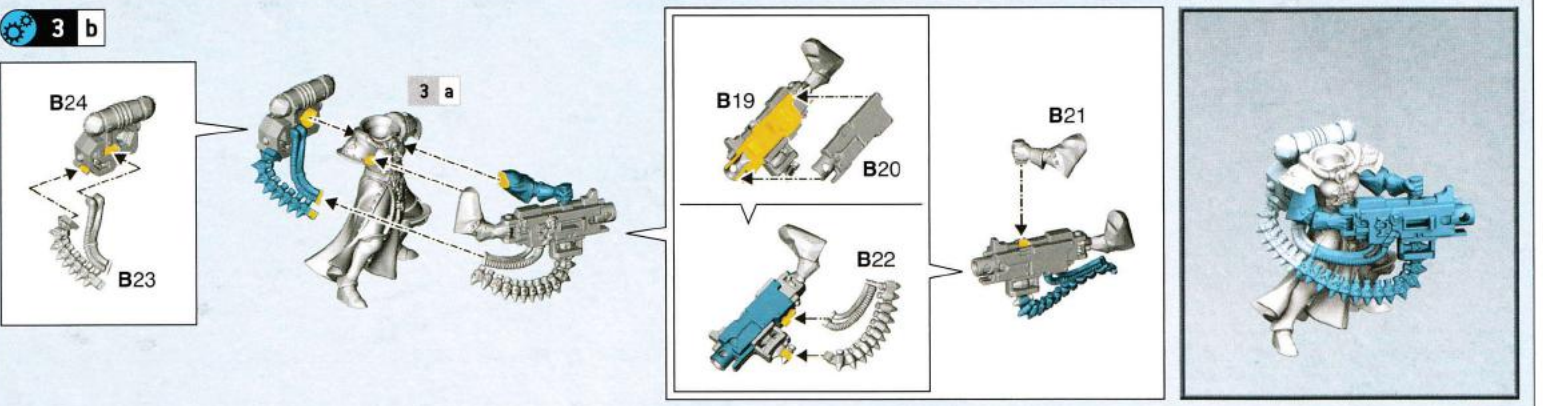
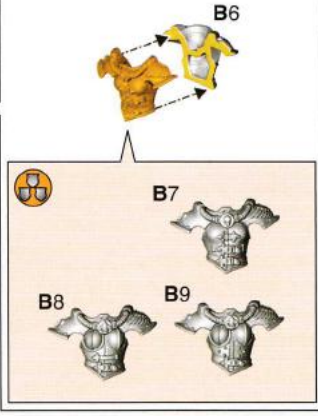
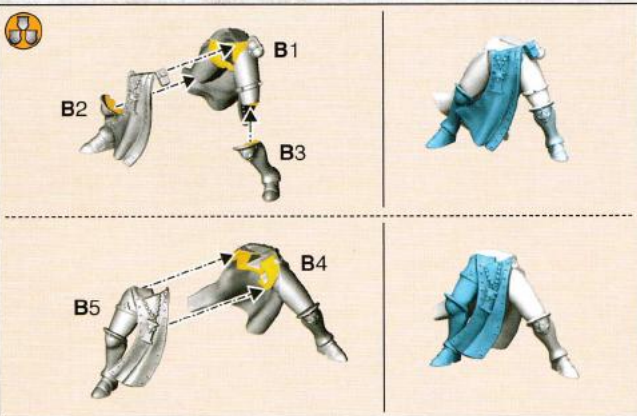

3 e x2

3 b/c

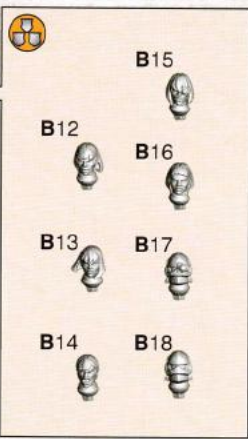

3 d

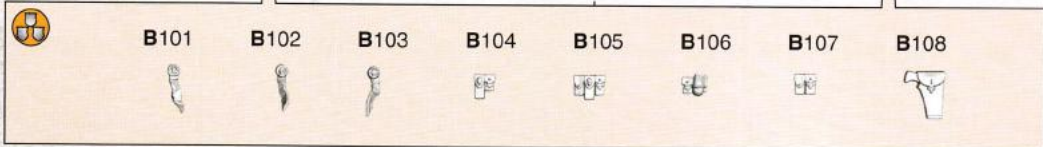
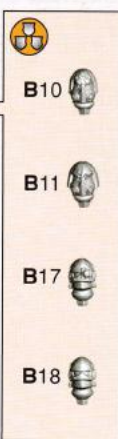

4 a Retributor 2 | Retributor 2 | Vengadora 2 | Retributor 2 | Castigante 2 | リトリビューター 2 | 仇天使 2 x2

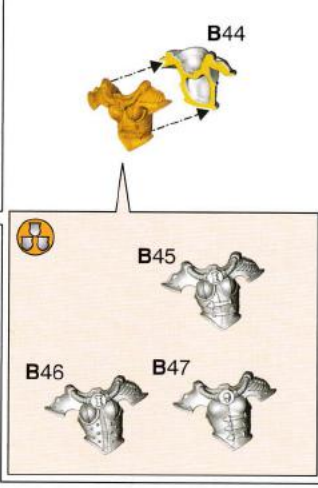
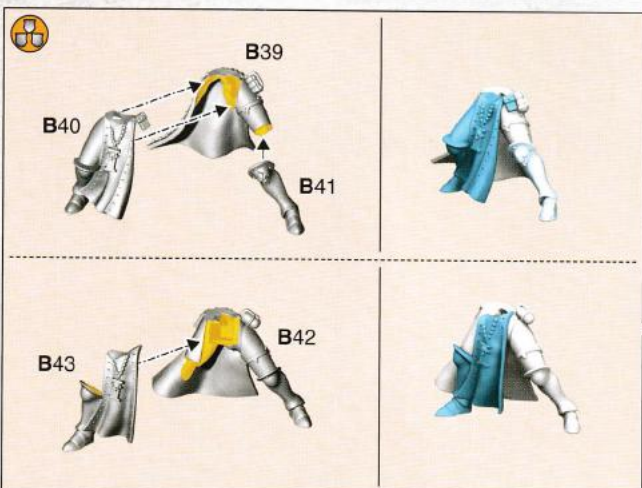

4 b



4 c



4 d



4 b

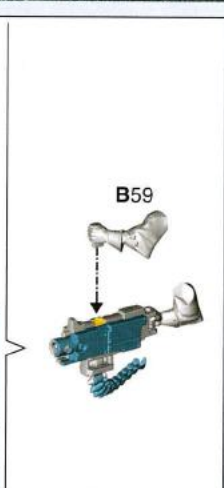
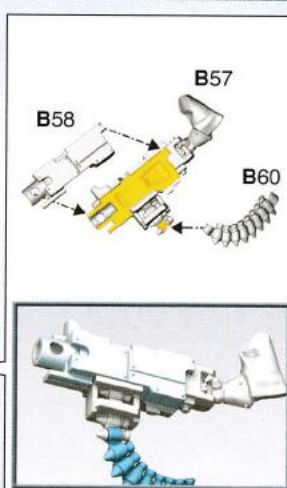
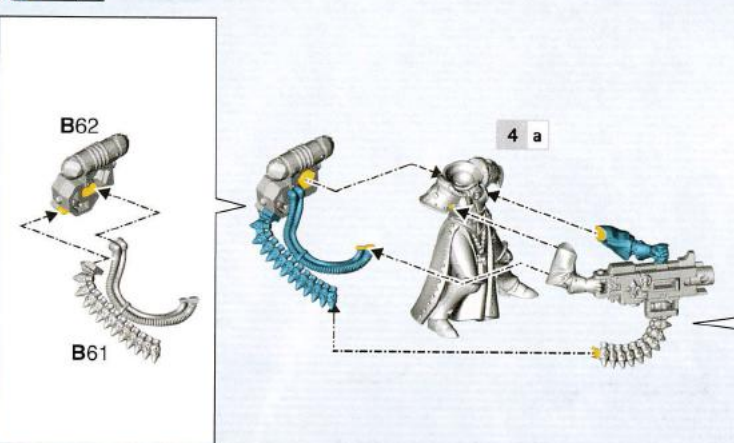

4 c

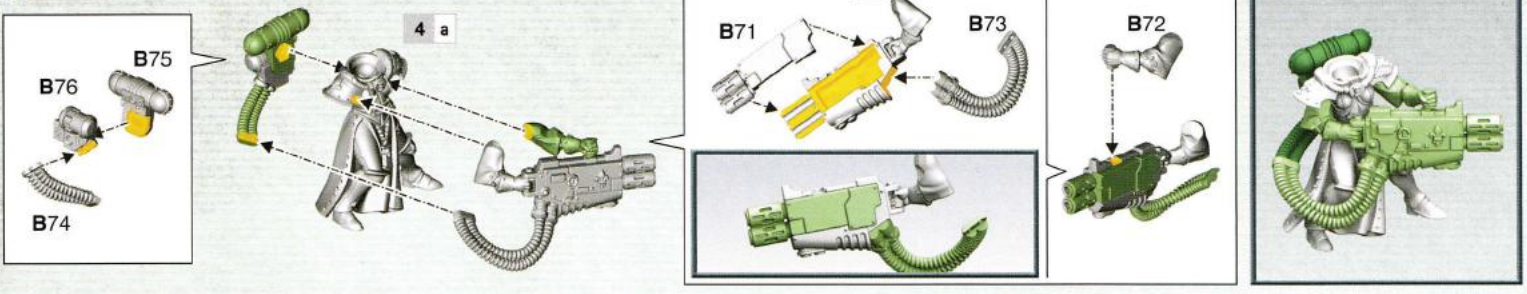

4 d

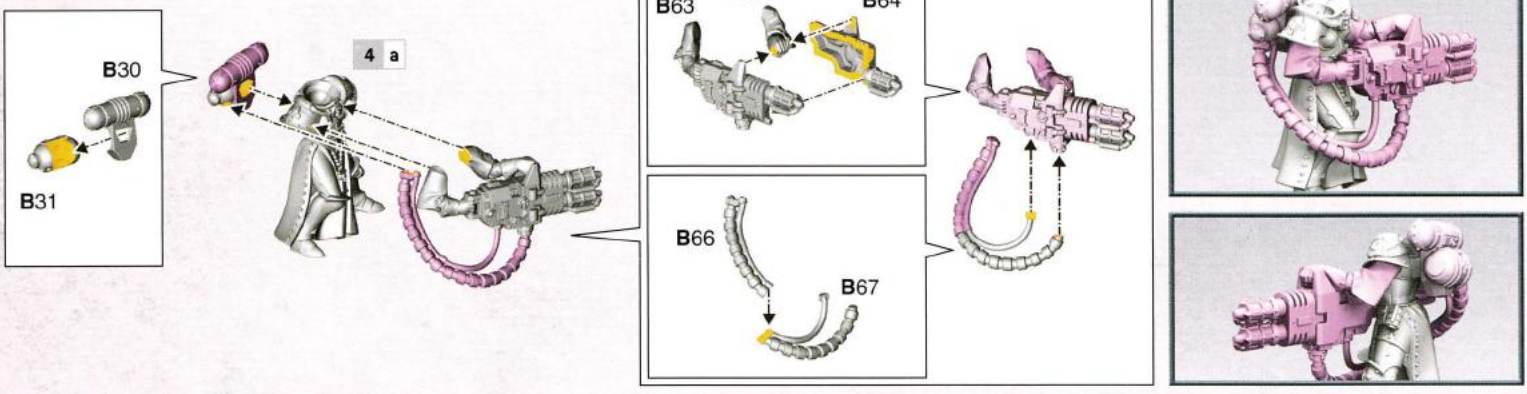

4 e x2

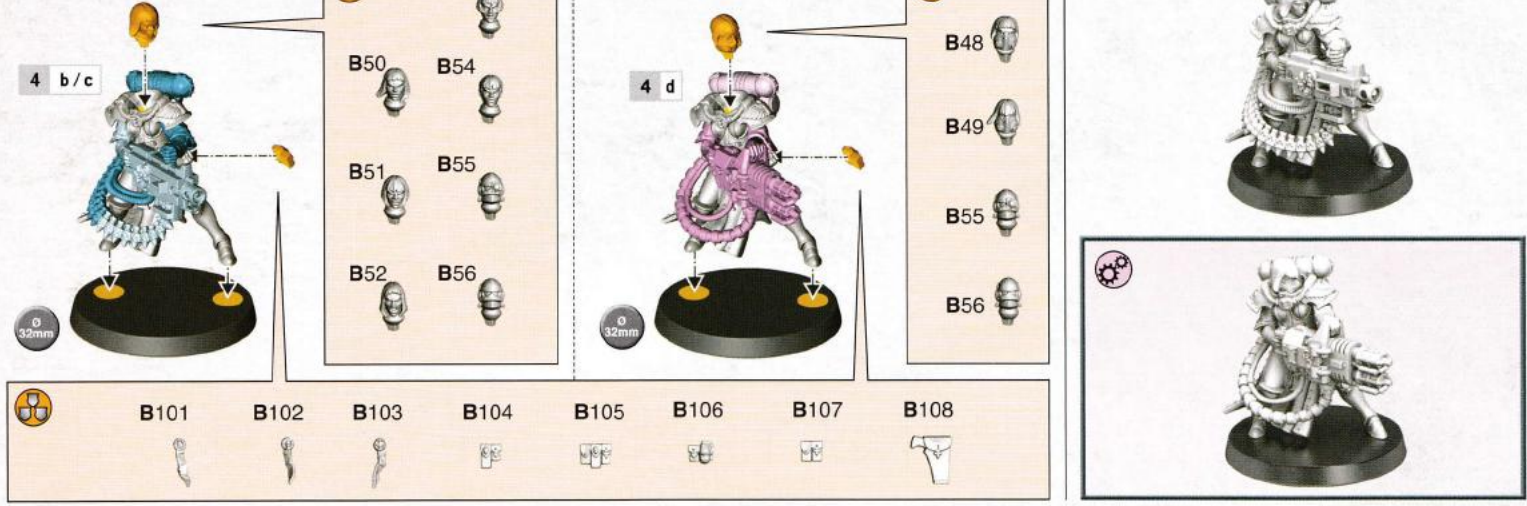

5 Cherub 1 | Chérubin 1 | Querubín 1 | Cherub 1 | Cherubino 1 | ケルプ 1 | 智天使 1

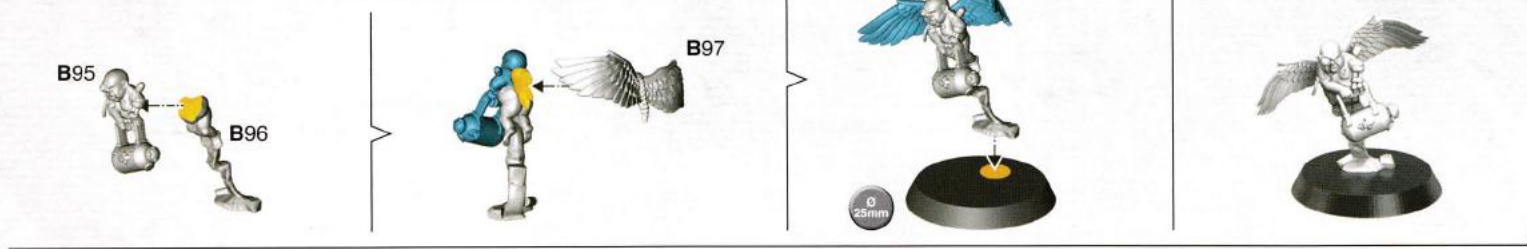

6 Cherub 2 | Chérubin 2 | Querubín 2 | Cherub 2 | Cherubino 2 | ケルプ 2 | 智天使 2



7 a

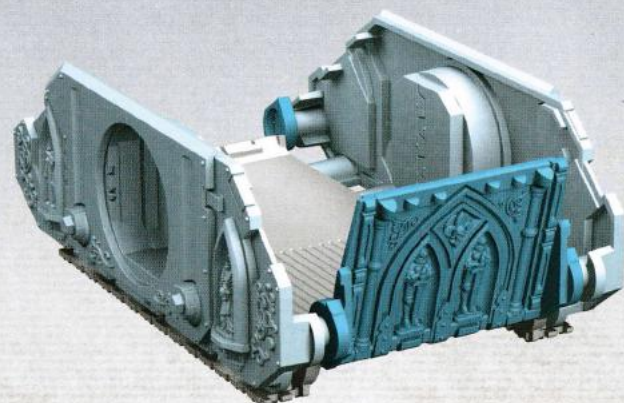
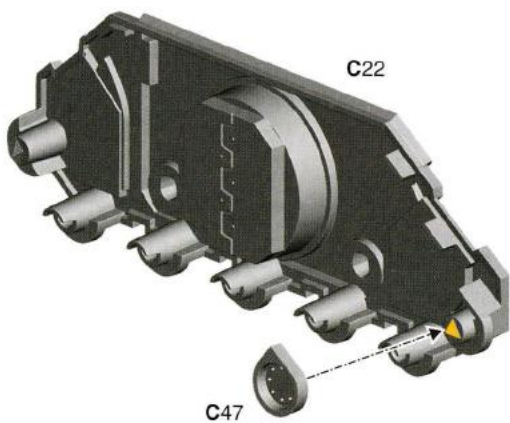
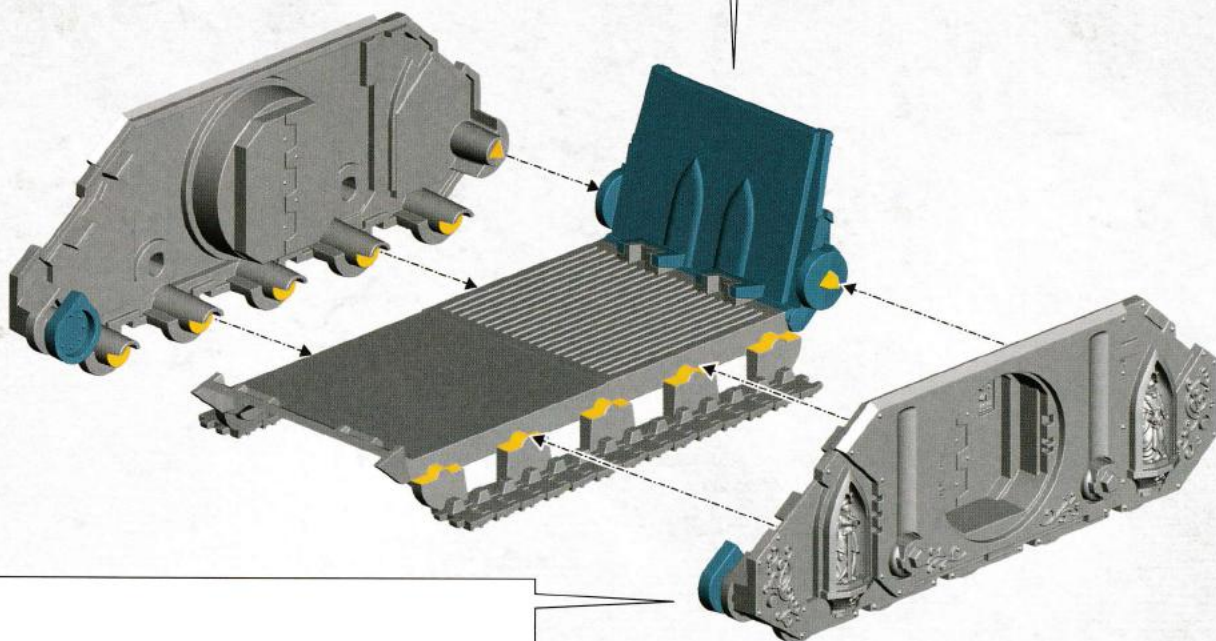
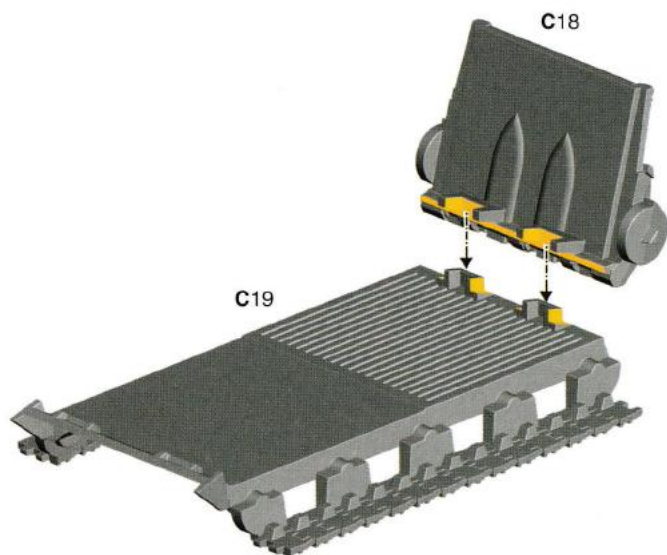
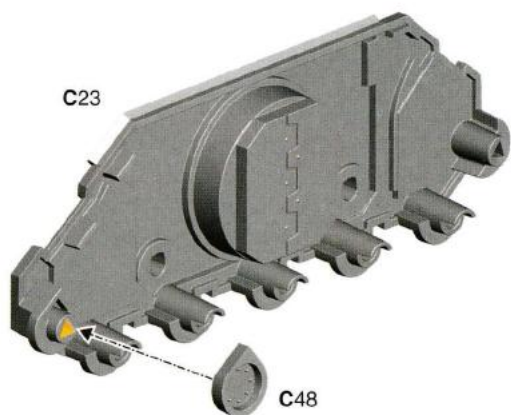

7 b

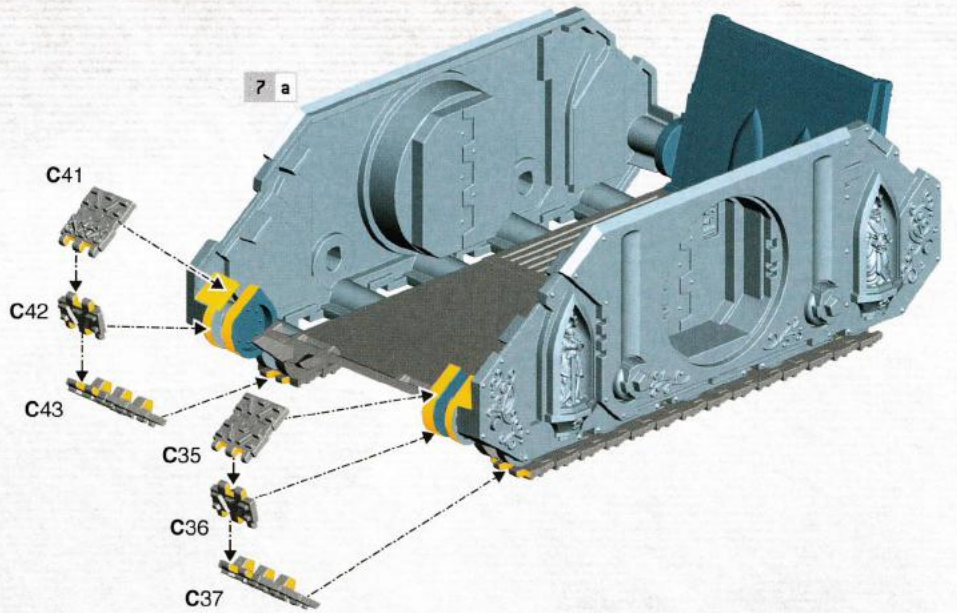
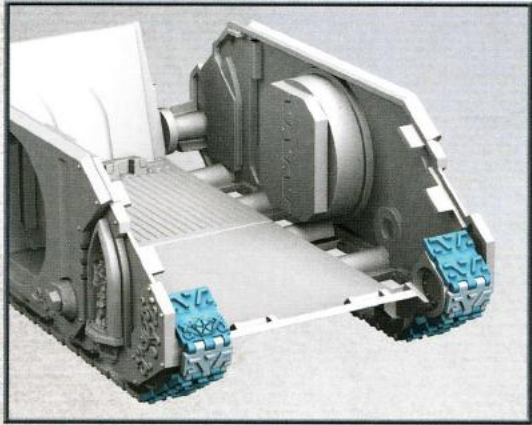

7 c

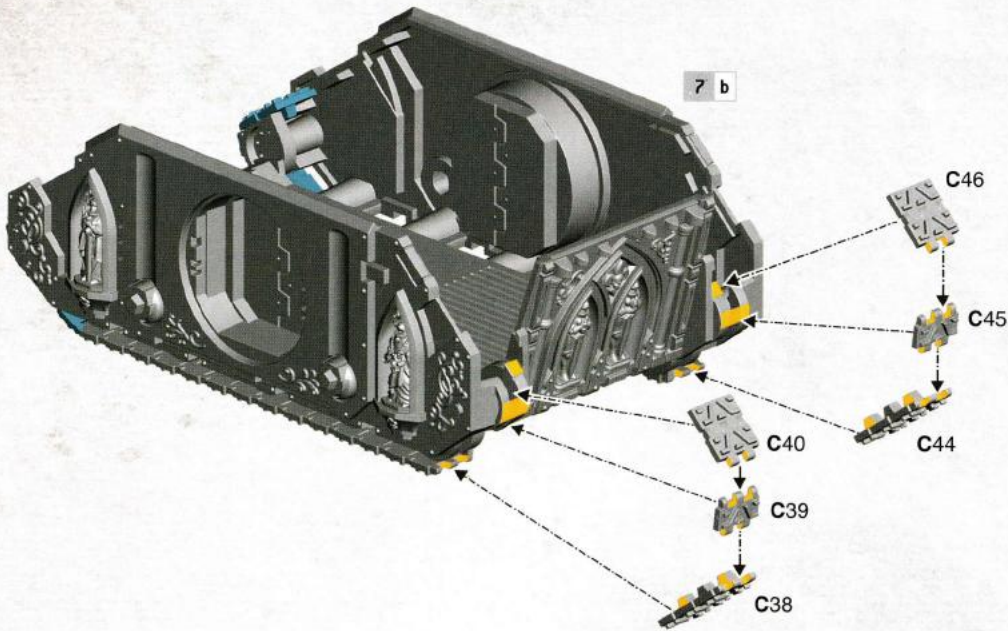

7 d

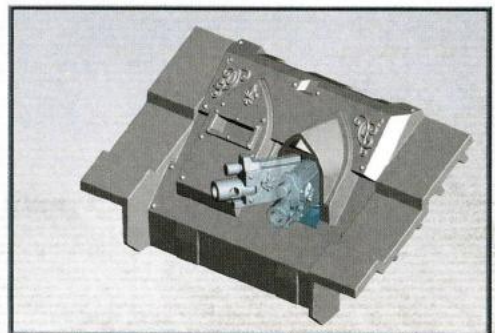
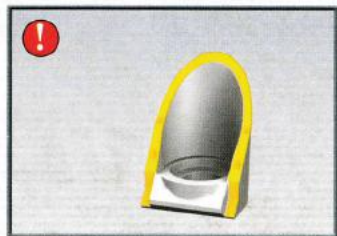
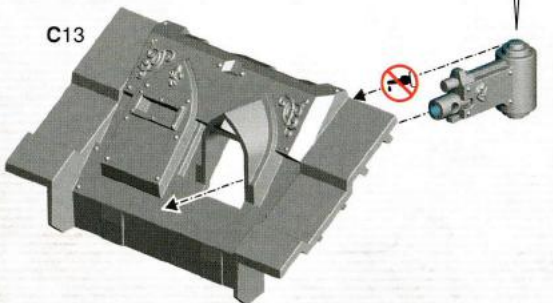
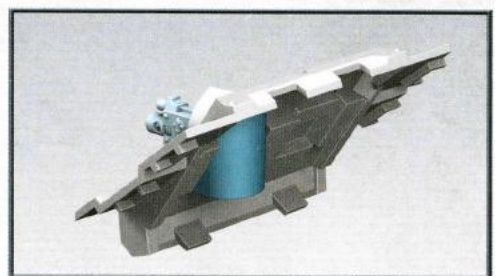
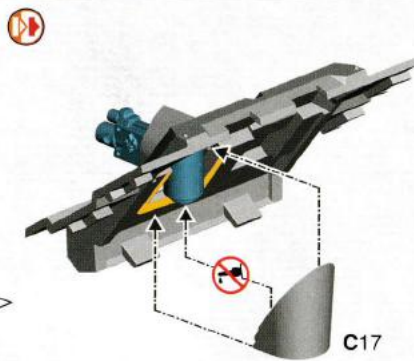
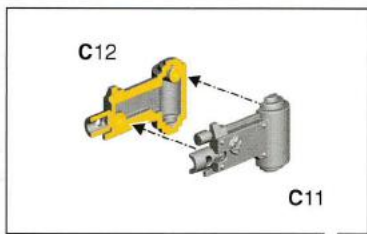

7 e

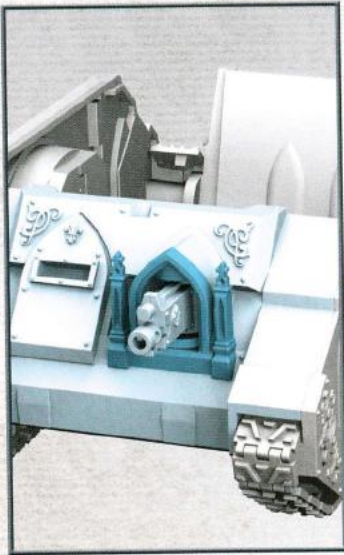

7 d

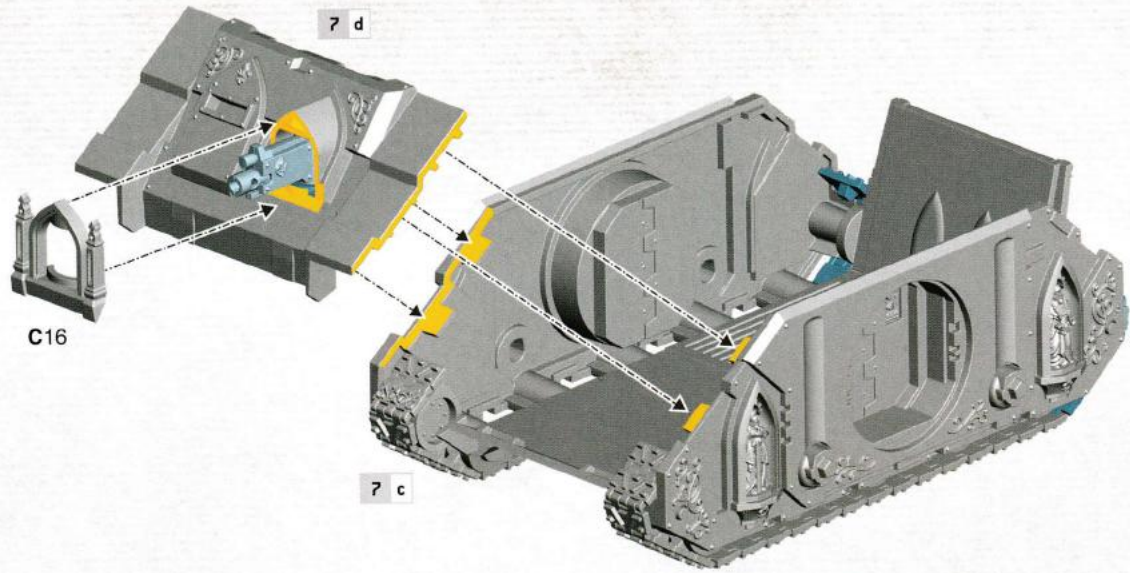

C16

7 c

7 f

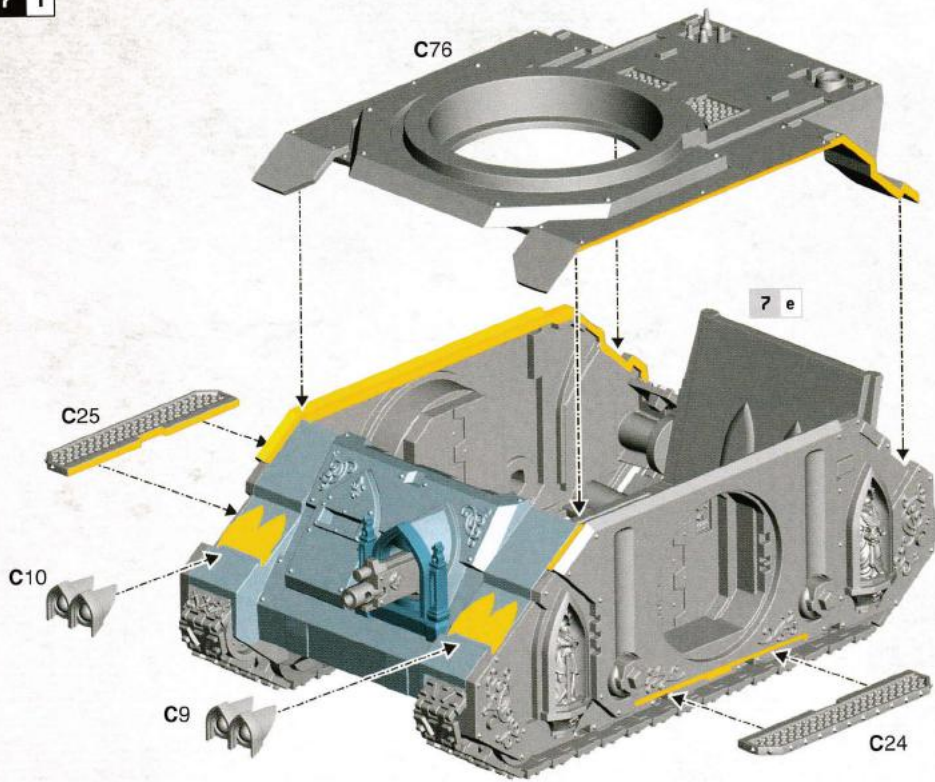

C76

7 e

C25

C10

C9

C24

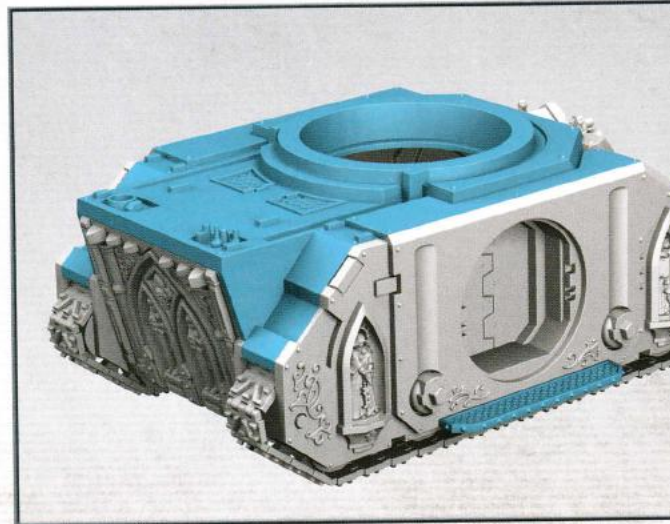
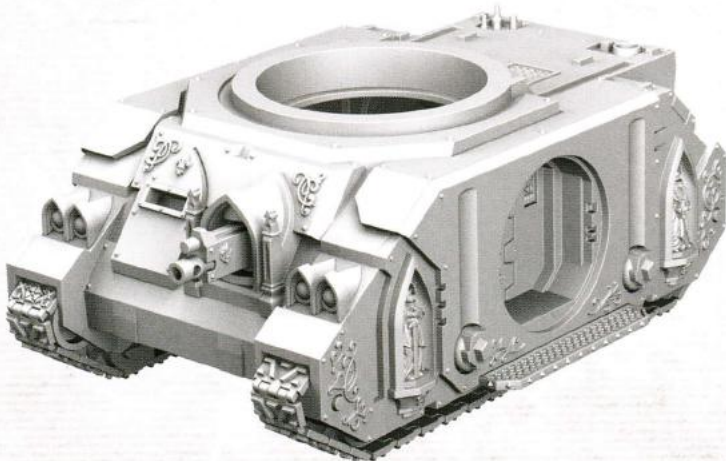
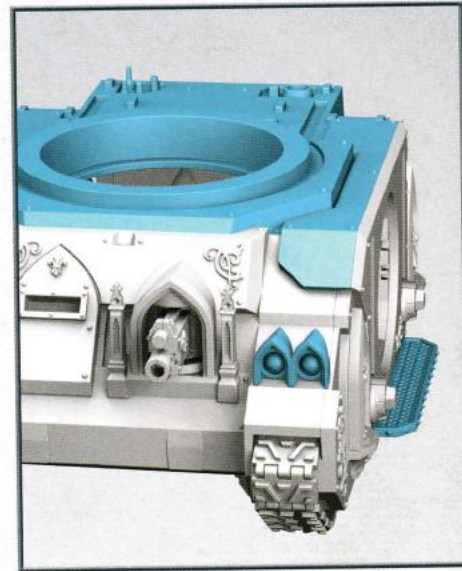

8 a

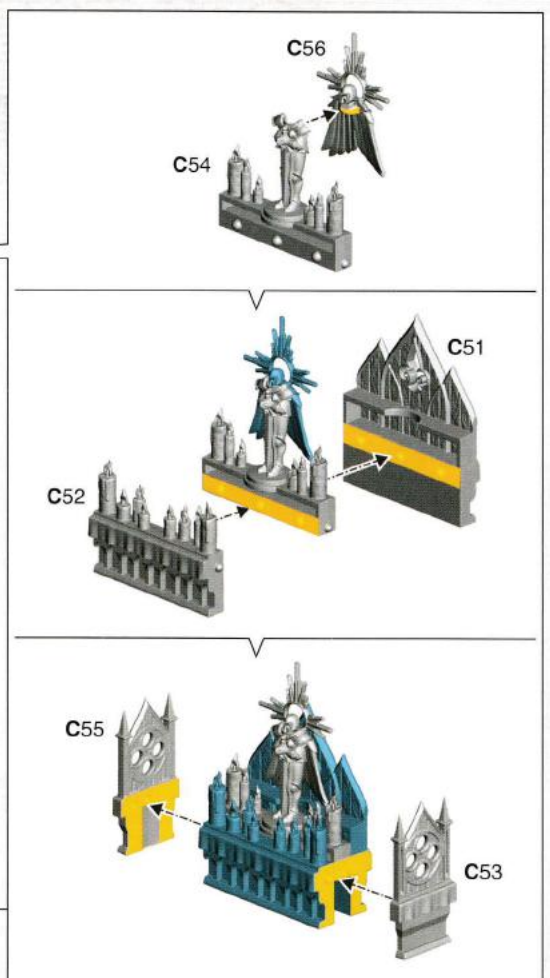
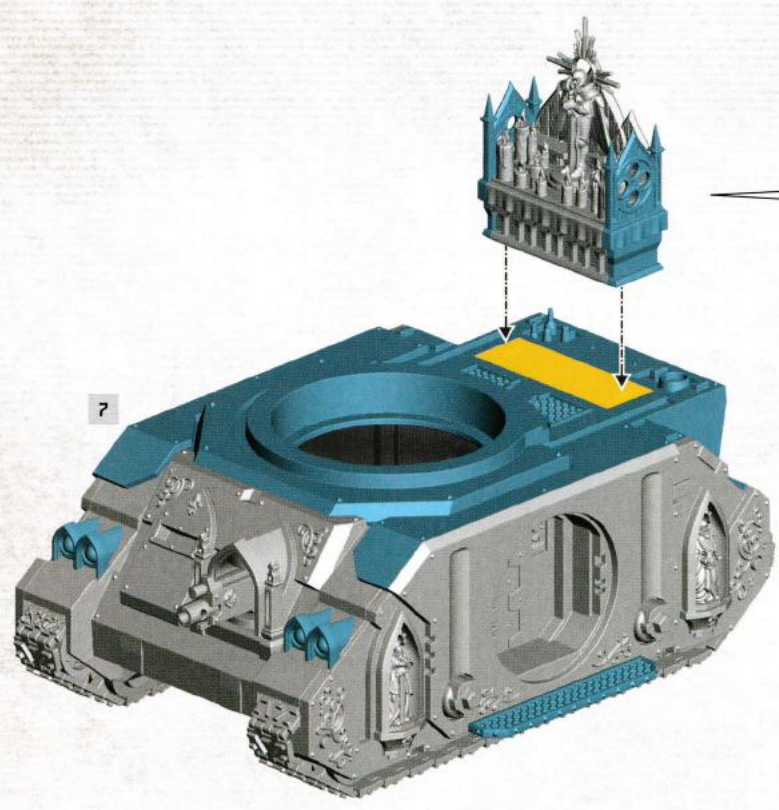

8 b

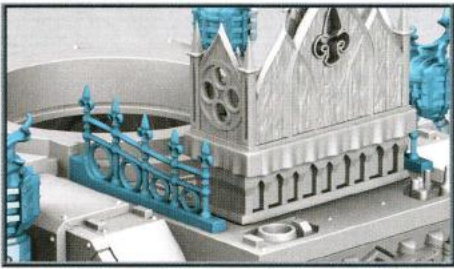
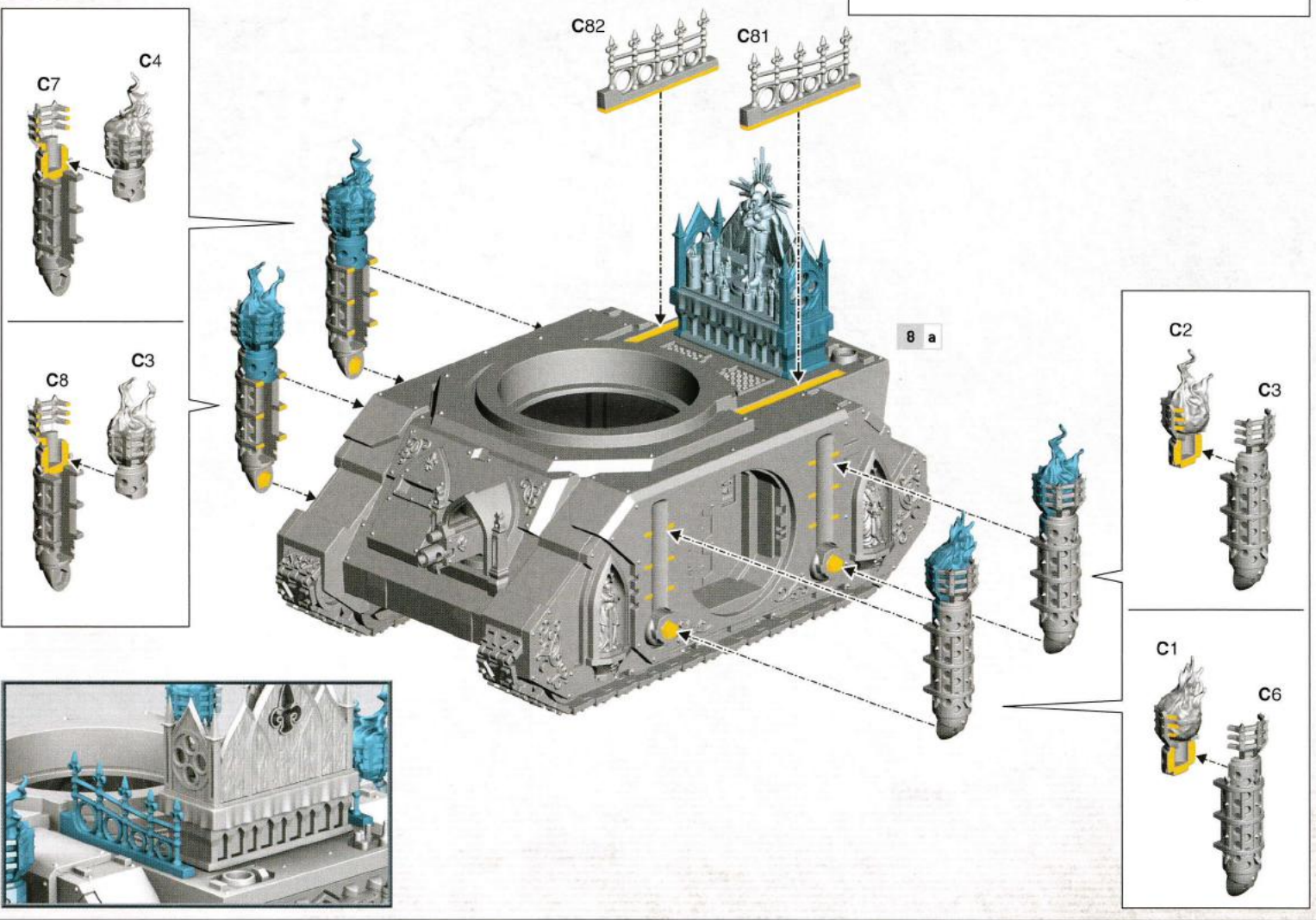

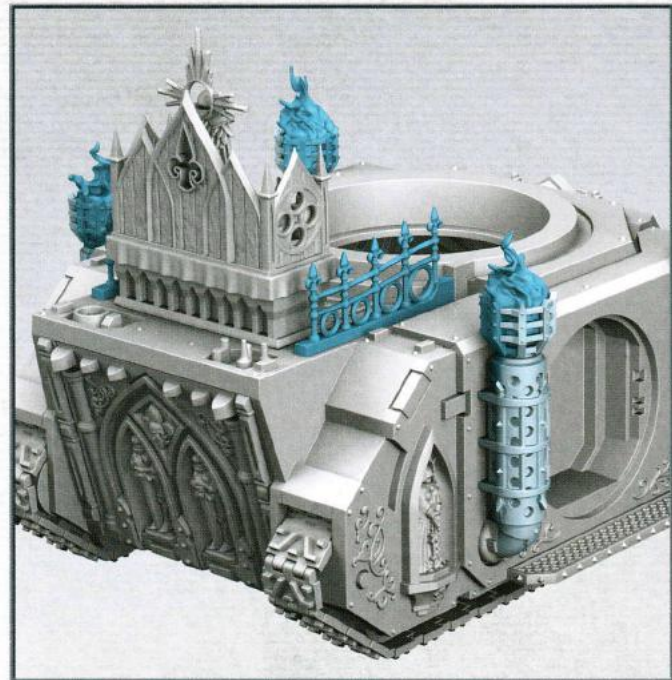
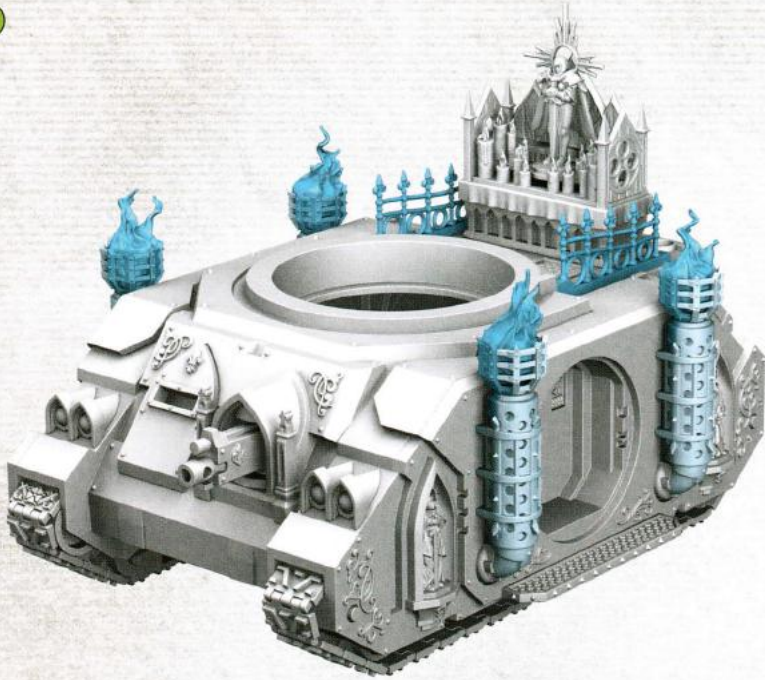

9 a

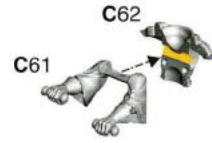
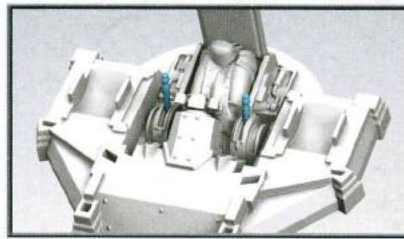
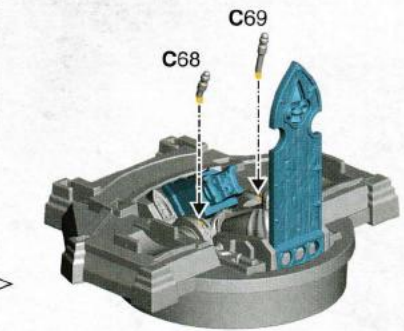
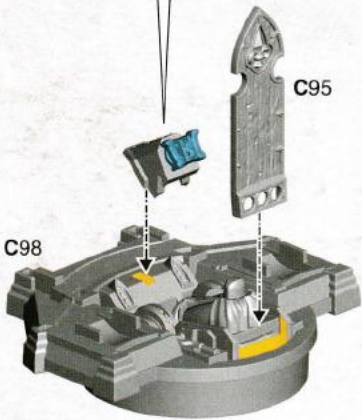

9 b

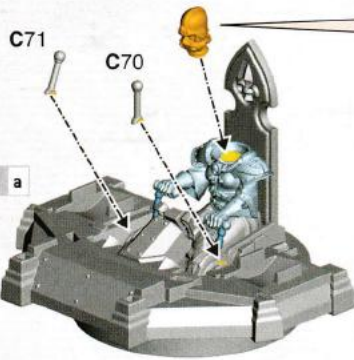

9 a

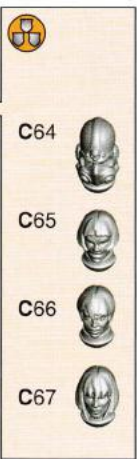

9 c

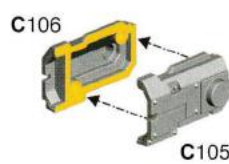

9 b

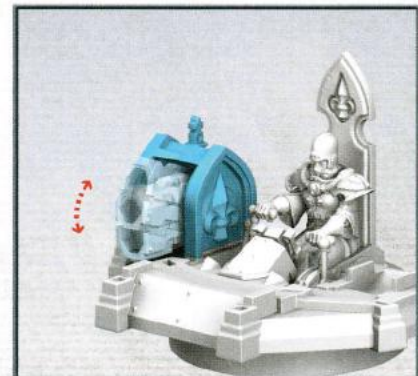
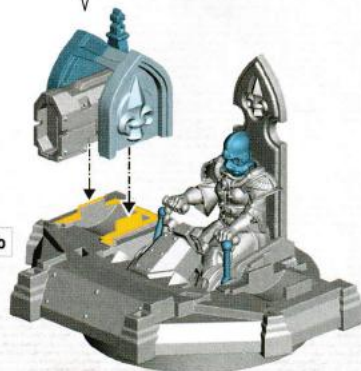

9 d

9 c

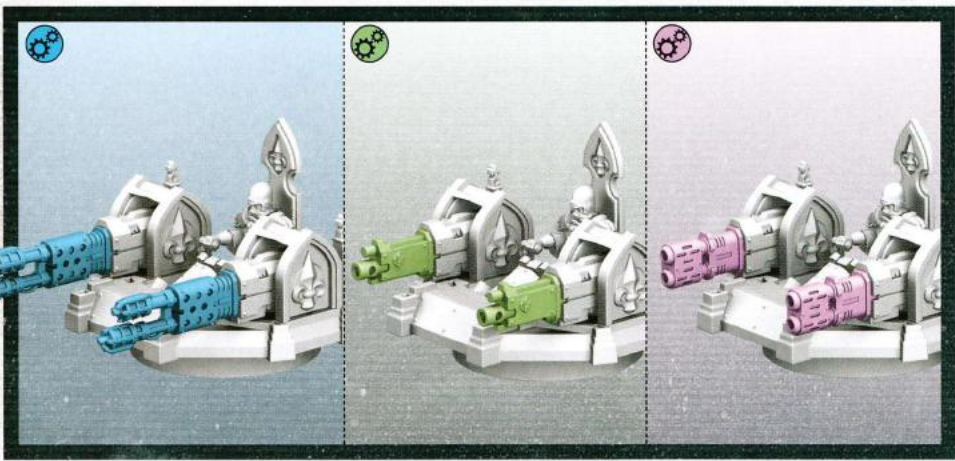
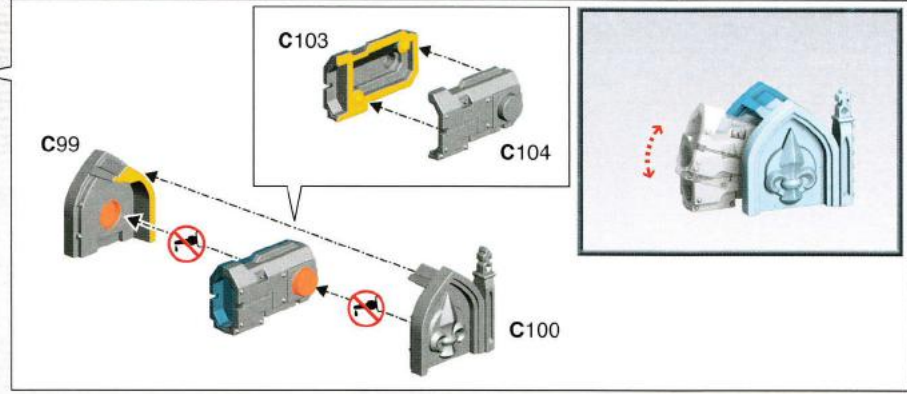
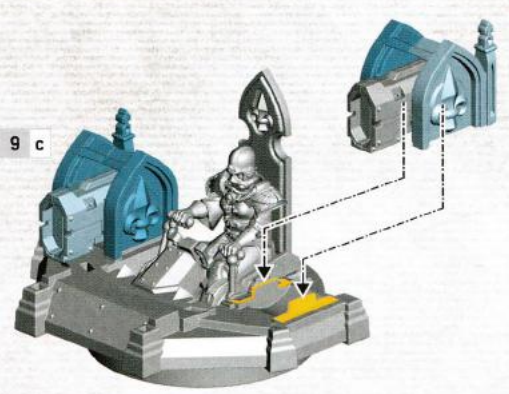

9 e

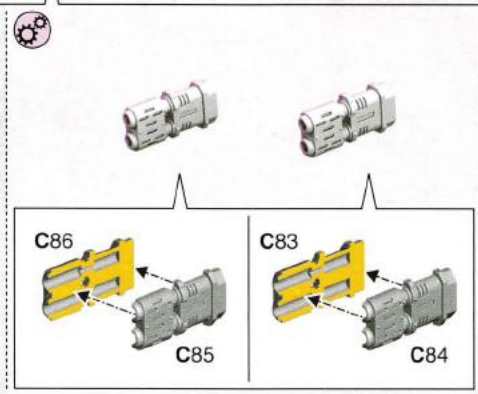
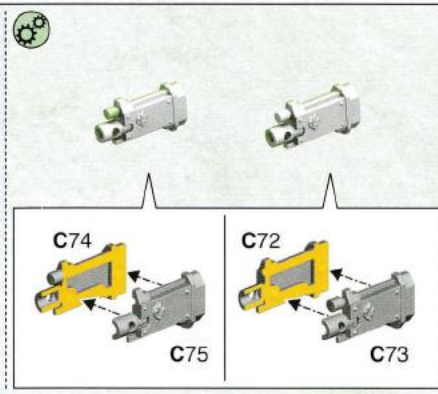
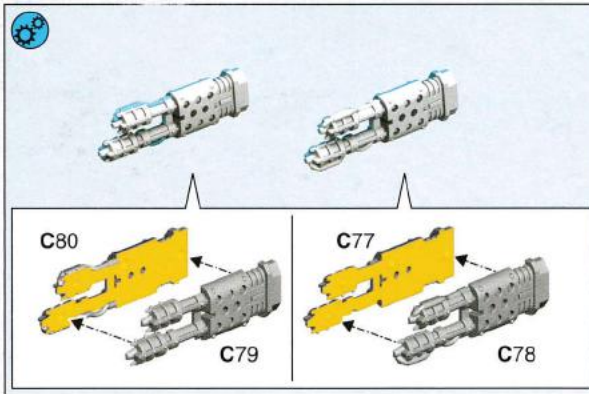
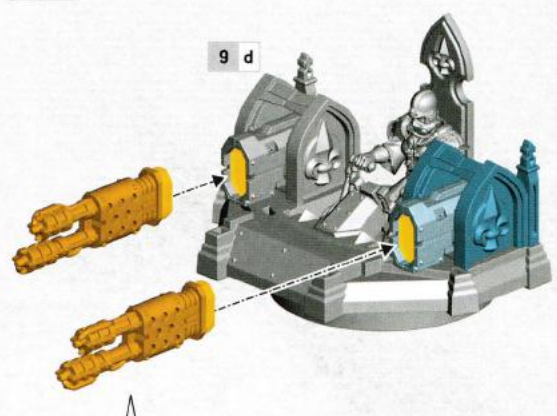

9 f

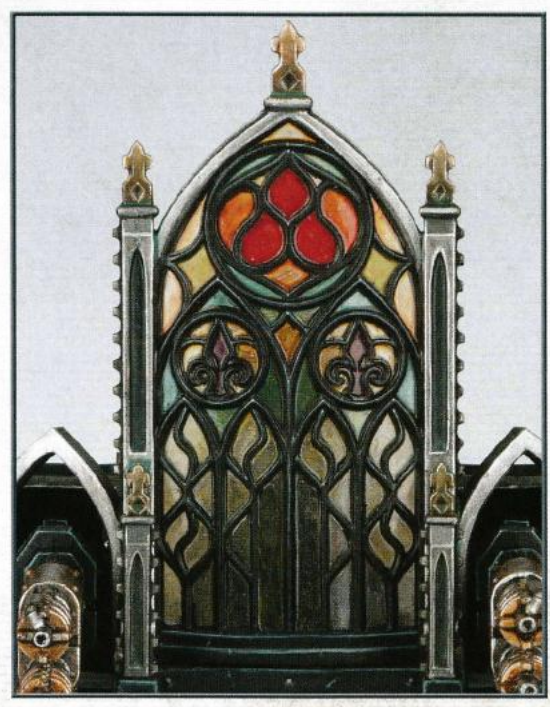
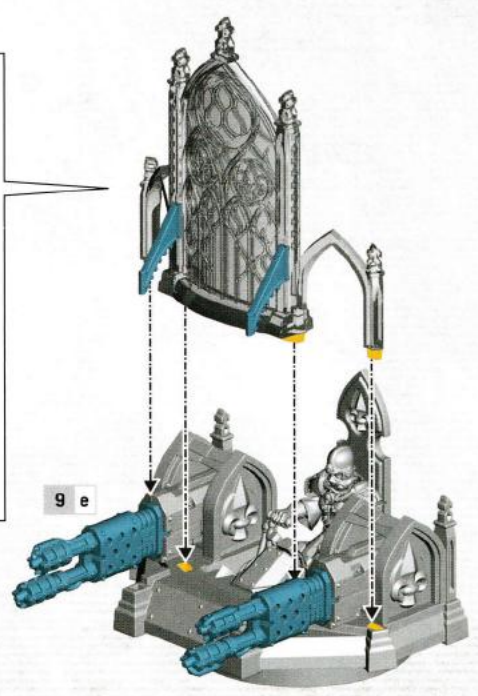
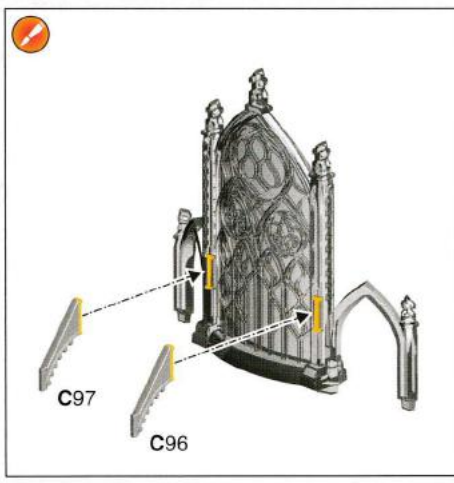

10 a

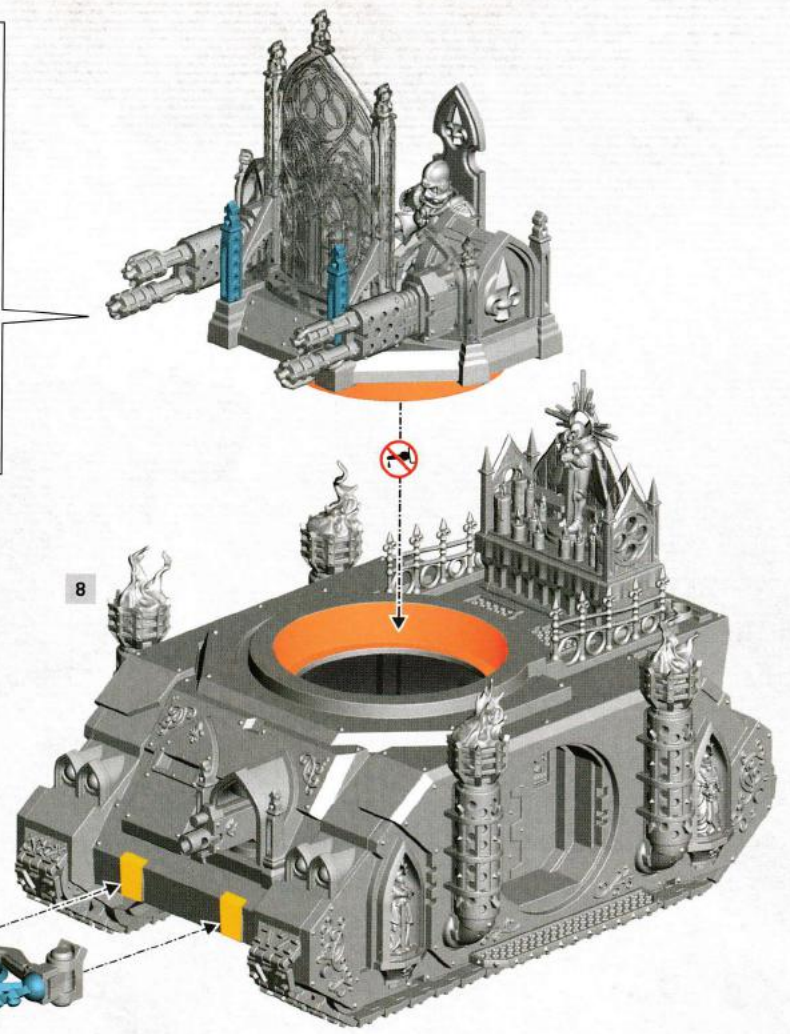
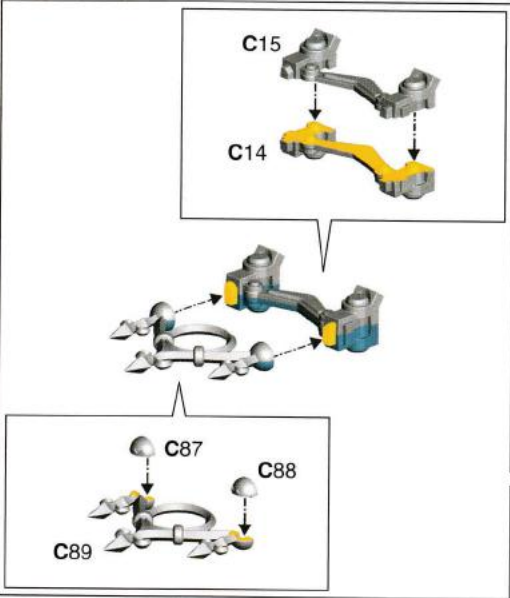
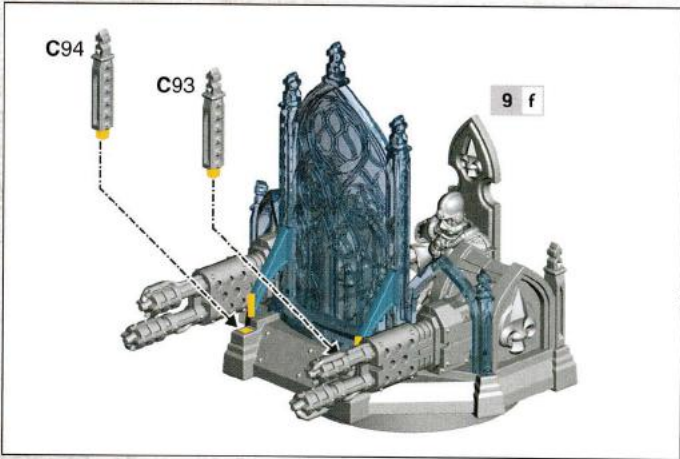

10 b

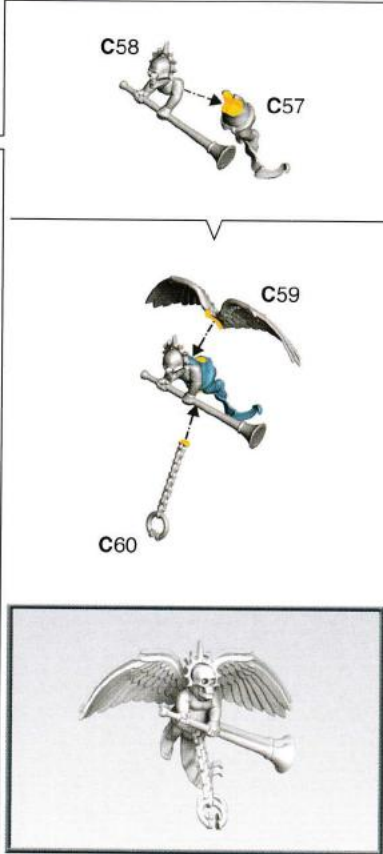
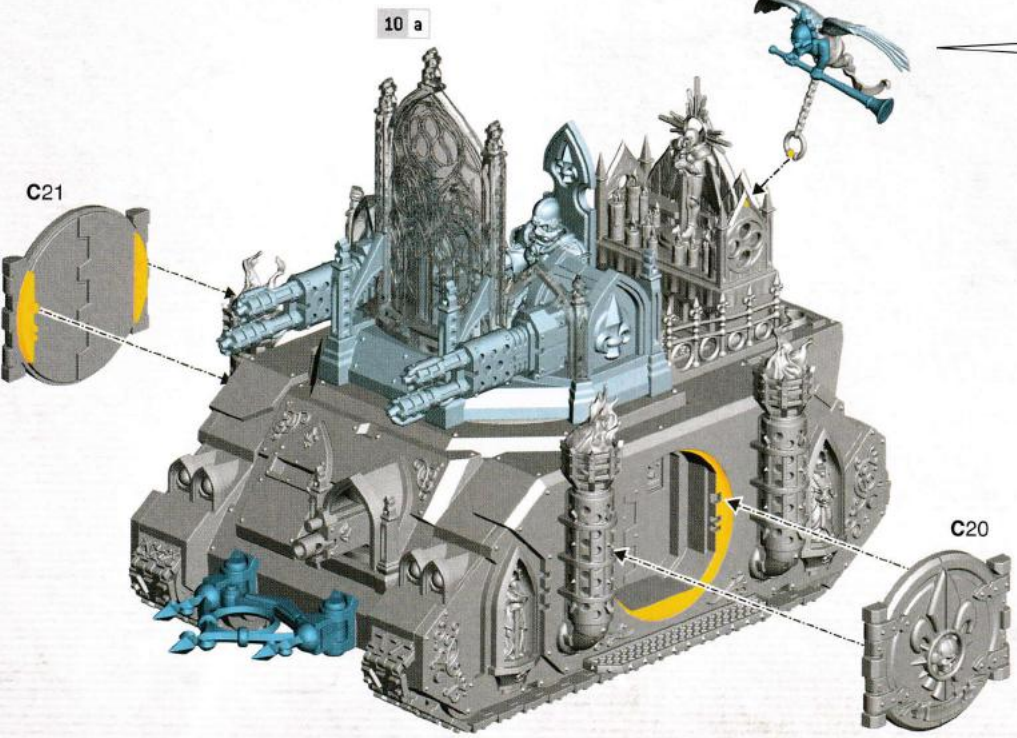

10 c

C34



C32



C31



C29

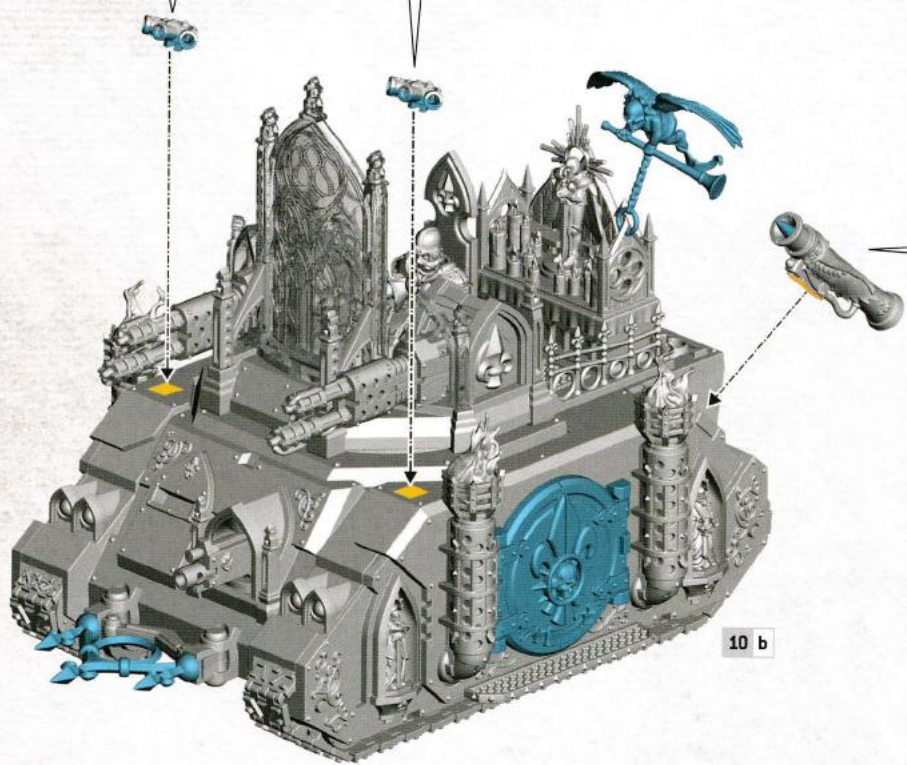

10 b

C28



C27

C26

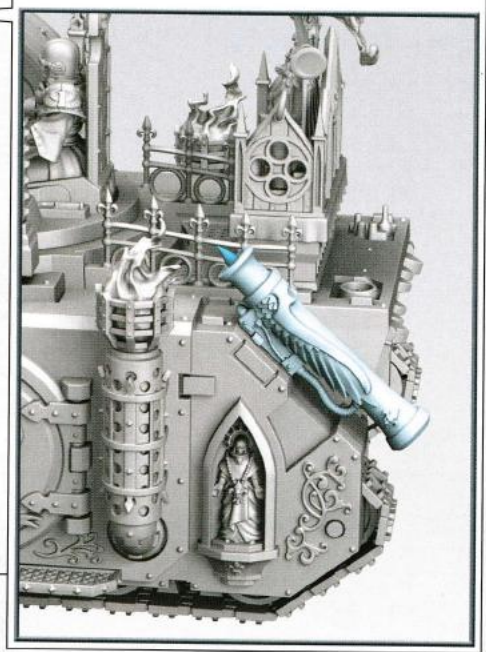

11 a

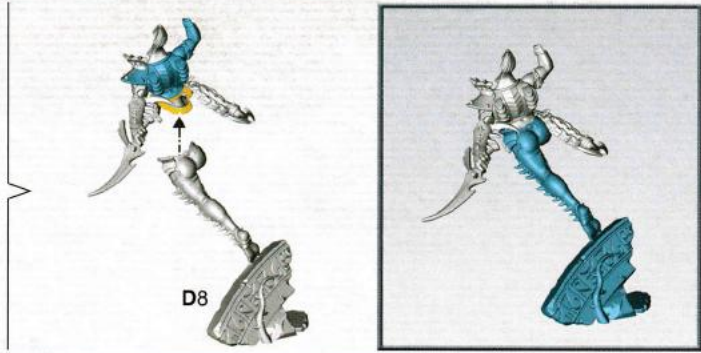
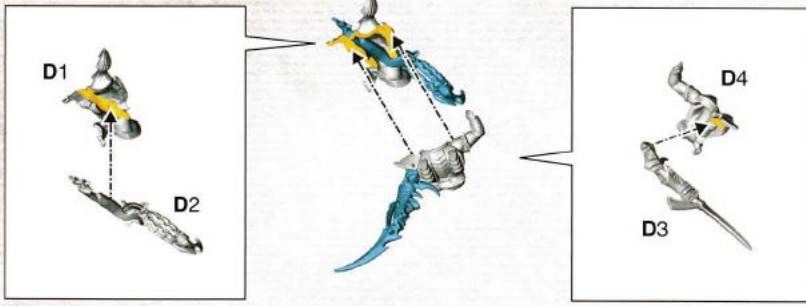

11 b

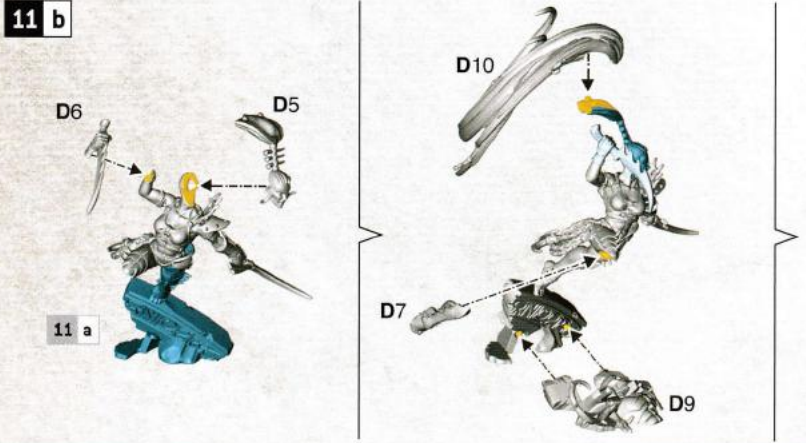

12 - 14 SCOURGES | スカージ | 天灾

12 a x5

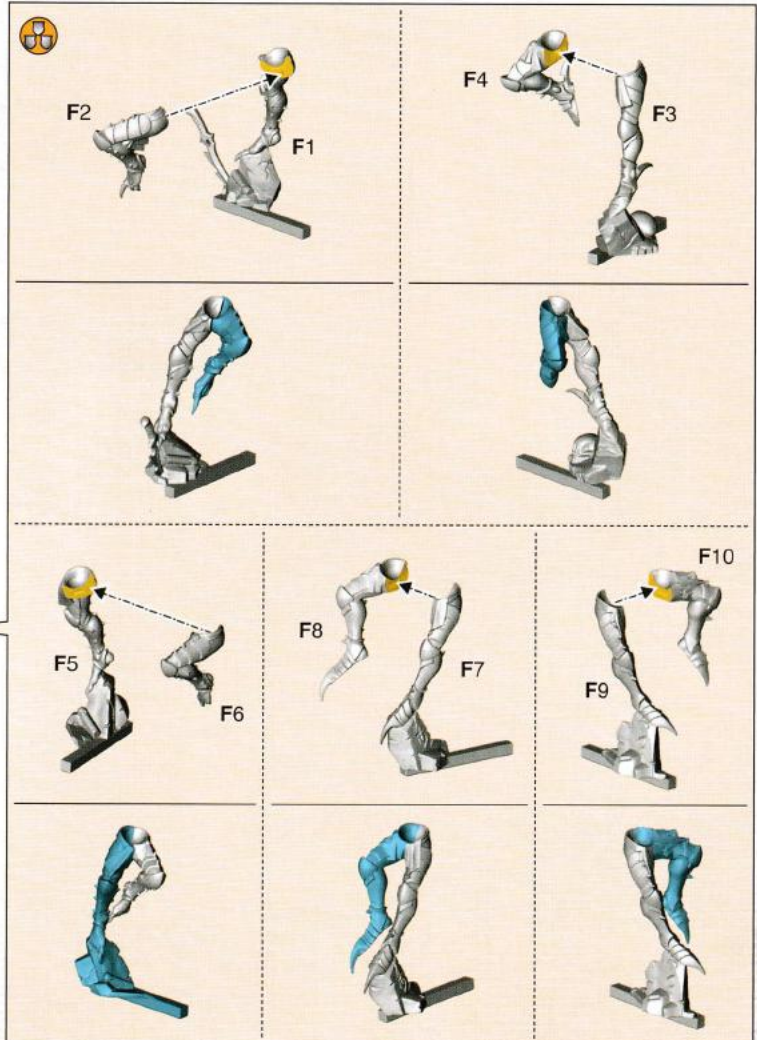
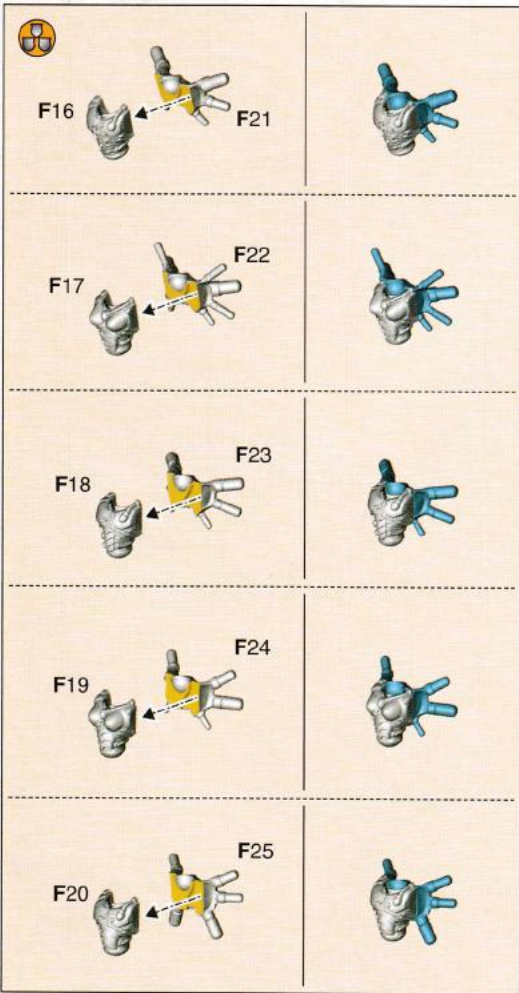

12 b x5

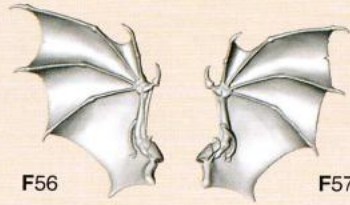
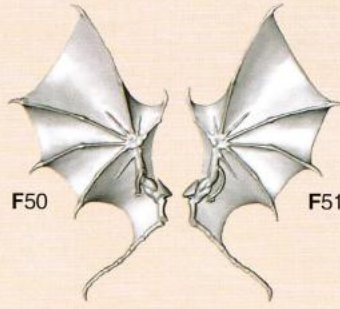

13 a Solarite | Solarite | Solarita | Solarith | Solarita | ソーラライト | 食日者

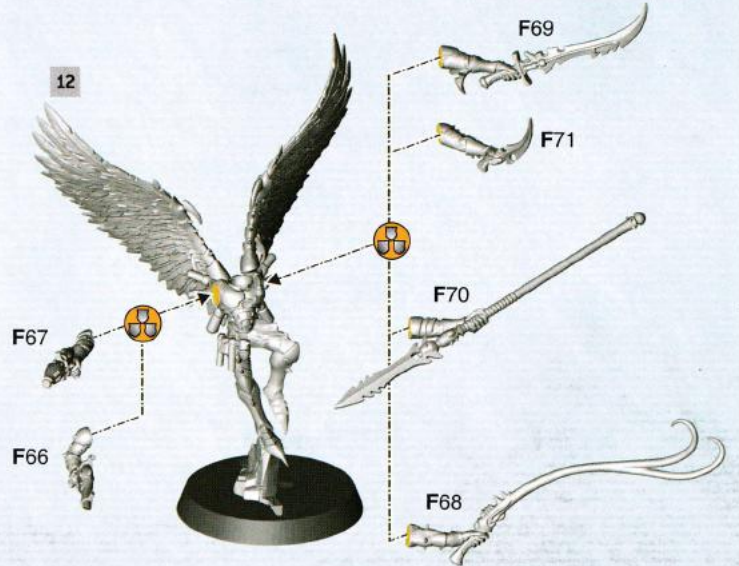



12



F33



F34

F37



F38

F60

F63



F35



F36

F39



F40

13 b

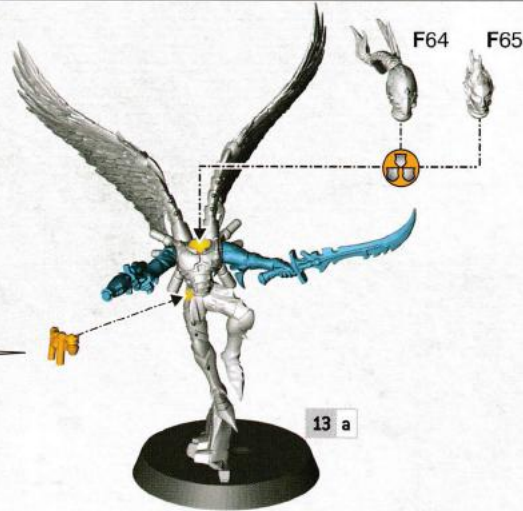
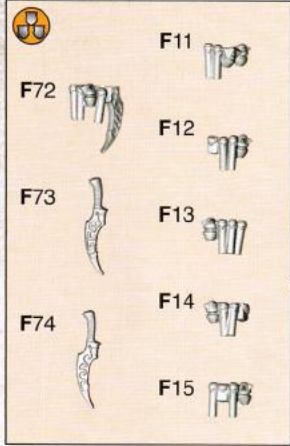

13 a

F64

F65

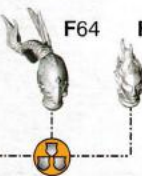

14 a Scourges | スカージ | 天災 x4



Scourge with shardcarbine
 • Scourge avec carbine éclatouse
 • Scourge con carabina cristalina
 • Scourge mit splitterkarabiner
 • Scourge con carabina a schegge
 • 装备碎片卡宾枪的天灾
 • スカージ (シャードカービン装備)



Scourge with blaster
 • Scourge avec disloqueur • Scourge con bláster
 • Scourge mit schattenkatapult
 • Scourge con fucile antimateria
 • 装备爆破枪的天灾 • スカージ (ブラスター装備)



Scourge with shredder
 • Scourge avec lacérateur • Scourge con desgarrador
 • Scourge mit shredder • Scourge con evisceratore
 • 装备粉碎者的天灾 • スカージ (シュレッダー装備)



Scourge with splinter cannon
 • Scourge avec canon éclateur
 • Scourge con cañón cristalino
 • Scourge mit splitterkanone
 • Scourge con cannone a schegge
 • 装备分裂加农炮的天灾
 • スカージ (スプリッターキャノン装備)



Scourge with haywire blaster
 • Scourge avec fusil disrupteur • Scourge con bláster de disrupción
 • Scourge mit impulseblaster
 • Scourge con fucile elettromagnetico
 • 装备干扰爆破枪的天灾 • スカージ (ヘイワイア・ブラスター装備)



Scourge with heat lance
 • Scourge avec lance de feu • Scourge con lanza incandescente
 • Scourge mit hitzelanze
 • Scourge con lancia termica
 • 装备高热长枪的天灾 • スカージ (ヒートランス装備)



Scourge with dark lance
 • Scourge avec lance de ténèbres • Scourge con lanza oscura
 • Scourge mit schattenlanze
 • Scourge con lancia oscura
 • 装备黑暗长枪的天灾 • スカージ (ダークランス装備)

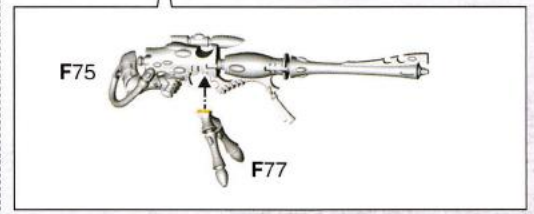
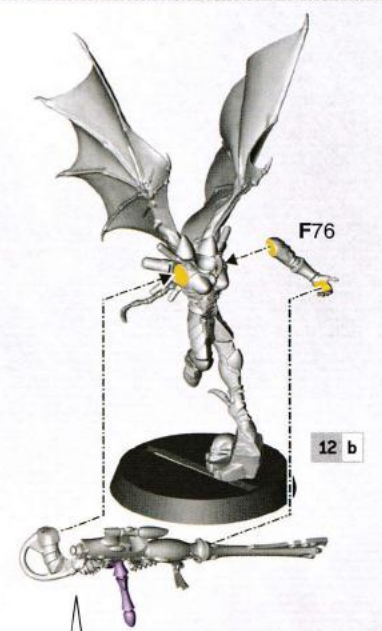
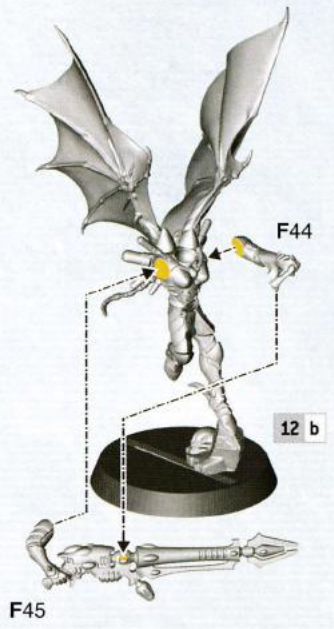
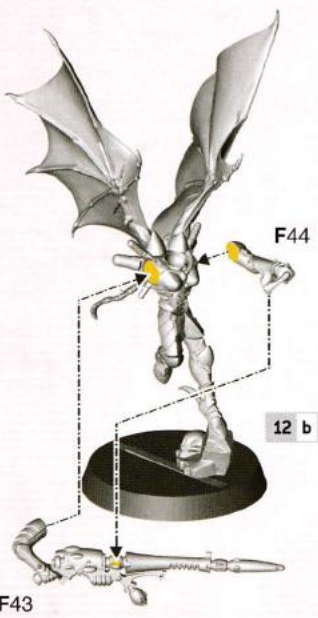
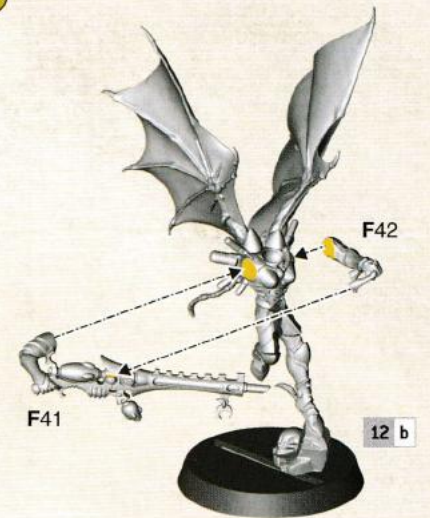
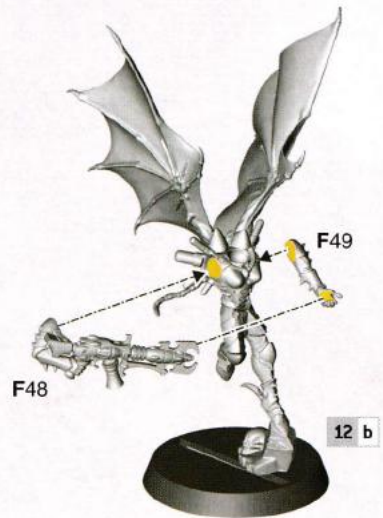
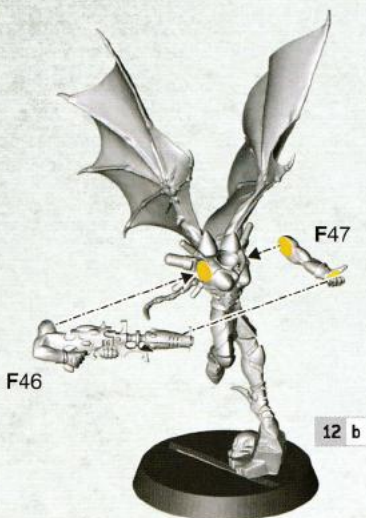
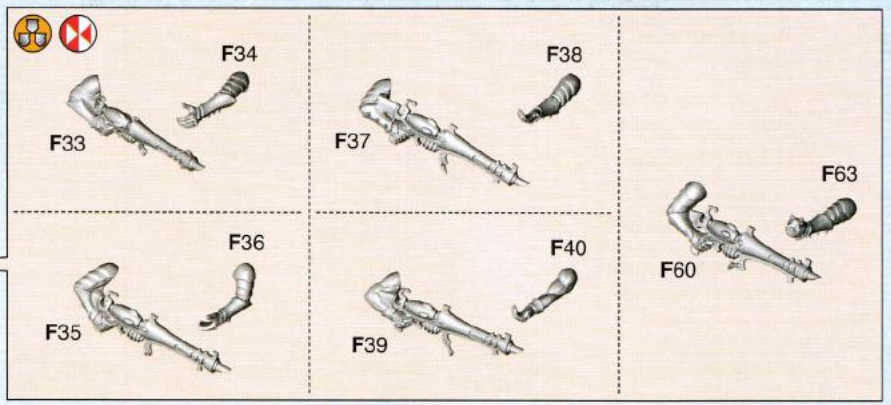

14 b x4

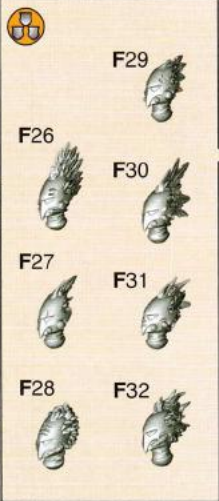

14 a

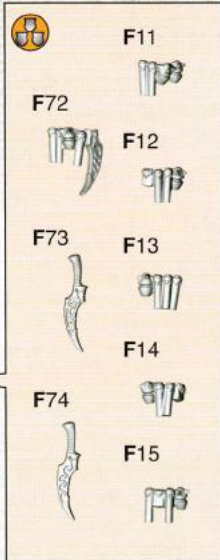

15 - 19 WYCHES | CÉRASTES | BRUJAS | HEKATARI | ERYNNI | ウィッチ | 巫灵

15 Hekatrix | Céreste avec épées-fouets | Bruja con flagelos encadenados | Hekatori mit Klängenpeitschen | Erynni con flagelli uncinati | ウィッチ (レイザーフレイル装備) | 装备剃刀连枷的巫灵

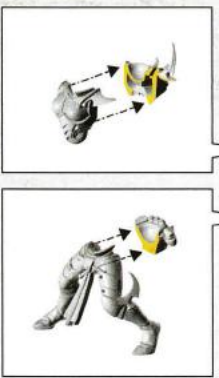

16 Wych with hydra gauntlets | Céreste avec gantelets-hydes | Bruja con brazales hidra | Hekatori mit Hydrhandschuhen | Erynni con guanti dell'Idra | ウィッチ (ヒドラ・ガントレット装備) | 装备九头蛇臂铠的巫灵

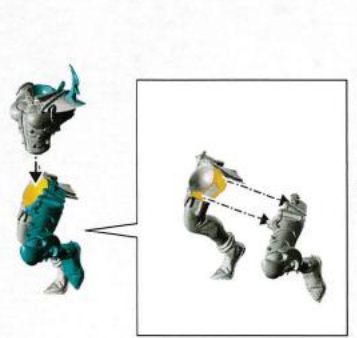
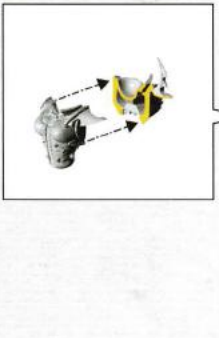

17 Wych with shardnet and impaler | Céreste avec filet barbelé et empaleur | Bruja con filorred y empalador | Hekatori mit Dornennetz und Pfähler | Erynni con rete dilaniante e forca impalatrice | ウィッチ (シャードネット、インペイラー装備) | 装备碎片网和穿刺者的巫灵

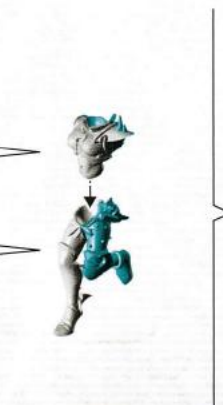
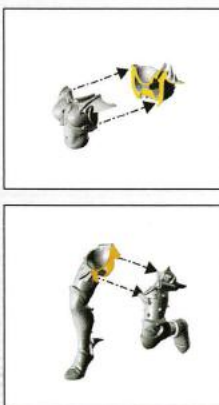

18 Wych with razorflails | Céreste avec épées-fouets | Bruja con flagelos encadenados | Hekadari mit Klängenpeitschen | Erynni con flagelli uncinati | ウィッチ (レーザーフレイル装備) | 装备剃刀连枷的巫灵



19 Wyches | Cérestes | Brujas | Hekatarii | Erynni | ウィッチ | 巫灵

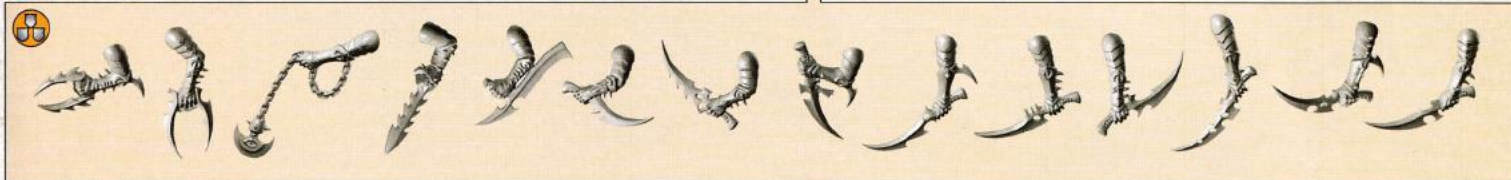

20 - 23 VENOM | ヴェノム | 毒药战机

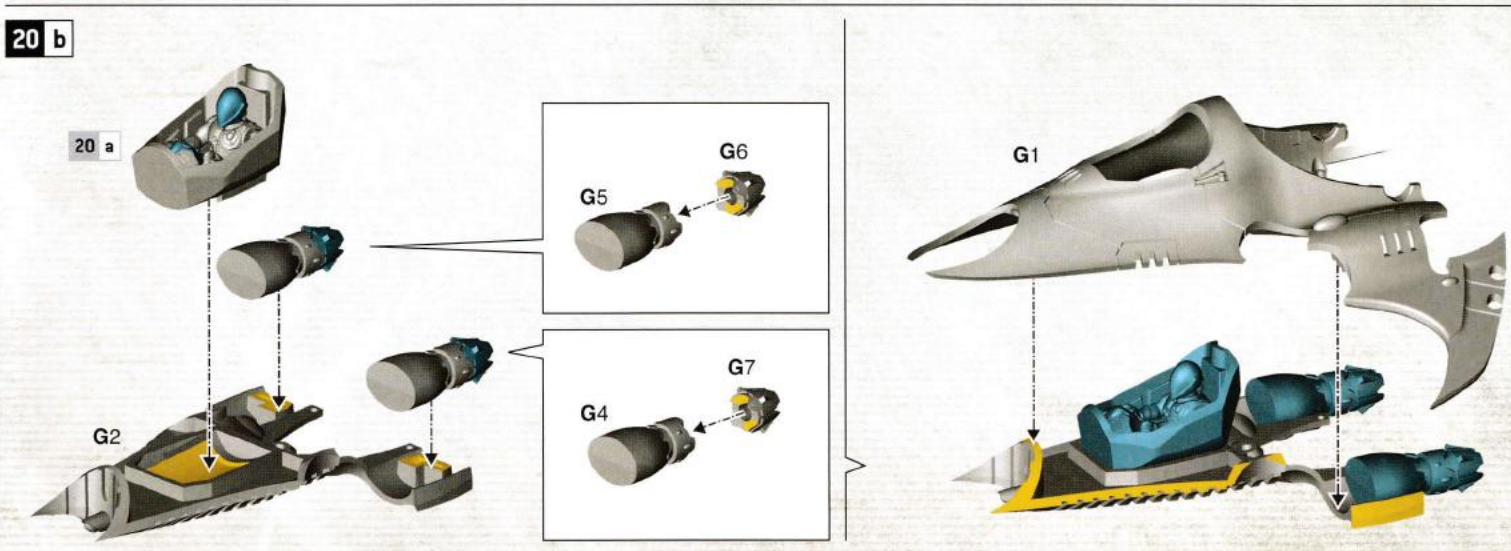
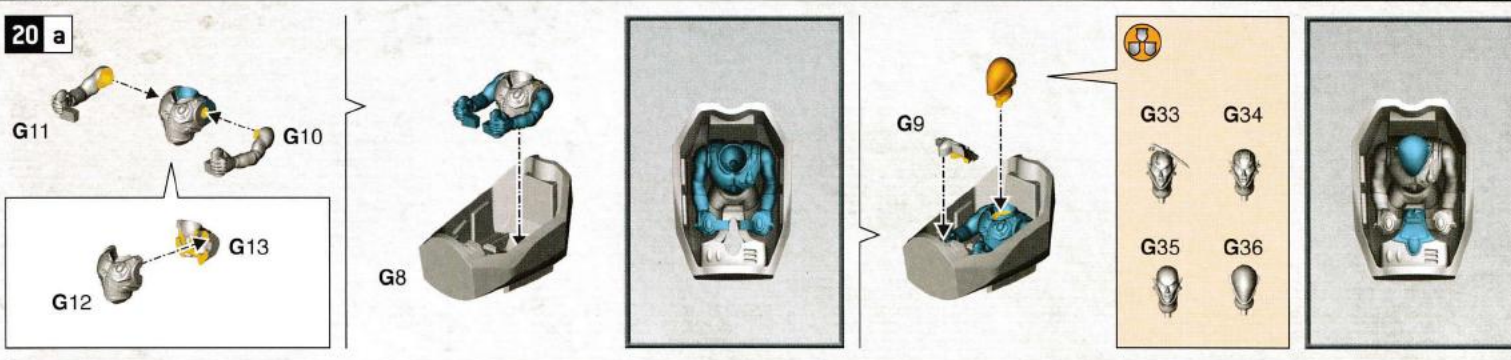

20 c

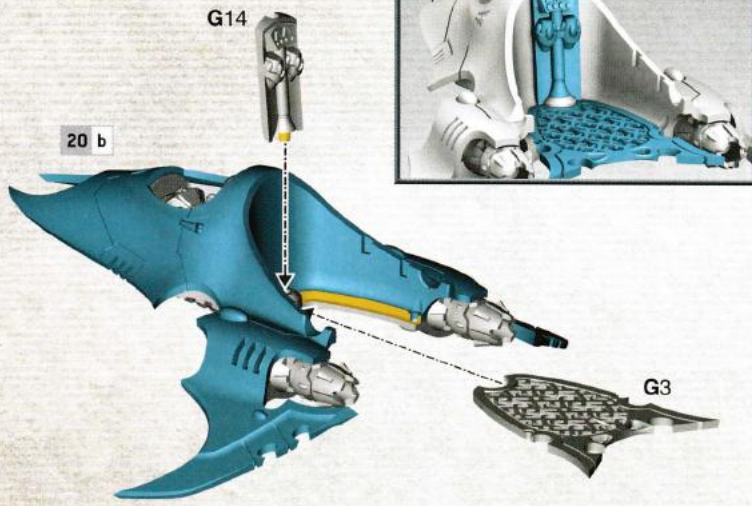

20 d

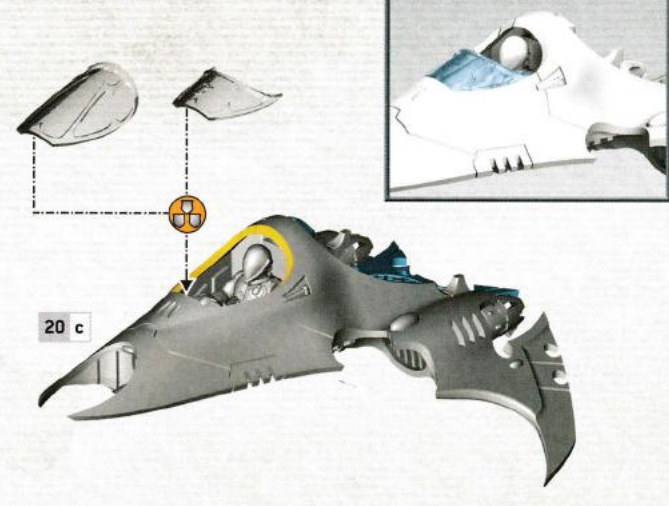

20 e

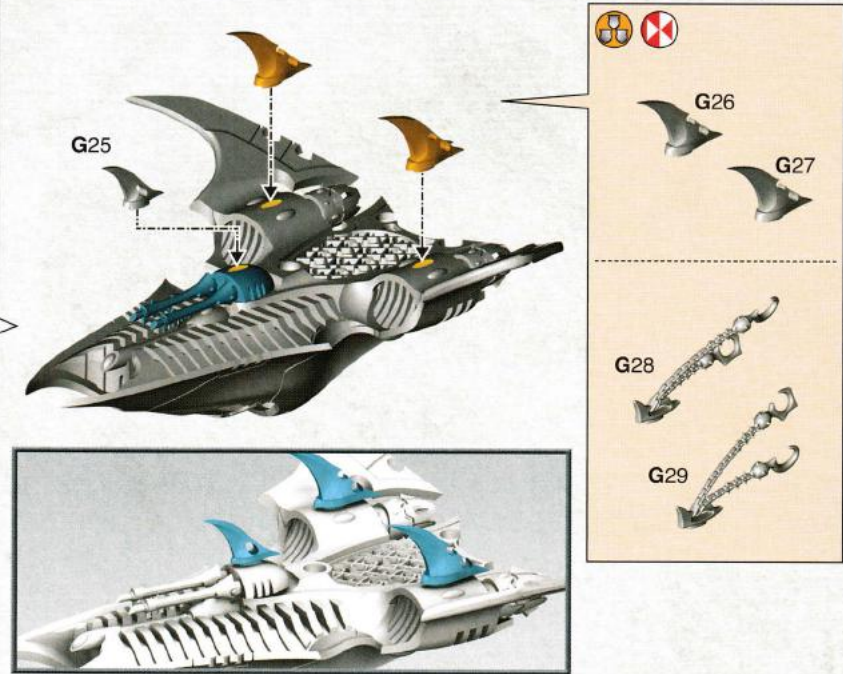
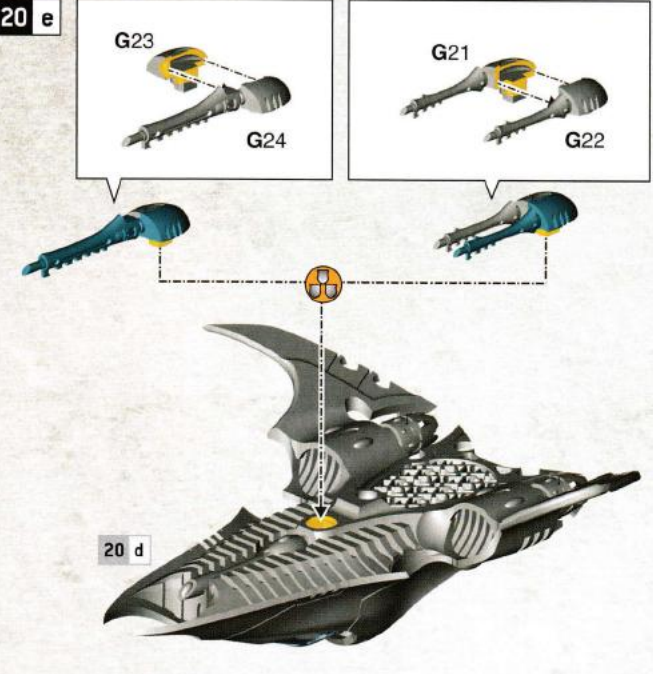

20 f

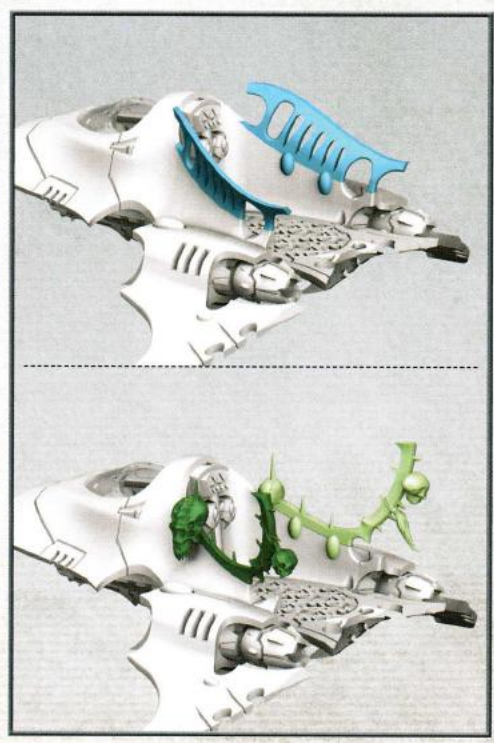
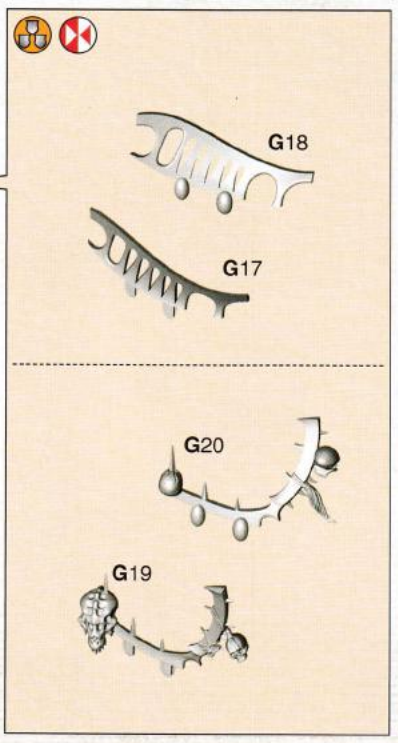
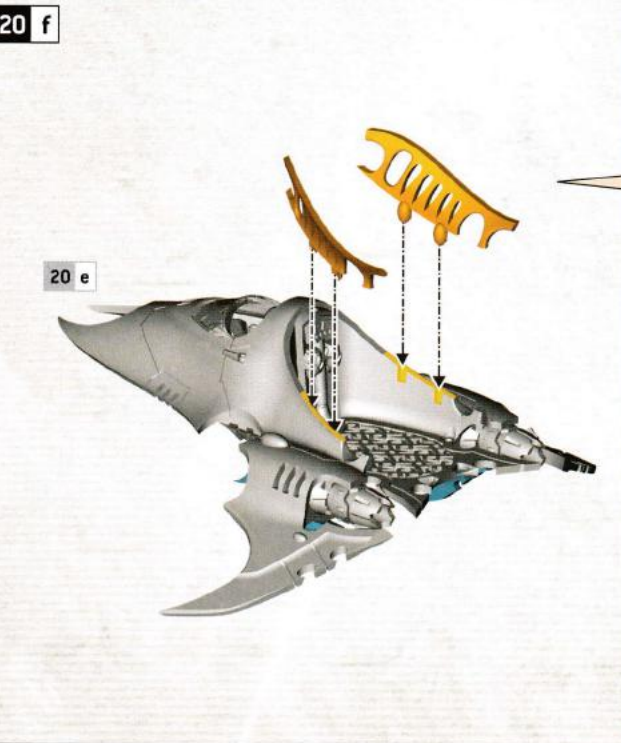

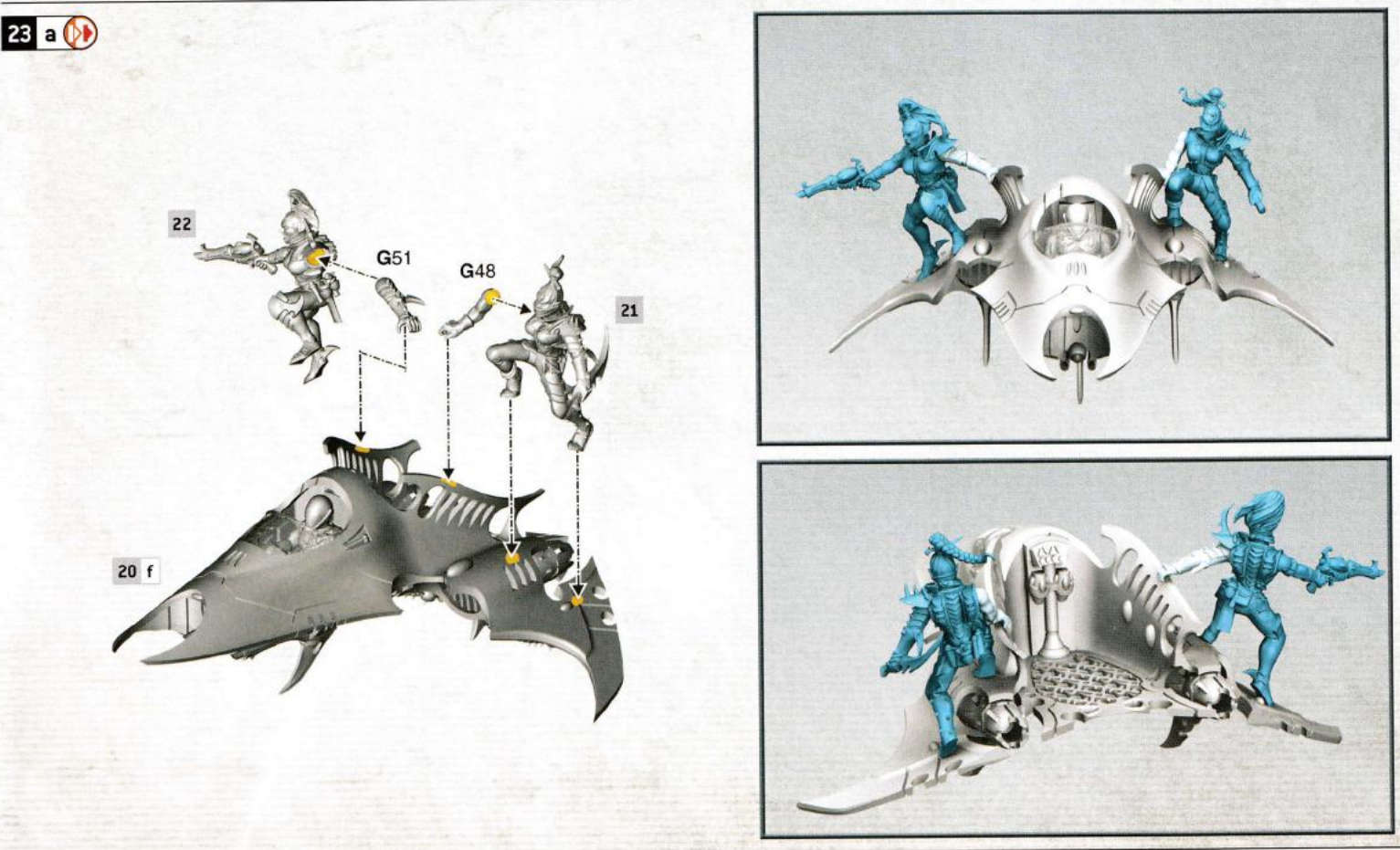
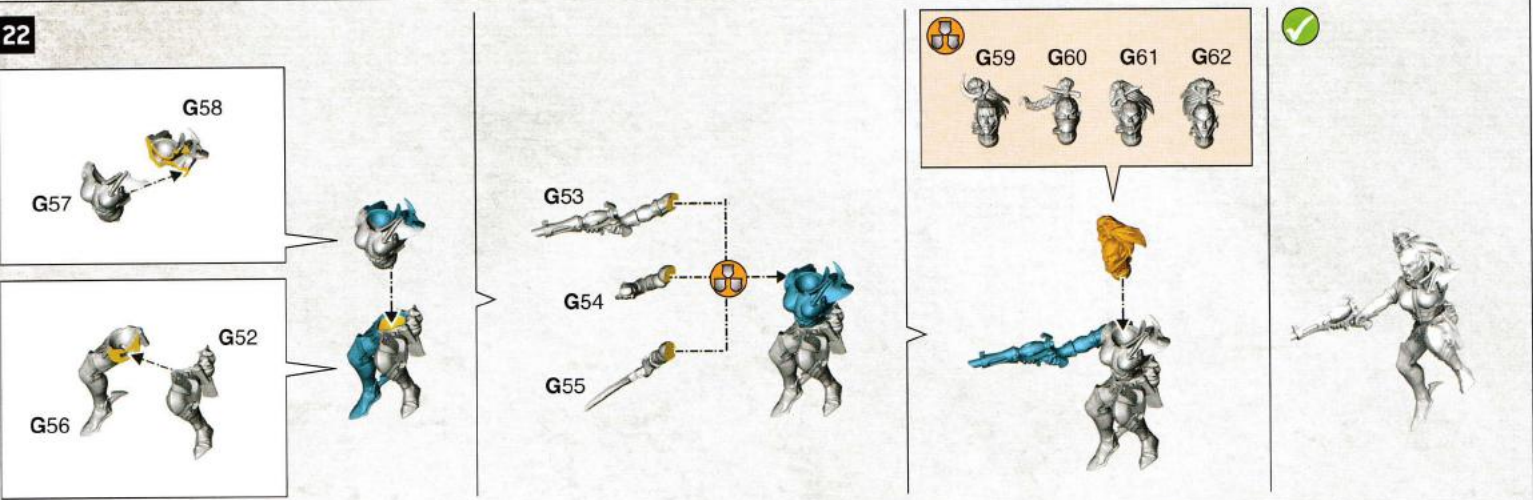
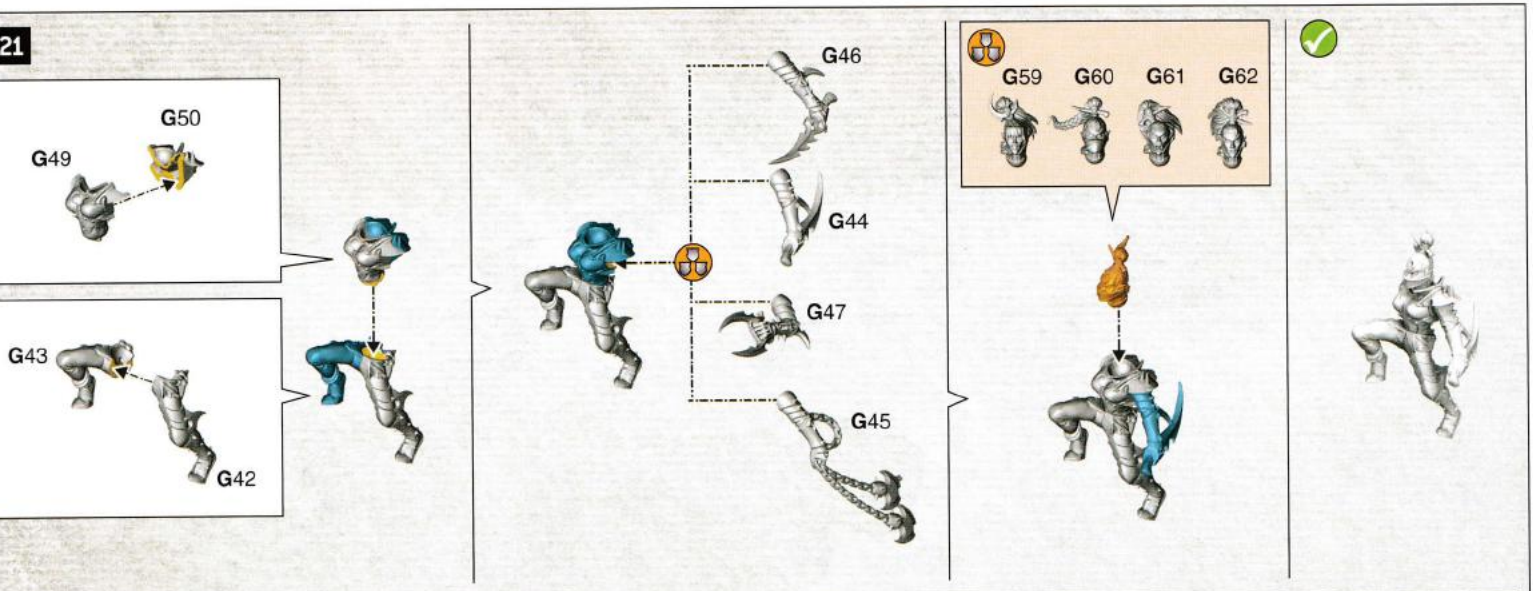

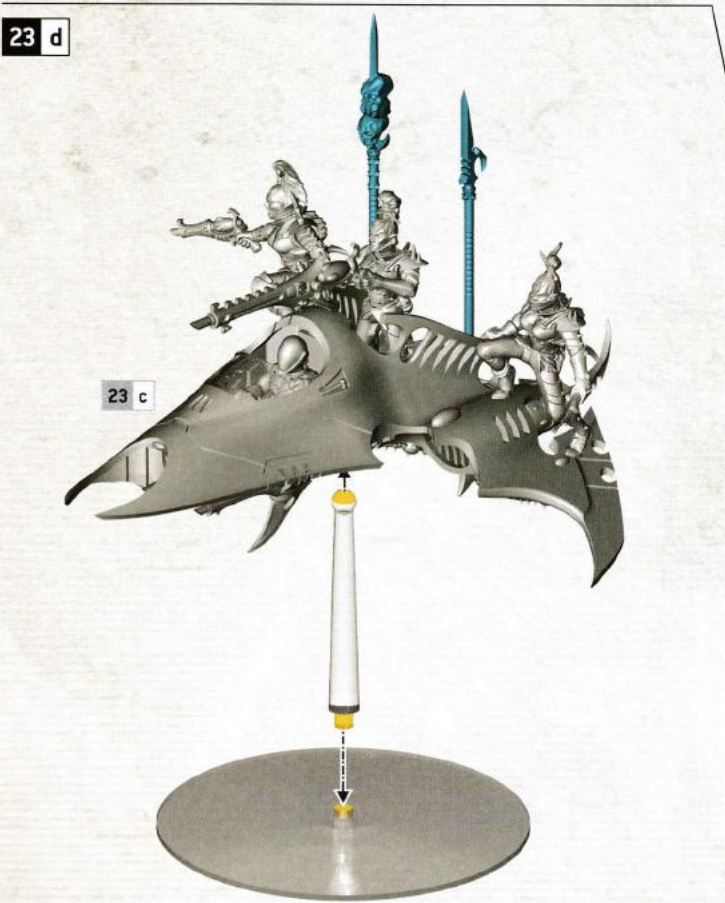
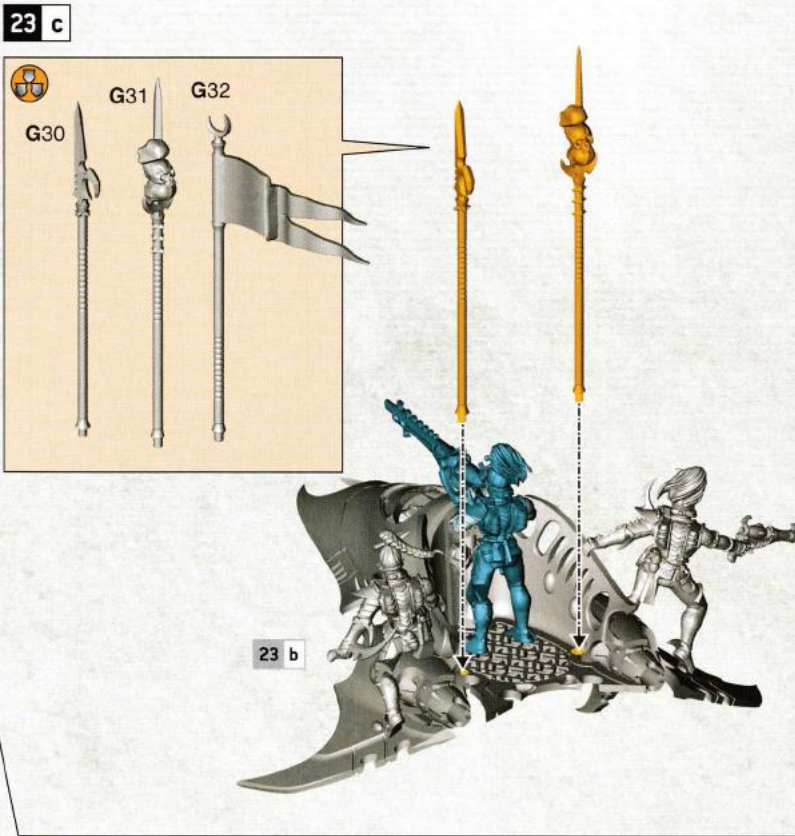
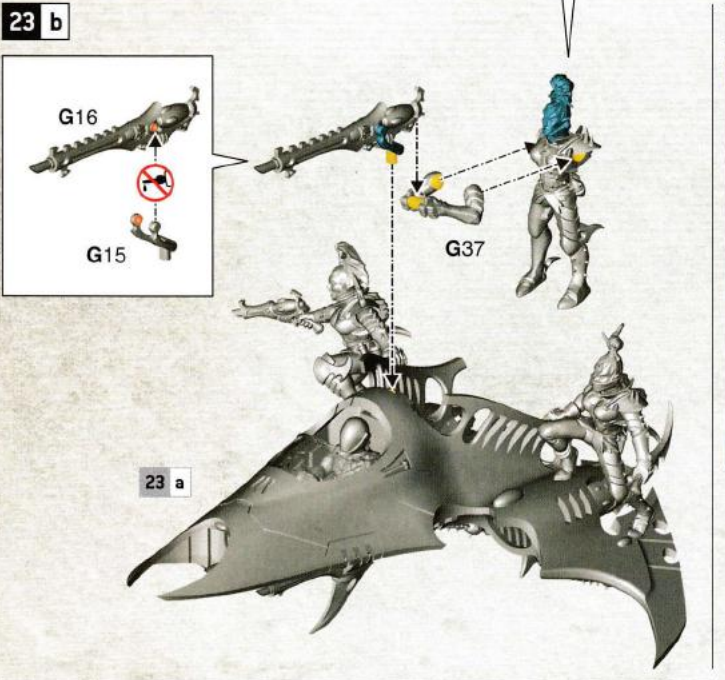
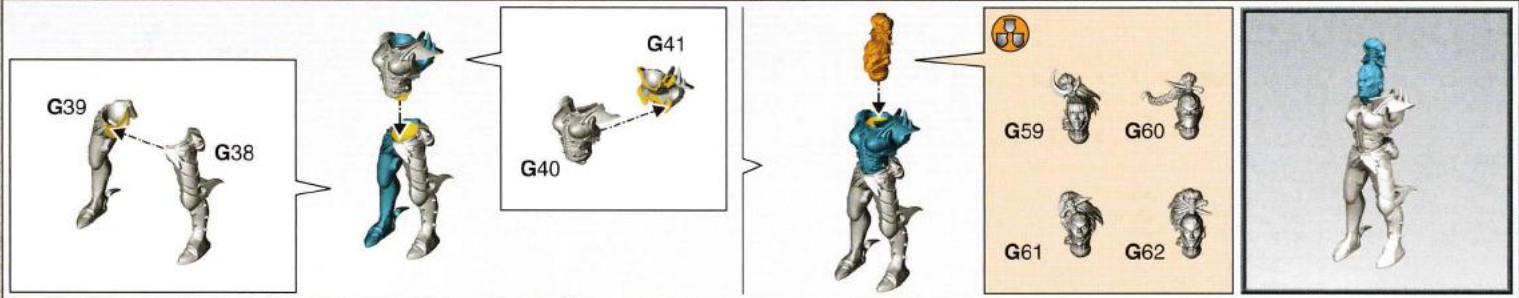

warhammer.com
 Games Workshop Limited, Willow Road, Nottingham, NG7 2WS, UK
 © Copyright Games Workshop Limited 2021.

