



Free Downloads of Build Instructions,
Assembly Booklets & How To Guides

BuildInstructions.com

KX139 TA'UNAR SUPREMACY ARMOUR FUSION ERADICATOR

Designed as a radical solution to the limitations of current Tau fusion weapons technology, the Fusion Eradicator is a composite weapon which creates a blast of energy so potent that solid matter caught in its path is torn apart at a molecular level by brute thermal force, and no physical material yet known to the Tau can survive its destructive power. The cost in materials and expertise to create a single Fusion Eradicator however is immense, and the natural endurance of each is limited often to a single battle, meaning the weapon is employed only by the most elite units and in the direst of conflicts.

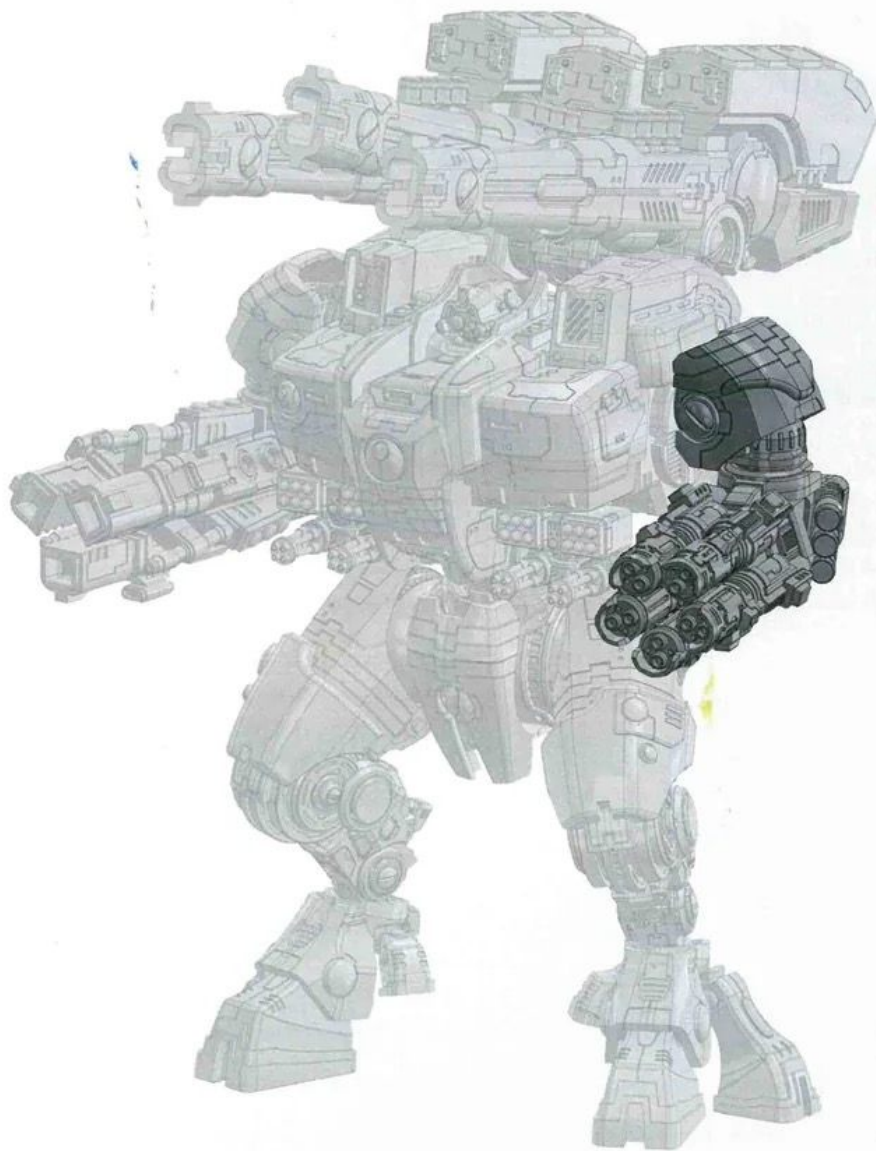

THIS IS NOT A TOY

Not suitable for children under 15 years of age.

WARNING: Resin dust can be harmful if inhaled. Always wear a dust mask or respirator when sanding or sawing resin parts.

forgeworld.co.uk



993201130044



Components

Before assembly, check that none of the components are missing.

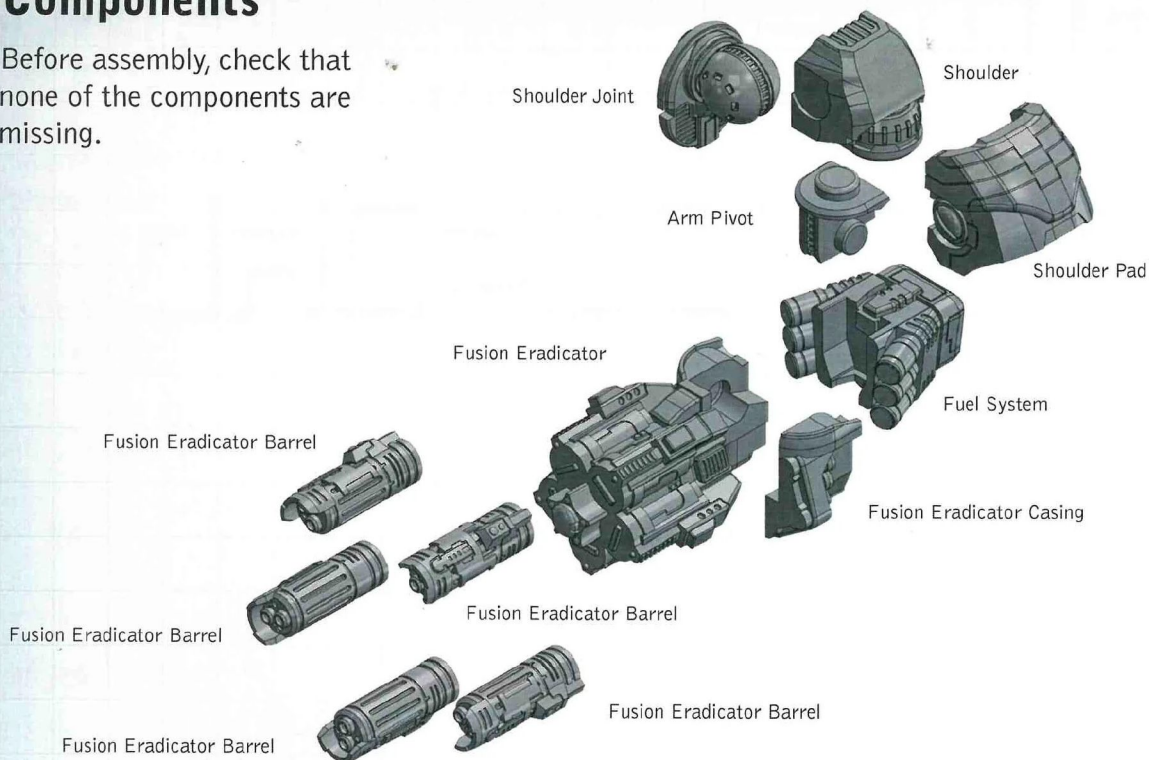

Assembly Legend

Parts for Assembly



Note



Insert

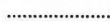

Reverse Angle



Assembly Options



Glue Contact Area



Component Highlight



Preparing the Model for Assembly

Before assembling the model, wash each part thoroughly with an abrasive brush, such as a toothbrush, to remove any model release agent that may still be on the surface of the parts. Then, remove any excess resin such as mould lines, casting gates, vents and shims. For a more detailed guide to working with resin models, go to the Downloads section of the Forge World website.

This kit contains all the pieces required to construct a KX139 Ta'unar Supremacy Armour Fusion Eradicator. To glue the resin pieces together, use Citadel Super Glue.

NOTE: We have cast this kit using advanced techniques and high quality resin, but due to the nature of the casting process, your model may contain small air bubbles. These can easily be filled with model filler or super glue. Any slight warpage of thin parts can easily be corrected by immersing the part in hot tap water for about 1 minute, then carefully bending it back into shape.

If you need to contact the Forge World Customer Service team regarding this model, you can get in touch via email - forgeworld@gwplc.com - or call:

0115 900 4995 within the UK

011 44 115 900 4995 from the USA and Canada

0011 44 115 900 4995 from Australia

011 44 115 900 4995 from Europe and the rest of the world.

1

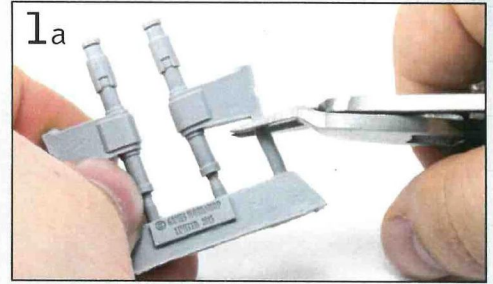
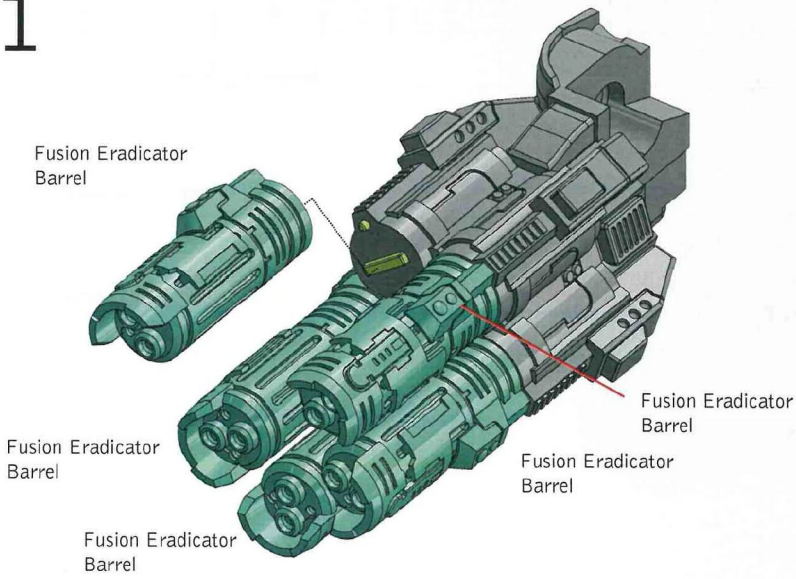

Use a pair of clippers to remove any vents and casting gates. The Working with Resin guide on the Forge World website goes into more detail about cleaning up resin components.

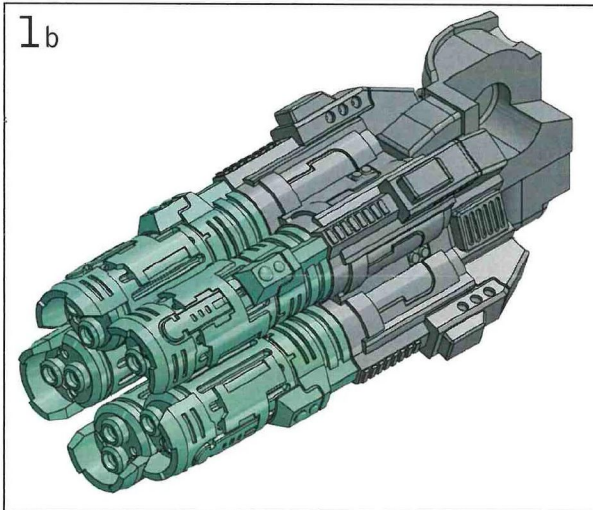

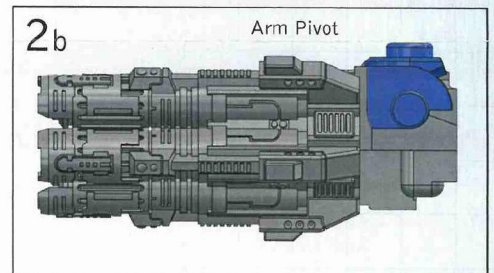
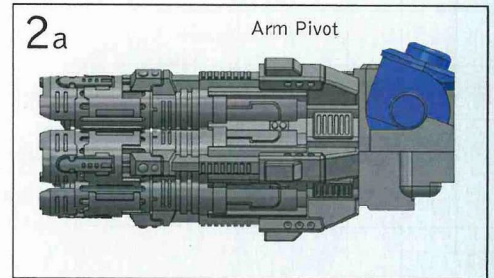

2

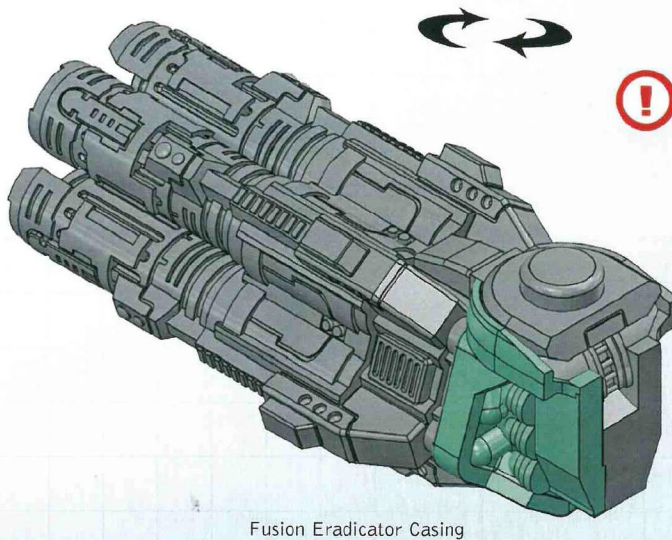

 The Arm Pivot can be angled depending on how you want the arm to be positioned.

3



 Once the Arm Pivot is secured in position, attach the Fusion Eradicator Casing over it as shown in Diagram 3.

Fusion Eradicator Casing

4

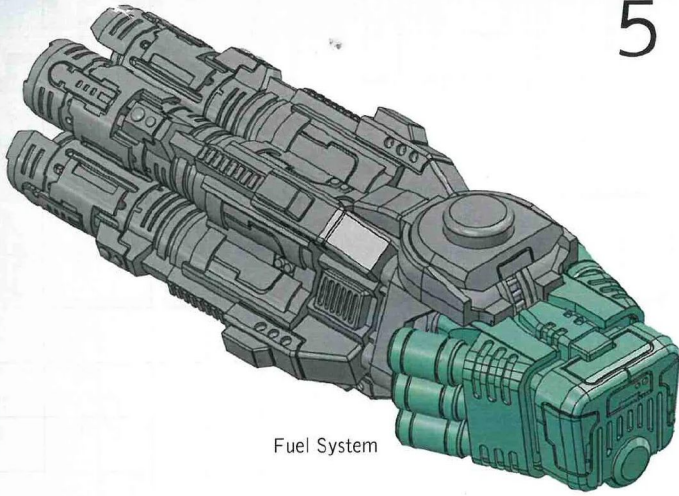

Fuel System

5

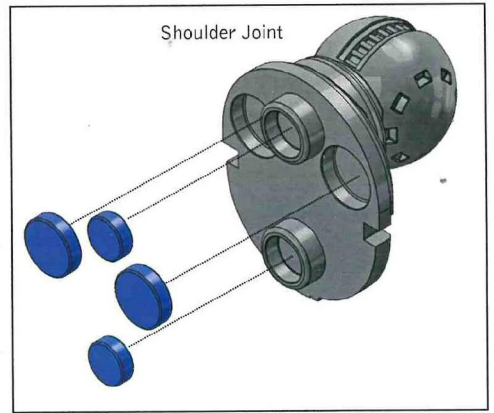

Shoulder Joint

Recessed areas in the Shoulder Joint can be used to mount magnets (6x2mm and 8x2mm in size), allowing each arm to be removed. Magnets are not supplied with this model kit.

6

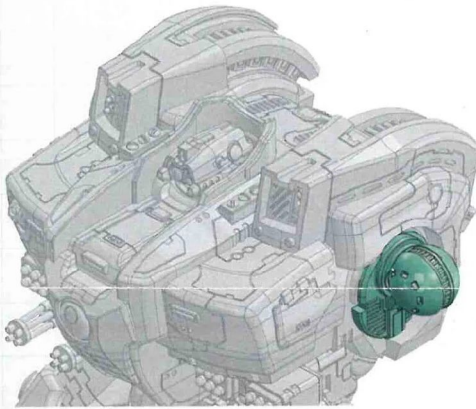

Shoulder Joint

7

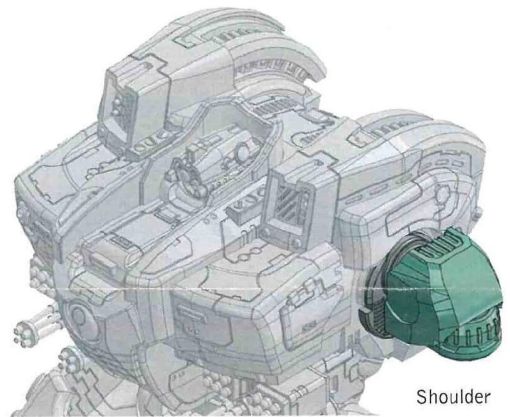

Shoulder



The Fusion Eradicator can be mounted to either the left or right side of the KX139 Ta'unar Supremacy Armour.

8

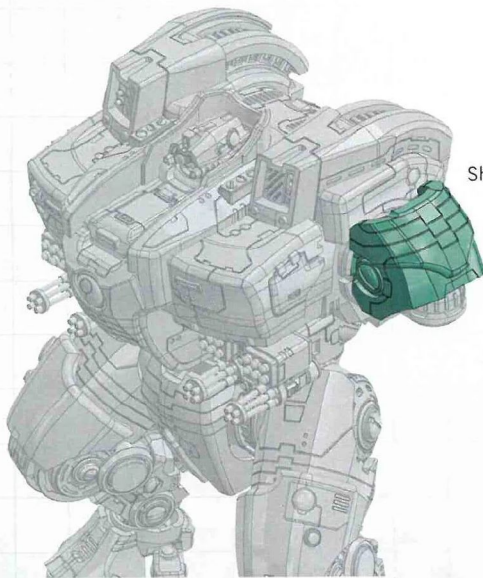

Shoulder Pad

9

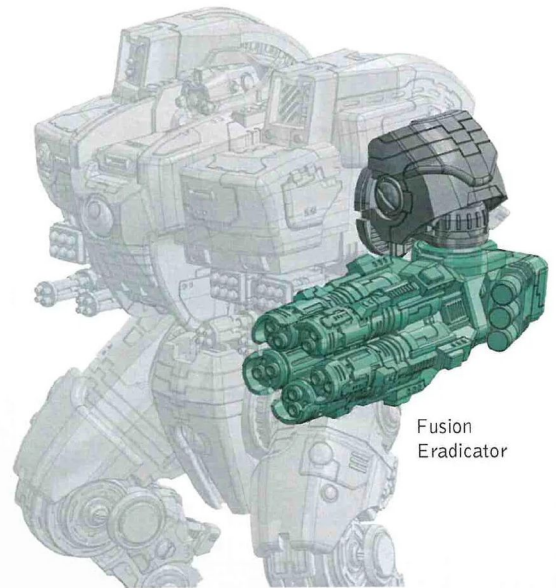

Fusion Eradicator