



Free Downloads of Build Instructions,
Assembly Booklets & How To Guides

BuildInstructions.com

WARHAMMER
40,000

COMBAT PATROL



T'AU EMPIRE

PATROUILLE | PATRULLA DE COMBATE | KAMPFPATROUILLE
PATTUGLIA DA COMBATTIMENTO | コンバットパトロール | 战斗巡逻队

ENG BEFORE ASSEMBLING YOUR MINIATURES, PLEASE READ THROUGH THE INSTRUCTIONS IN THIS BOOKLET CAREFULLY. A pair of plastic cutters is required to remove the plastic components in this kit from their frame. We advise using a mouldline scraping tool to clean up the parts. To assemble your model you will need plastic glue. Games Workshop sells Citadel Fine Detail Cutters, Citadel Mouldline Remover and Citadel Plastic Glue, but does not recommend these products for use by children under the age of 16 without adult supervision.

FRE AVANT D'ASSEMBLER VOS FIGURINES, VEUILLEZ LIRE ATTENTIVEMENT LES INSTRUCTIONS DE CE LIVRET. Une pince coupante est requise pour détacher chaque élément de sa grappe. Nous vous recommandons l'utilisation d'un grattoir pour ébarber les éléments. Pour l'assemblage, vous aurez également besoin de colle plastique. Games Workshop commercialise les Pinces de Précision Citadel, l'Ébarboir Citadel et la Colle Plastique Citadel, mais n'en recommande pas l'utilisation pour des enfants de moins de 16 ans sans la supervision d'un adulte.

SPA POR FAVOR, LEE CUIDADOSAMENTE ESTE LIBRETO DE INSTRUCCIONES ANTES DE EMPEZAR A MONTAR LAS MINIATURAS. Te harán falta unas tenazas para plástico a fin de separar las piezas de la matriz. También aconsejamos una herramienta para rebabas a fin de limpiar cada pieza. Para montar la miniatura necesitarás pegamento para plástico. Games Workshop vende Tenazas Citadel, Herramientas para rebabas Citadel y Pegamento para plástico Citadel, pero no recomienda estos productos a menores de 16 años sin la supervisión de un adulto.









GER VOR DEM ZUSAMMENBAU DER MINIATUREN BITTE DIE ANWEISUNGEN IN DIESER ANLEITUNG AUFMERKSAM DURCHLESEN. Du benötigst einen Kunststoffseitenschneider, um die Kunststoffbauteile aus dem Gussrahmen herauszutrennen, und Kunststoffkleber, um die Miniatur zusammenzubauen. Außerdem empfehlen wir, die Bauteile vorher mit einem Gussgratentferner zu säubern. Games Workshop bietet Präzisions-Kunststoffseitenschneider von Citadel sowie Citadel-Kunststoffkleber an, empfiehlt aber, dass Kinder unter 16 Jahren diese nur unter Aufsicht eines Erwachsenen benutzen.

ITA PRIMA DI ASSEMBLARE LE TUE MINIATURE LEGGI ATTENTAMENTE TUTTE LE ISTRUZIONI DI QUESTO LIBRETTO. Sono necessarie un paio di tronchesine per plastica per staccare i componenti dai loro sprue. Consigliamo di usare un attrezzo apposito per pulire i componenti. Per assemblare il modello avrai bisogno di colla per plastica. Games Workshop vende Tronchesine di precisione Citadel, Attrezzo per ripulire Citadel e Colla per plastica Citadel, ma non consiglia questi prodotti ad un pubblico minore di 16 anni senza la supervisione di un adulto.

日語 ミニチュアを組み立てる前に、この冊子の説明をよくお読みください。本キット内のフレームからプラスチックパーツを切り離すためには、ニッパーが必要です。パーツのモールドを平らにするには、専用ツールを使用をお勧めいたします。本キットの組み立てには、プラ用接着剤が必要です。ゲームズワークショップはシタデル・ニッパー、プラ用接着剤、シタデル・モールドラインリムーバーを販売しておりますが、16歳以下の子供が大人の監督なしにこれらの道具を使用されることをお勧めしません。

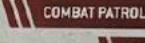
中文 组装模型前请仔细阅读本手册中的说明。你需要一把模型剪将塑料部件从板件上剪下来。我们建议使用分模线刮刀来处理零件。组装时你还需要用到模型胶水。你可以从 Games Workshop 处购买到 Citadel Fine Detail Cutter 模型剪、Citadel Mouldline Remover 分模线刮刀和 Citadel Plastic Glue 模型胶，但 16 岁以下儿童不得在没有成年人监护的情况下使用这些产品。

EXPLANATION OF SYMBOLS | EXPLICATION DES SYMBOLES | EXPLICACIÓN DE SÍMBOLOS | ERLÄUTERUNG DER SYMBOLE | LEGENDA DEI SIMBOLI | アイコン解説 | 符号说明

- 
 - Special instruction - take care
 - Instruction spéciale - faites attention
 - Instrucciones especiales - presta atención
 - Besondere Anweisung - bitte beachten
 - Istruzioni speciali: prestare attenzione
 - 特記事項 - 要注意
 - 特别说明 - 小心
- 
 - Variant assembly
 - Variante d'assemblage
 - Variante de montaje
 - Bauvariante
 - Assemblaggio alternativo
 - 組み立てバリエーション
 - 多种组装方式
- 
 - Choice of parts
 - Choix d'éléments
 - Modelos de componentes
 - Auswahl an Teilen
 - Scelta di componenti
 - パーツの選択
 - 选择部件
- 
 - Build the number required, up to the limit shown
 - Assembler le nombre requis, jusqu'à la limite indiquée
 - Monta la cantidad requerida, hasta el límite mostrado
 - Bau die benötigte Anzahl, bis zum angegebenen Limit
 - Assembla il numero richiesto, fino al limite indicato
 - 示されている上限を超えないように、必要数を組み立てること
 - 按要求数量组装直至上限
- 
 - Build this many
 - Assembler cette quantité
 - Monta esta cantidad
 - Angegebene Anzahl bauen
 - Assembla il numero indicato
 - この数だけ組み立てること
 - 重复步骤
- 
 - COMBAT PATROL**
 - Combat Patrol assembly
 - Assemblage de Patrouille
 - Montaje de Patrulla
 - Zusammenbau der Kampfpatrouille
 - Assemblaggio della Pattuglia da Combattimento
 - コンバットパトロール用の組み立て
 - 战斗巡逻队组装
- 
 - CP**
 - Stage complete
 - Étape terminée
 - Paso completado
 - Schritt abgeschlossen
 - Fase completa
 - このステージの完了
 - 完成
- 
 - Do not glue the components
 - Ne pas coller les éléments
 - No pegar los componentes
 - Bitte die Teile nicht kleben
 - Non incollare i componenti
 - このパーツは接着不可
 - 请勿粘接
- 
 - Dry fit stage before gluing
 - Tester avant de coller
 - Comprobar el encaje antes de pegar
 - Positionierung erst ohne Klebstoff ausprobieren
 - Prova a secco prima di incollare
 - 接着前にぴったり合わせること
 - 粘接前的假组阶段

BUILD VARIANTS | VARIANTES D'ASSEMBLAGE | VARIANTES DE MONTAJE | BAUVARIANTEN | VARIANTI D'ASSEMBLAGGIO | バリエーション | 变体版

- 
 - Assemblies for build variants are indicated throughout. To play Combat Patrol games, please choose and build according to the relevant Combat Patrol army list.
 - Les variantes d'assemblage sont indiquées au fur et à mesure. Pour jouer au format Patrouille, choisissez les options conformes à la liste d'armée de Patrouille correspondante.
 - Verás indicados montajes alternativos. Para jugar partidas de Patrulla, elige y monta de forma que se adecue a la lista de ejército de Patrulla relevante.
 - Bauvarianten sind im Folgenden aufgeführt. Um Kampfpatrouille-Spiele zu spielen, wähle und baue bitte gemäß der entsprechenden Kampfpatrouille-Armeehiste.
 - Gli assemblaggi per le varianti sono indicati mano mano. Per giocare partite Pattuglia da Combattimento scegli e assembla quelle della relativa lista dell'armata Pattuglia da Combattimento.
 - 異なるバリエーションを作る場合の組み立て方法はその都度指示されています。コンバットパトロール形式のゲームをプレイする場合は、対応するコンバットパトロール用アーミーリストに従ってバリエーションを選択し、組み立ててください。
 - 您还能发现可选方案的组装方式，进行战斗巡逻游戏时，请按照相应的战斗巡逻军队列表进行组装。



A



B

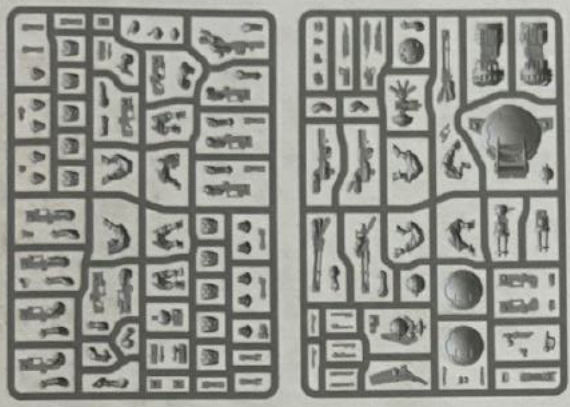

C

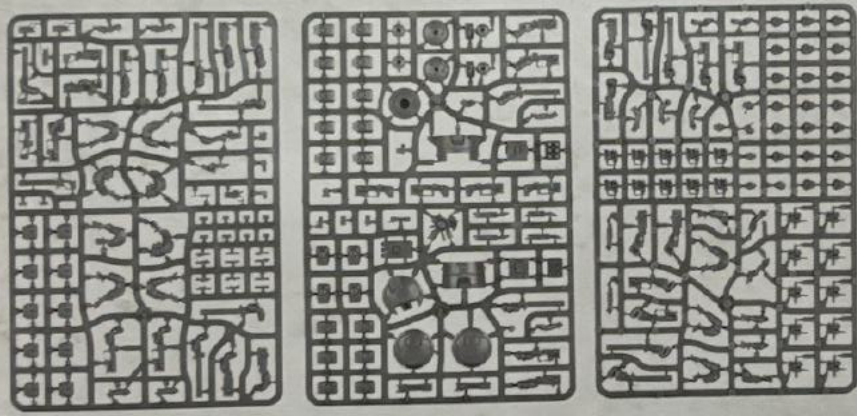

D

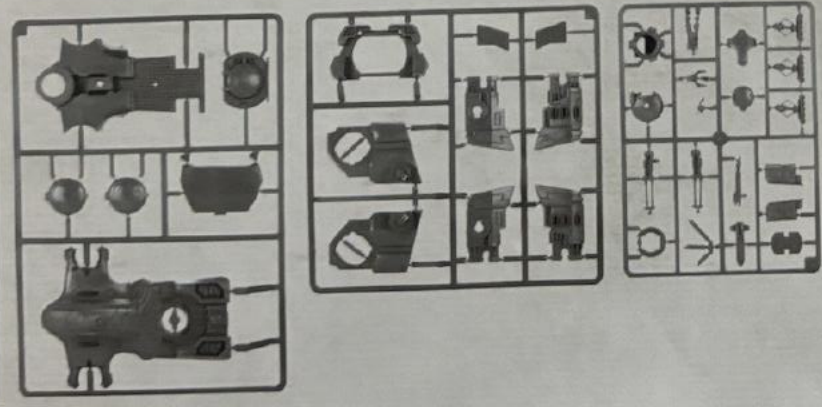

E
x2

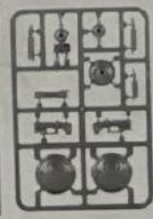

Ø
25mm
x20

Ø
40mm
x1

Ø
60mm
x1

Ø
x10

Ø
x1

x1

x6

x2



x3



x1

CHOOSE THE UNIT YOU WANT TO BUILD | CHOISISSEZ L'UNITÉ À ASSEMBLER | ESCOGE LA UNIDAD QUE QUIERES MONTAR | WÄHLE DIE EINHEIT, DIE DU BAUEN MÖCHTEST
 SCEGLI L'UNITÀ CHE VUOI ASSEMBLARE | 組み立てたいユニットを選択 | 选择您想拼装的单位

COMBAT PATROL ASSEMBLY



COMMANDER IN ENFORCER BATTLESUIT

COMMANDANT EN EXO-ARMURE ENFORCER | COMANDANTE EN EXOSQUELETO SENTENCIADOR
 COMMANDER IN VOLLSTRECKER-KAMPFANZUG | COMANDANTE IN ESOSCHELETRO ENFORCER
 コマンダー(エンフォーサー・バトルスーツ装備) | 执行者战斗装具指挥官

STEPS | ÉTAPES | PASOS | SCHRITTE
 FASI | ステップ | 步骤

1 - 3 ; 6 - 7



COMMANDER IN COLDSTAR BATTLESUIT

COMMANDANT EN EXO-ARMURE COLDSTAR | COMANDANTE EN EXOSQUELETO ESTRELLA DE HIELO
 COMMANDER IN KALTSTERN-KAMPFANZUG | COMANDANTE IN ESOSCHELETRO COLDSTAR
 コマンダー(コールドスター・バトルスーツ装備) | 冷星战斗装具指挥官

STEPS | ÉTAPES | PASOS | SCHRITTE
 FASI | ステップ | 步骤

1 - 2 ; 4 - 6

WARGEAR | ÉQUIPEMENT | EQUIPO | AUSRÜSTUNG | EQUIPAGGIAMENTO | ウォーギア | 武器装备

COMBAT PATROL



- Airbursting fragmentation projector
- Lanceur de charges à dispersion
- projector de descarga aérea
- Streugranatwerfer
- Proiettore a frammentazione ad area
- エアバースティング・フラグメンテーション・プロジェクトター
- 空爆破片发射器



- Burst cannon
- Canon à induction
- cañón rotativo
- Bündelkanone
- Cannone a salva d'impulsi
- バーストキャノン
- 速射炮



- Cyclic ion blaster
- Cyclo-éclateur à ions
- ciclobláster iónico
- Zyklischer Ionenblaster
- Fucile a ioni ciclico
- サイクリック・イオンブラスター
- 循环离子炮



- Fusion blaster
- Éclateur à fusion
- bláster fundidor
- Fusionsblaster
- Fucile a fusione
- フュージョンブラスター
- 融合炮



- High-output burst cannon
- Canon à induction surcadencé
- cañón rotativo de alta cadencia
- Hochleistungsbündelkanone
- Cannone a salva d'impulsi ad alto rendimento
- 高出力バーストキャノン
- 高能速射炮

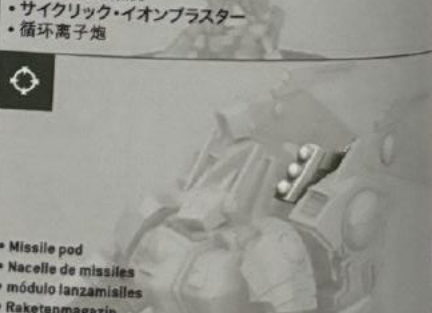

- Missile pod
- Nacelle de missiles
- módulo lanzamisiles
- Raketenmagazin
- Gondola di missili
- ミサイルポッド
- 导弹舱

COMBAT PATROL



- Plasma rifle
- Fusil à plasma froid
- fusil de plasma
- Plasmagewehr
- Fucile lungo plasma
- プラズマライフル
- 等离子步枪



- T'au flamer
- Lance-flammes T'au
- lanzallamas T'au
- T'au-Flammenwerfer
- Lanciamagma t'au
- タウ・フレイマー



- Battlesuit fists
- Poings d'exo-armure
- puños de exoarmadura
- Kampfanzugäuste

3 c

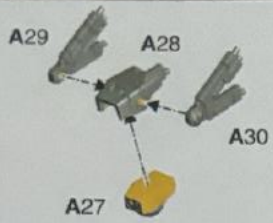

3 b

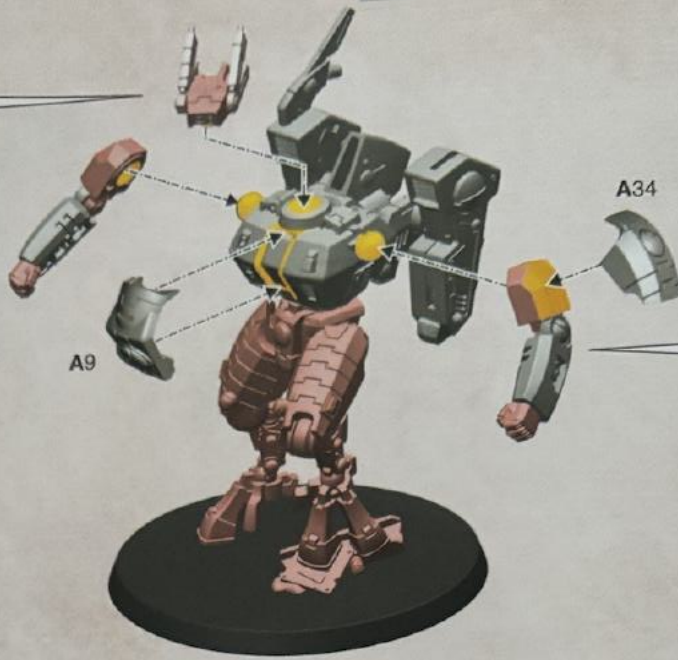

3 d



COMBAT PATROL

A57



A65



COMBAT PATROL



A66



A53



A58



A56



A62



A60



A54



3 e

3 d

A67



✓



4 - 5



COMMANDER
IN COLDSTAR BATTLESUIT

COMMANDANT EN EXO-ARMURE COLDSTAR | COMANDANTE EN EXOSQUELETO ESTRELLA DE HIELO | COMMANDER IN KALJSTERN-KAMPFANZUG
 COMANDANTE IN ESOSCHELETRO COLDSTAR | コマンダー(コールドスター・バトルスーツ装備) | 冷星战斗装具指挥官

4

1

A45

A44

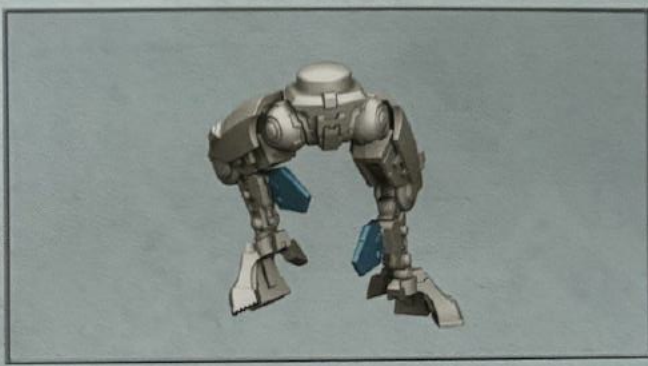
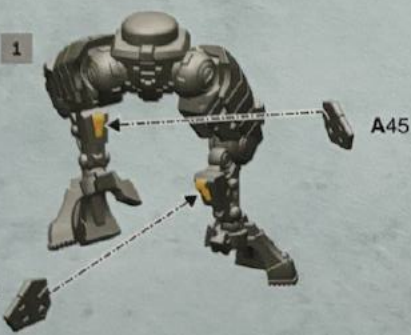

5 a

A65

A42

A41

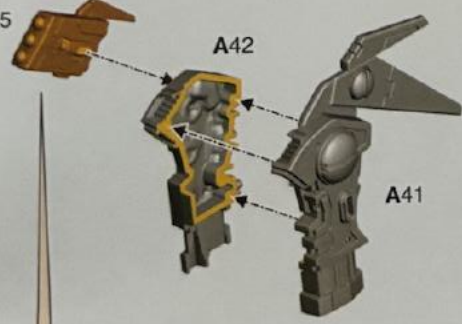

2

A43

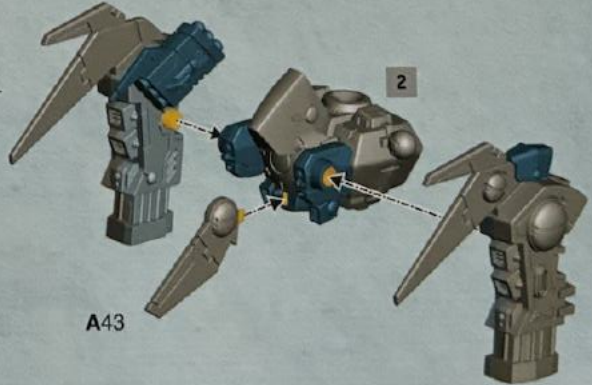

A66

A65

A57



A53

A58

A56



A48

A39

A40



5 b

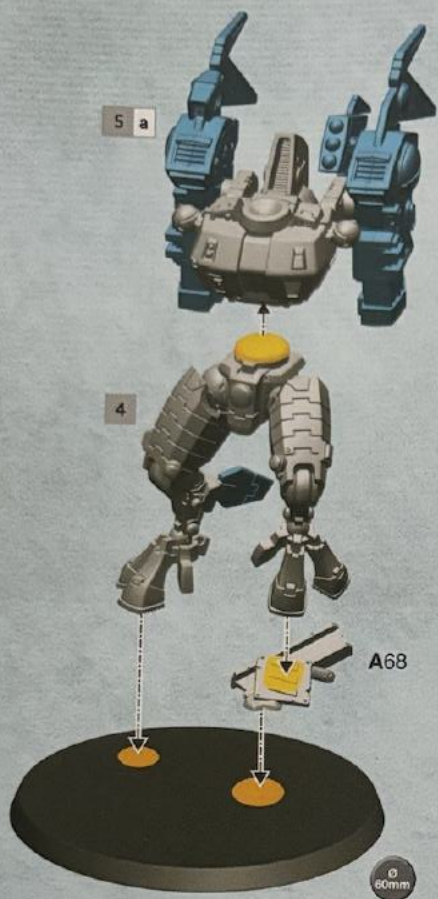

5 a

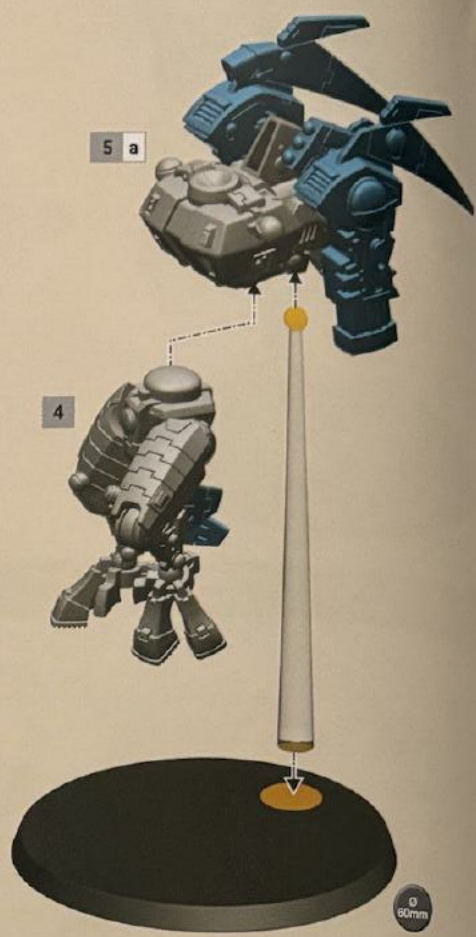

5 c

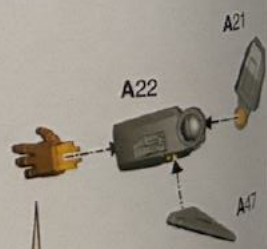
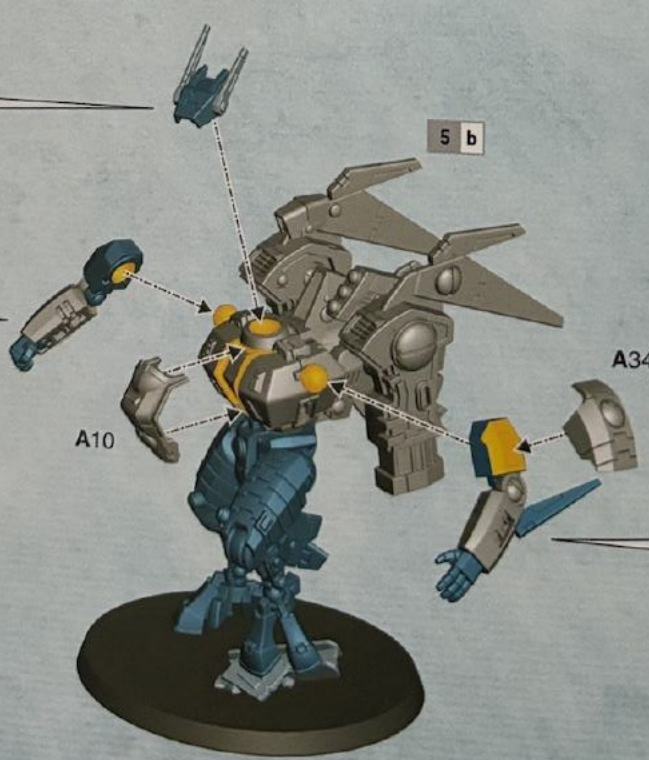
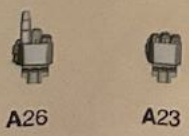
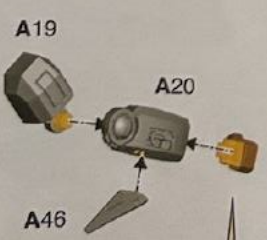
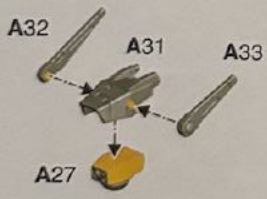

5 d

5 c

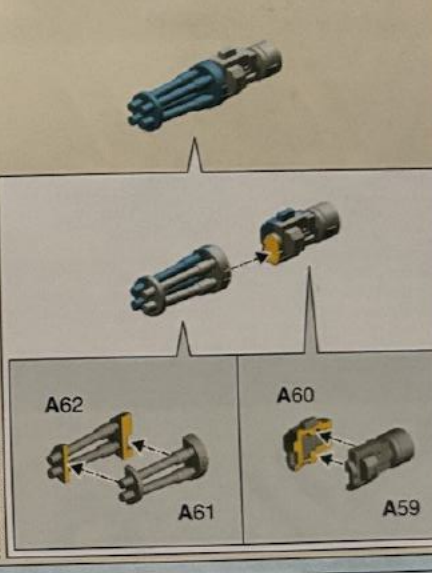
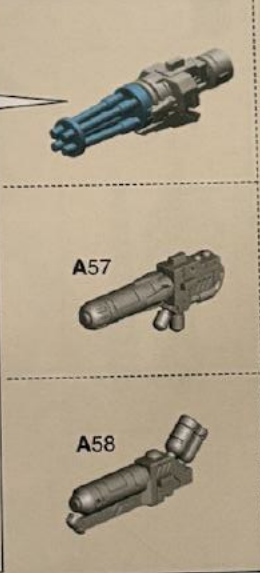
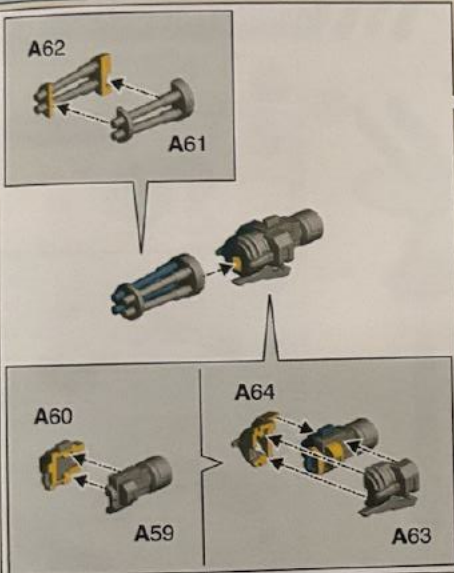
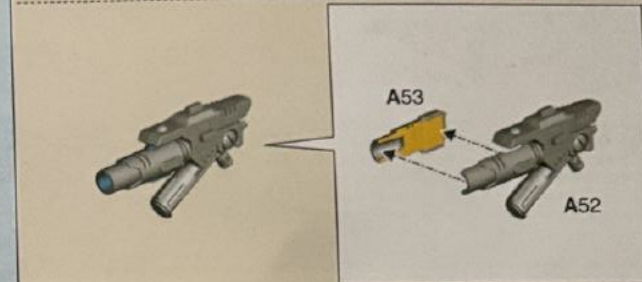
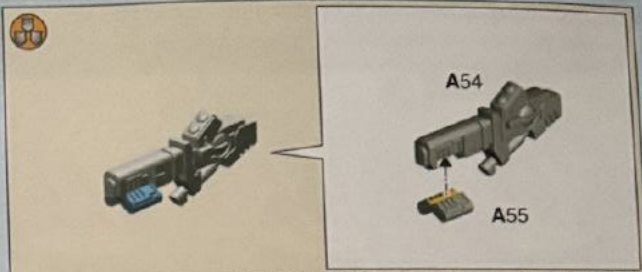

5 e

5 d



! 6

- Choose the variant you want to build
- Choisissez la variante à assembler
- Elige qué versión quieres montar
- Wähle die Variante, die du bauen möchtest

- Scegli la variante che vuoi assemblare
- 組み立てバリエーションの選択
- 选择你喜欢的拼装方式

COMBAT PATROL



- Shield Drone
- Drone Bouclier
- Dron de defensa
- Schilddrohne
- Drone Scudo
- シールド・ドローン
- 护盾无人机



- Marker Drone
- Drone de Marquage
- Dron telemétrico
- Markiererdrohne
- Drone Tracciatore
- マーカー・ドローン
- 标记无人机



- Gun Drone
- Drone Armé
- Dron de combat
- Angriffsdrohne
- Drone Arma
- ガン・ドローン
- 火炮无人机

A76 A77



A69



! 7

COMBAT PATROL



- Shield Drone
- Drone Bouclier
- Dron de defensa
- Schilddrohne
- Drone Scudo
- シールド・ドローン
- 护盾无人机



- Marker Drone
- Drone de Marquage
- Dron telemétrico
- Markiererdrohne
- Drone Tracciatore
- マーカー・ドローン
- 标记无人机



- Gun Drone
- Drone Armé
- Dron de combat
- Angriffsdrohne
- Drone Arma
- ガン・ドローン
- 火炮无人机

7 a



E1

E2

E3

E10

7 b

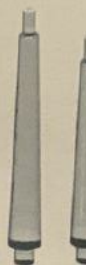

7 a

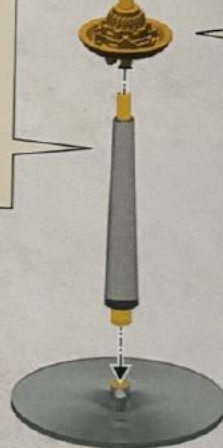

COMBAT PATROL ASSEMBLY



- Drone burst cannon
- Canon à induction de drone
- cañón rotativo de dron
- Drohnenbündelkanone
- Cannone a salva d'impulsi del drone
- ドローン・バーストキャノン
- 无人机速射炮



- Ion rifle
- Fusil à ions
- rifle iónico
- Ionengewehr
- Fucile lungo a ioni
- イオンライフル
- 离子步枪



COMBAT PATROL

- Pulse carbine
- Carabine à impulsion
- carabina de inducción
- Pulsekarabiner
- Carabina a impulsii
- パルスカービン
- 脉冲卡宾枪



COMBAT PATROL

- Pulse pistol
- Pistolet à impulsions
- pistola de inducción
- Pulsepistole
- Pistola a impulsii
- パルスピストル
- 脉冲手枪



COMBAT PATROL

- Rail rifle
- Fusil-rail
- rifle acelerador
- Messebeschleunigungsgewehr
- Fucile lungo a rotaia
- レールライフル
- 磁軌步枪



8 x10



B5 x10



B6 x2



B7 x2



B8



B9



B10 x2



B11 x2

B14



B15



B54

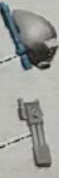

B41



B48



B2





B3



B4



B53

10 a-b



10 a

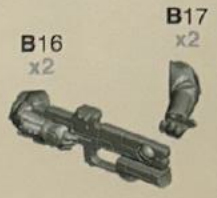
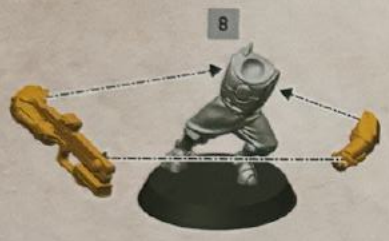

10 b

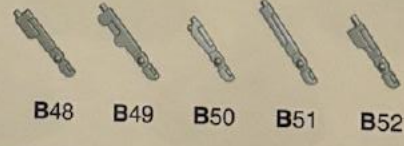

10 c

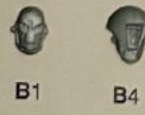

11 x3

11 a

COMBAT PATROL

x3



11 b



11 a



B36

B38

B40

COMBAT PATROL

x3

8

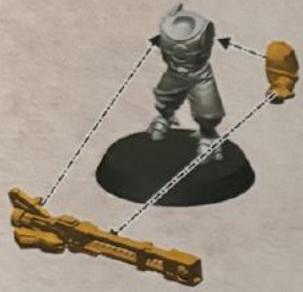

B35

B43

B37

B43

B39

B43



11 b



B30

B32

B34

8



B29

B31

B33

B42

B42

B42



11 c

10 a/b



B1

B4



B48

B49

B50

B51

B52



9 - 11



- | | | | | | | | |
|-----|-----|-----|-----|-----|-----|-----|-----|
| B20 | B55 | B56 | B57 | B58 | B59 | B60 | B61 |
| B62 | B63 | B64 | B65 | B66 | B67 | B68 | B69 |



! 13 x2

COMBAT PATROL x1

<ul style="list-style-type: none"> • Grav-Inhibitor Drone • Drone Inhibiteur • Dron AntiGravedad • GravInhibitordrohne • Drone Inibitore Grav • グラヴィンヒビター・ドローン • 重力抑制無人機 	<ul style="list-style-type: none"> • Shield Drone • Drone Bouclier • Dron de defensa • Schilddrohne • Drone Scudo • シールド・ドローン • 护盾无人機 	<ul style="list-style-type: none"> • Pulse Accelerator Drone • Drone Impulseur • Dron Acelerador de inducción • Pulsbeschleunigerdrohne • Drone Acceleratore di Impulsi • パルスアクセラレーター・ドローン • 脉冲加速无人機 	<ul style="list-style-type: none"> • Gun Drone • Drone Armé • Dron de combate • Angriffsdrohne • Drone Arma MV1 • ガン・ドローン • 火炮无人機 	<ul style="list-style-type: none"> • Marker Drone • Drone de Marquage • Dron telemétrico • Markierdrohne • Drone Tracciatore • マーカー・ドローン • 标记无人機
---	--	---	--	---

COMBAT PATROL x1

B82 B81

B78

B79 B80

B88 B89 B90

B83 B84

B77

B85

B86

B87



14 a

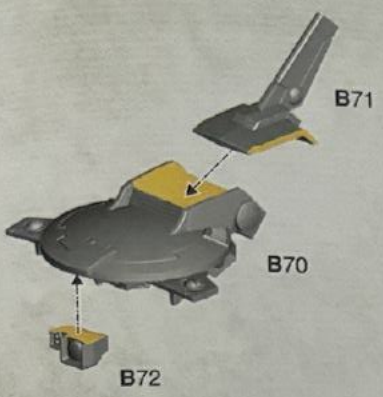

14 b

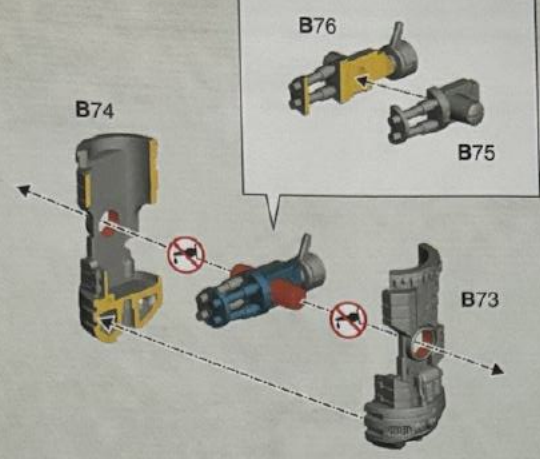

14 c

14 a

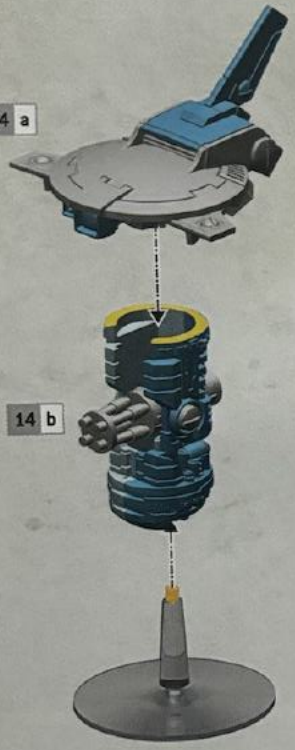

14 b

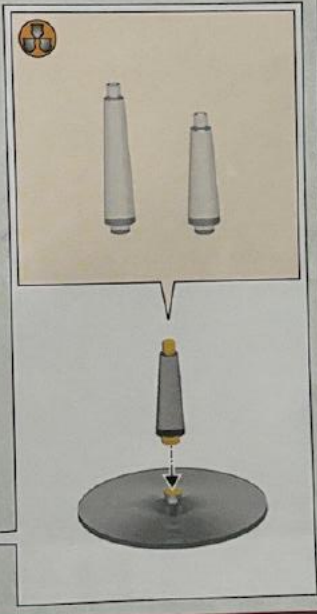

COMBAT PATROL





CHOOSE THE UNIT YOU WANT TO BUILD | CHOISISSEZ L'UNITÉ À ASSEMBLER | ESCOGE LA UNIDAD QUE QUIERES MONTAR | WÄHLE DIE EINHEIT, DIE DU BAUEN MÖCHTESTES
SCEGLI L'UNITÀ CHE VUOI ASSEMBLARE | 組み立てたいユニットを選択 | 选择您想拼装的单位



BREACHER TEAM

EQUIPE DE BRÊCHEURS | EQUIPO DE BRECHAS | ANGRIFSTEAM | TEAM DA SFONDAMENTO | ブリーチャー・チーム | 攻坚小队

COMBAT PATROL

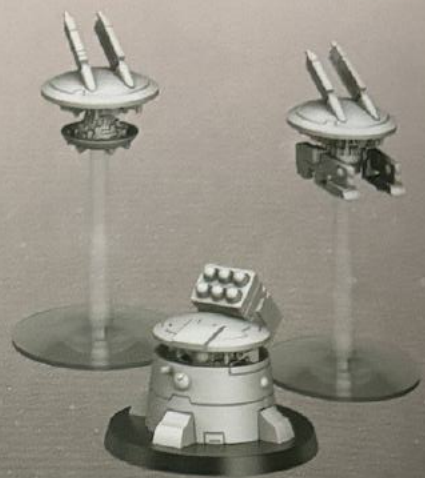

STEPS | ÉTAPES | PASOS | SCHRITTE
FASI | ステップ | 步骤

15 - 18 ; 22 - 23



STRIKE TEAM

EQUIPE D'ATAQUE | EQUIPO DE ATAQUE | EINGREIFTEAM | TEAM D'ASSALTO | ストライク・チーム | 突击小队



STEPS | ÉTAPES | PASOS | SCHRITTE
FASI | ステップ | 步骤

15 ; 19 - 23



- Pulse carbine
- Carabine à impulsions
- carabina de inducción
- Pulskarabiner
- Carabina a impulsii
- バルスカービン
- 脉冲卡宾枪



- Pulse pistol
- Pistolet à impulsions
- pistola de inducción
- Puls pistole
- Pistola a impulsii
- バルスピストル
- 脉冲手枪

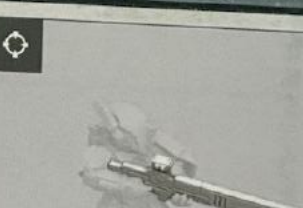

- Pulse rifle
- Fusil à impulsions
- rifle de inducción
- Pulsgewehr
- Fucile lungo a impulsii
- バルスライフル
- 脉冲步枪



- Support turret
- Tourelle d'appui
- Torreta de apoyo
- Unterstützungsturm
- Torretta di supporto
- サボータレット
- 支援炮台

15 x10



C40 x3
 C41 x2
 C42 x2
 C43 x1
 C44 x3
 C45 x2
 C46 x2

Ø 25mm

16 x1 Breacher Fire Warrior Shas'ui | Shas'ui Brêcheur Guerrier de Feu | Shas'ui Irruptor de la Casta del Fuego | Angriffssteam-Feuerkrieger-Shas'ui | Guerriero del Fuoco da Sfondamento Shas'ui

C48 C61
 C57 C59 C64
 C58 C25
 C2 C3 C4 C5
 C34 C35 C36 C37 C38 C39

Assembly steps for Breacher Fire Warrior Shas'ui (Step 16). The figure is shown in various stages of construction, with callouts for parts C48, C61, C57, C59, C64, C58, C25, C2, C3, C4, C5, C34, C35, C36, C37, C38, C39, and C49. A final assembled figure is shown on the right.

17 x9 Breacher Fire Warriors | Brêcheur Guerrier de Feu | Irruptor de la Casta del Fuego | Angriffssteam-Feuerkrieger | Guerriero del Fuoco da Sfondamento | プリーチャー・ファイアウォリアー | 烈火战士破袭者

C9 C48
 C9 C49
 C2 C6 C7 C8
 C34 C35 C36 C37 C38 C39

Assembly steps for Breacher Fire Warriors (Step 17). The figure is shown in various stages of construction, with callouts for parts C9, C48, C49, C2, C6, C7, C8, C34, C35, C36, C37, C38, C39.

x2 C10 C13 C16 C17 C20 C21 C52 C56
 x2 C24 C25 x2 C28 C29 x2 C32 C33 F

Parts list for Breacher Fire Warriors (Step 17). The list includes: x2 C10, C13, C16, C17, C20, C21, C52, C56, x2 C24, C25, x2 C28, C29, x2 C32, C33, and F.

18 x10
 C66 x3 C65
 C67 C68 C69 C70 C71
 C72 C73 C74 C75 C76 C77

Assembly steps for Breacher Fire Warriors (Step 18). The figure is shown in various stages of construction, with callouts for parts C66 x3, C65, C67, C68, C69, C70, C71, C72, C73, C74, C75, C76, C77. A final assembled figure is shown on the right.



19 x1

Fire Warrior Shas'ui | Shas'ui Guerrier de Feu | Shas'ui de la Costa del Fuego | Feuerkrieger-Shas'ui | Guerriero del Fuoco Shas'ui | ファイアウォリアー・シャス=ウィ | 烈火战士老兵

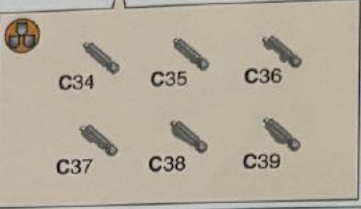
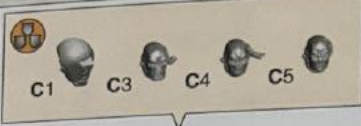

20 x9

Fire Warriors | Guerriers de Feu | Guerreros del Fuego | Feuerkrieger | Guerrieri del Fuoco | ファイアウォリアー | 烈火战士

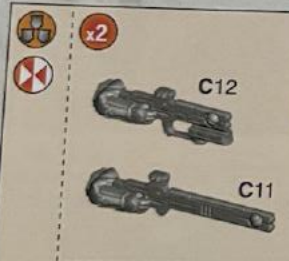
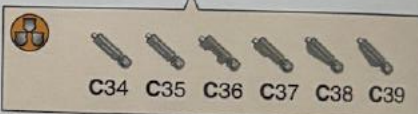
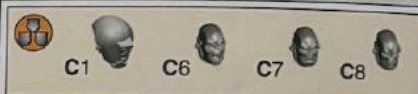

21 x10

19 - 20

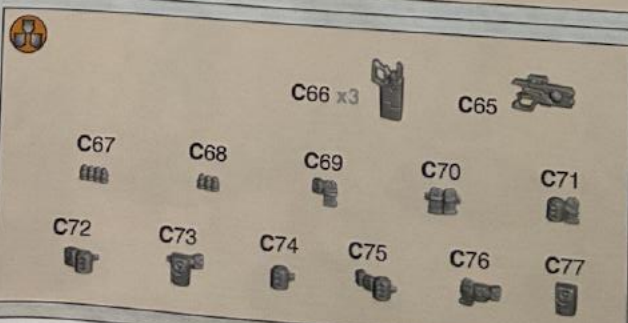



22 Support Turret
 Tourrelle d'Appui
 Torre de apoyo
 Unterstützungsturm
 Torretta di Controllo
 サポートタレット
 支援砲台

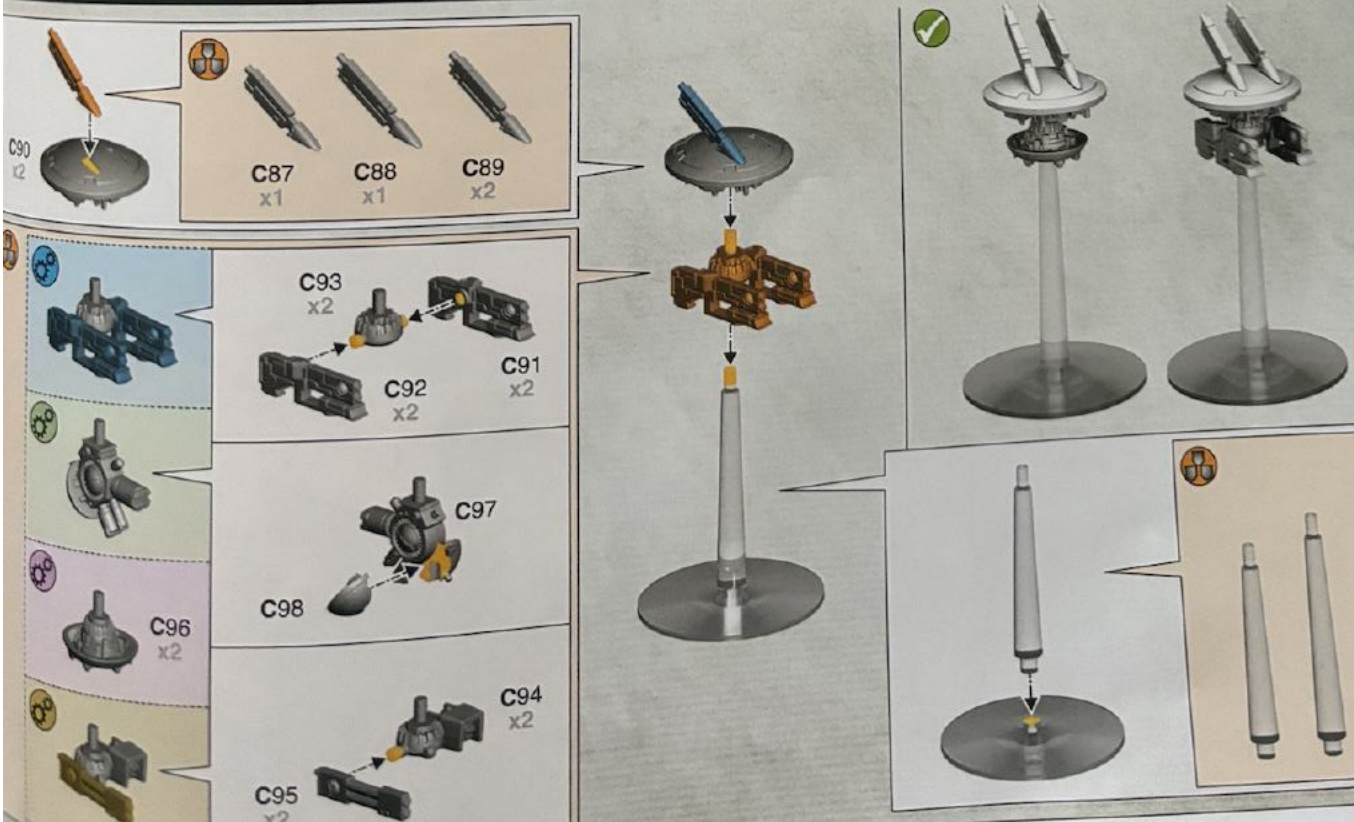
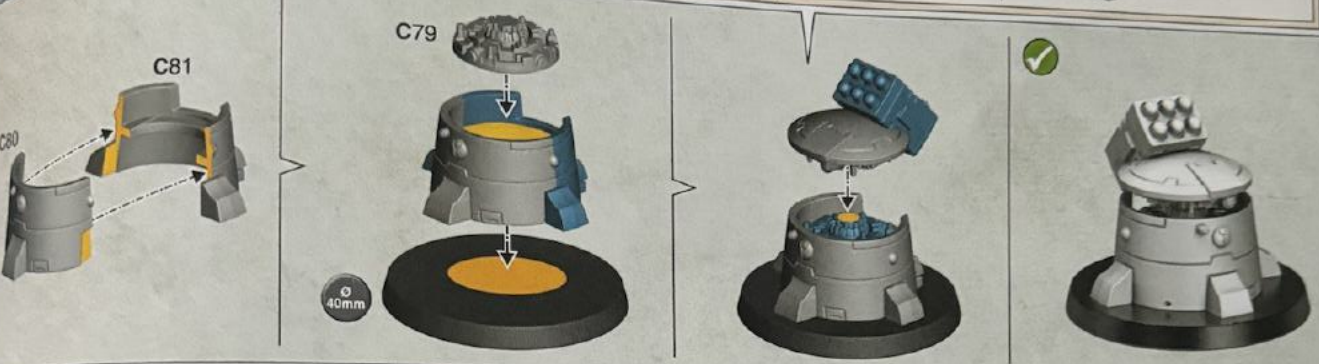
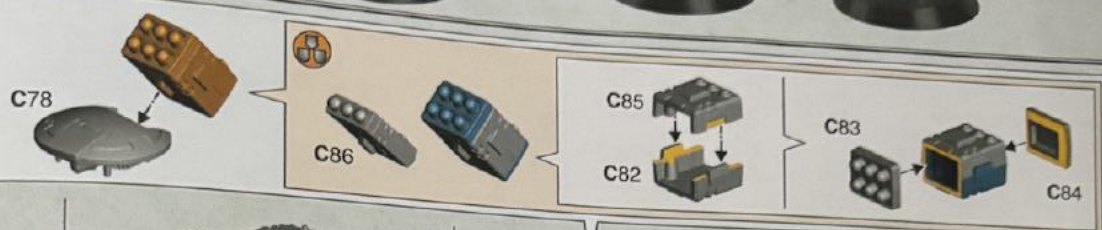

COMBAT PATROL

COMBAT PATROL



- Accelerator burst cannon
- Canon à induction accéléré
- cañón rotativo de aceleración
- Beschleuniger-Bündelkanone
- Cannone a salva d'impulsi Accelerator
- アクセラレータ・バーストキャノン
- 加速連射砲

- Seeker missile
- Missile Seeker
- misil buscador
- Lenkrakete
- Missile a ricerca
- シーカーミサイル
- 探索者导弹

- Twin pulse carbine
- Carabine à impulsions jumelée
- carabina de inducción doble
- Zwillingspulskarabiner
- Doppia carabina a impulsi
- ツイン・パルスカービン
- 双联脉冲卡宾枪

24 a

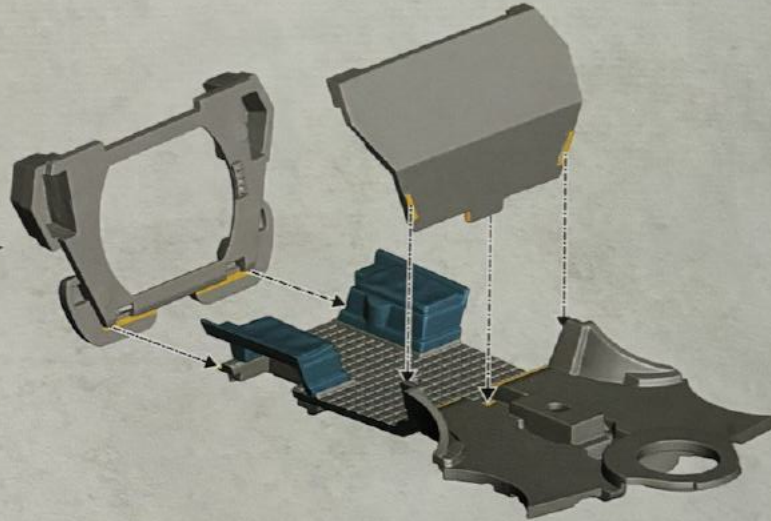
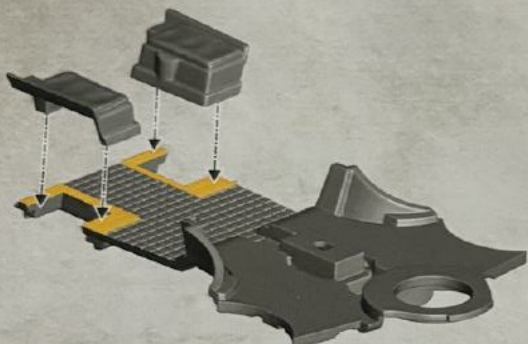

24 b

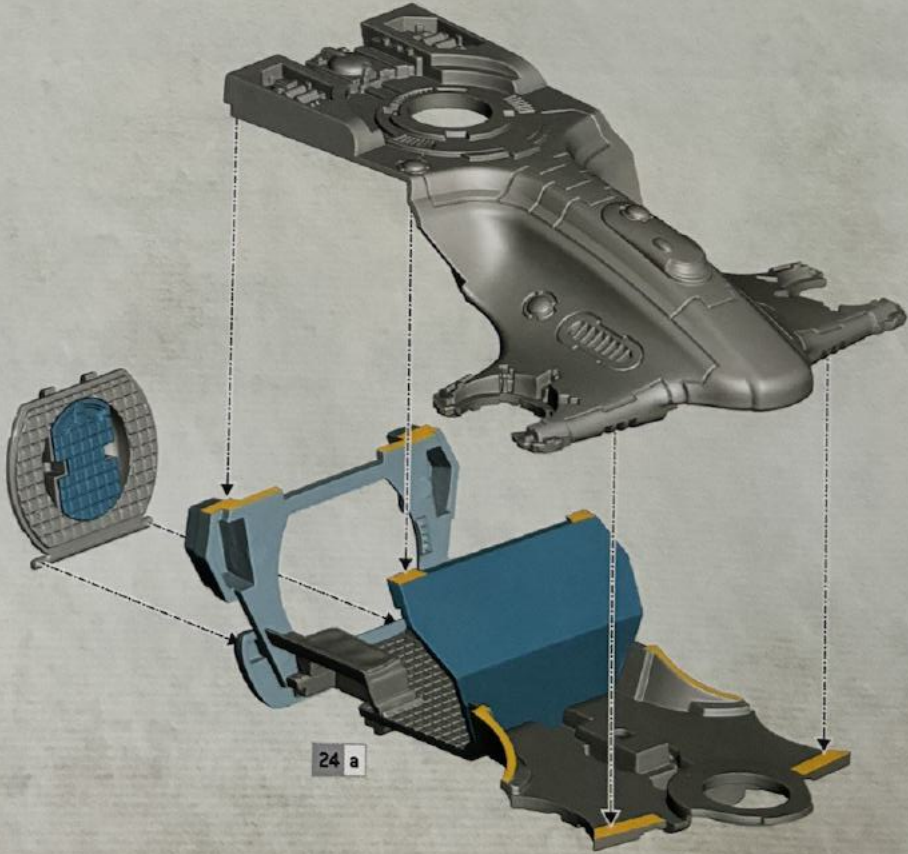
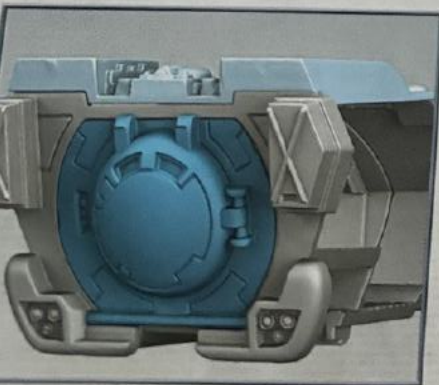
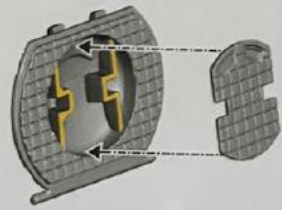

24 a

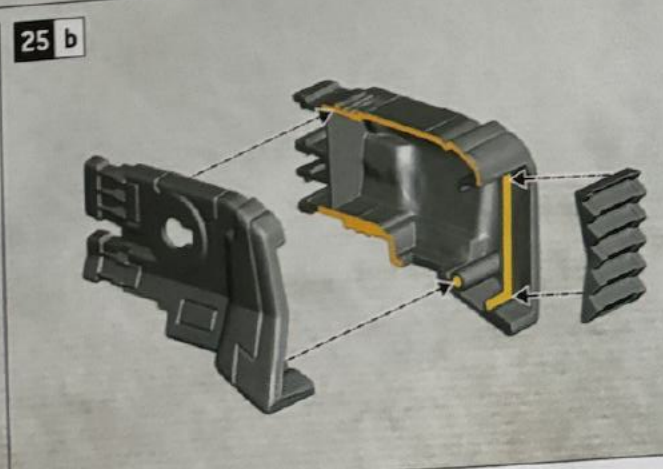
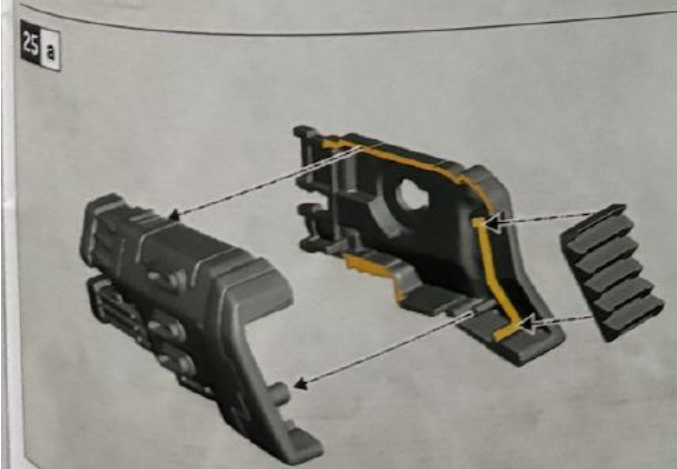
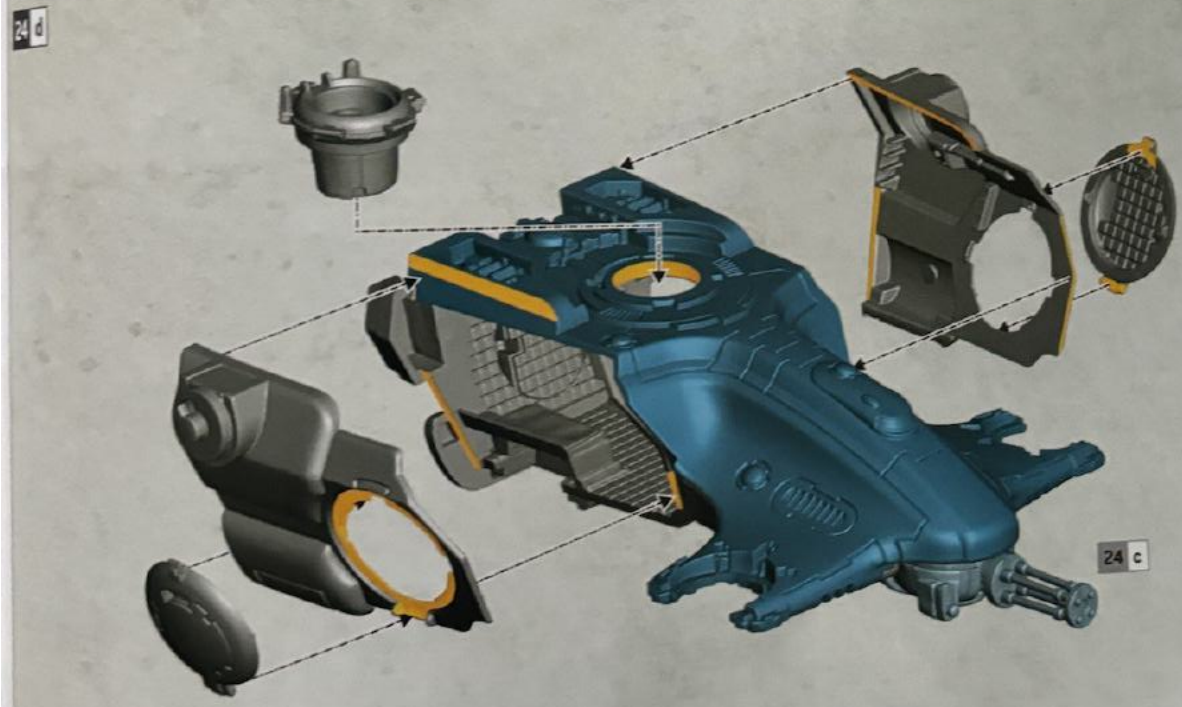
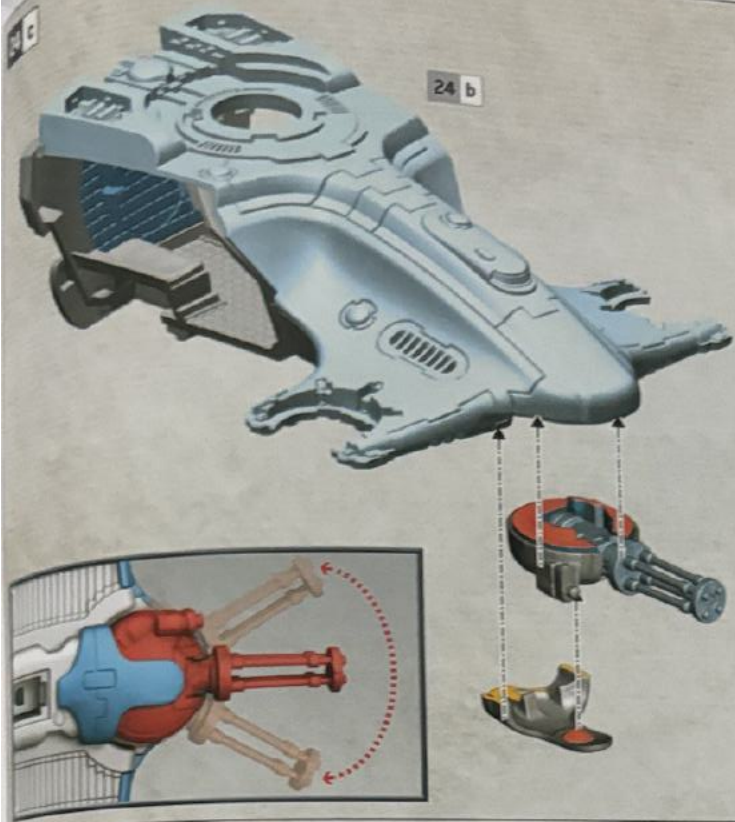

25 c



25 b



25 a



24

26 a x2

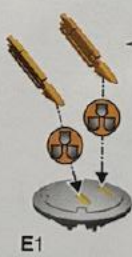

E2

E3

E10

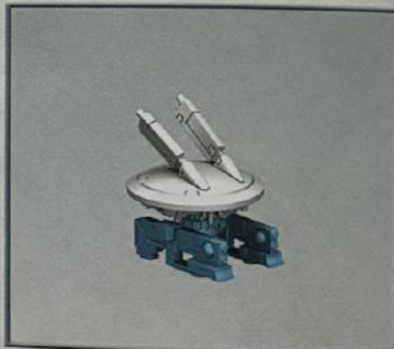

26 b



26 a

26 a



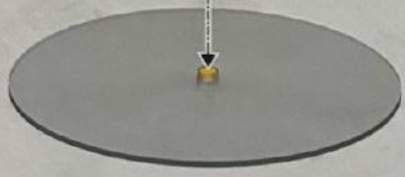
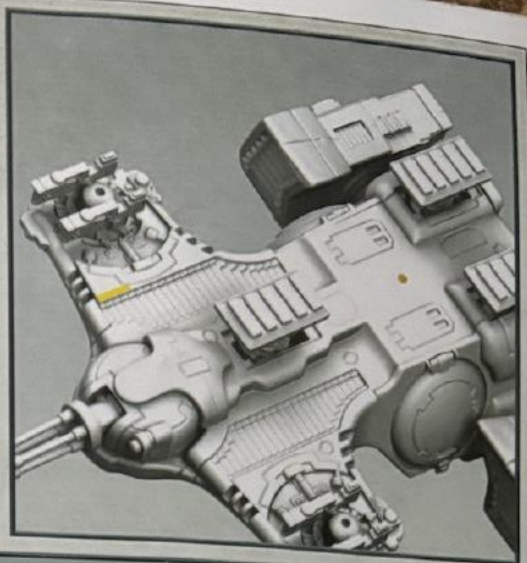
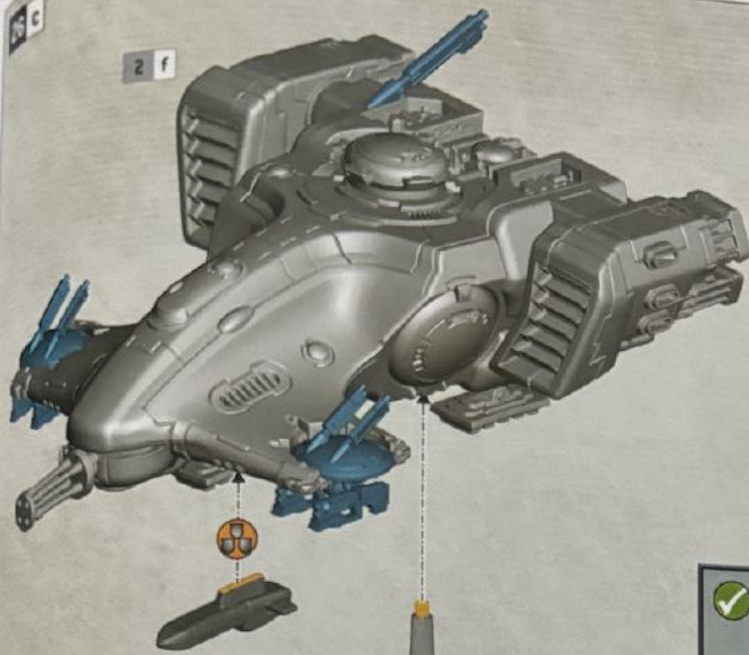

27 **x2**

<ul style="list-style-type: none"> • Shield Drone • Drone Bouclier • Dron de defensa • Schilddrohne • Drone Scudo • シールド・ドローン • 护盾无人机 	<ul style="list-style-type: none"> • Marker Drone • Drone de Marquage • Dron telemetrico • Markiererdrohne • Drone Tracciatore • マーカー・ドローン • 标记无人机 	<ul style="list-style-type: none"> • Gun Drone • Drone Armé • Dron de combat • Angriffsdrohne • Drone Arma • ガン・ドローン • 火炮无人机
--	---	---

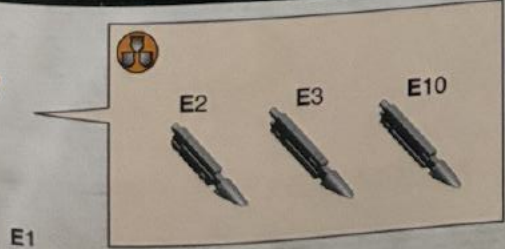
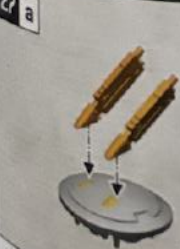

27 b

7 a

		<p>E7</p>
		<p>E8 E9</p>
		<p>E4 E5 E6</p>



ENG More painting guides can be found on citadelcolour.com
 FRE D'autres guides de peinture sont disponibles citadelcolour.com
 SPA Encontrarás más guías de pintura en citadelcolour.com
 GER Weitere Bemalanleitungen auf citadelcolour.com

ITA Puoi trovare altre guide alla pittura su citadelcolour.com
 日本語 citadelcolour.com には他にも様々なペイントガイドが掲載されている
 中文 更多涂装指南请至 citadelcolour.com



THESE RECOMMENDED CITADEL PAINTS ARE EACH AVAILABLE SEPARATELY

WHITE SCAR™	MEPHISTON RED™	RUNELORD BRASS™
AGRAX EARTHSHADE™	EVIL SUNZ SCARLET™	NULN OIL™
ADADDON BLACK™	SPACE WOLVES GREY™	BAHARROTH BLUE™
MECHANICUS STANDARD GREY™	SOTEK GREEN™	ASTROGRANITE DEBRIS™

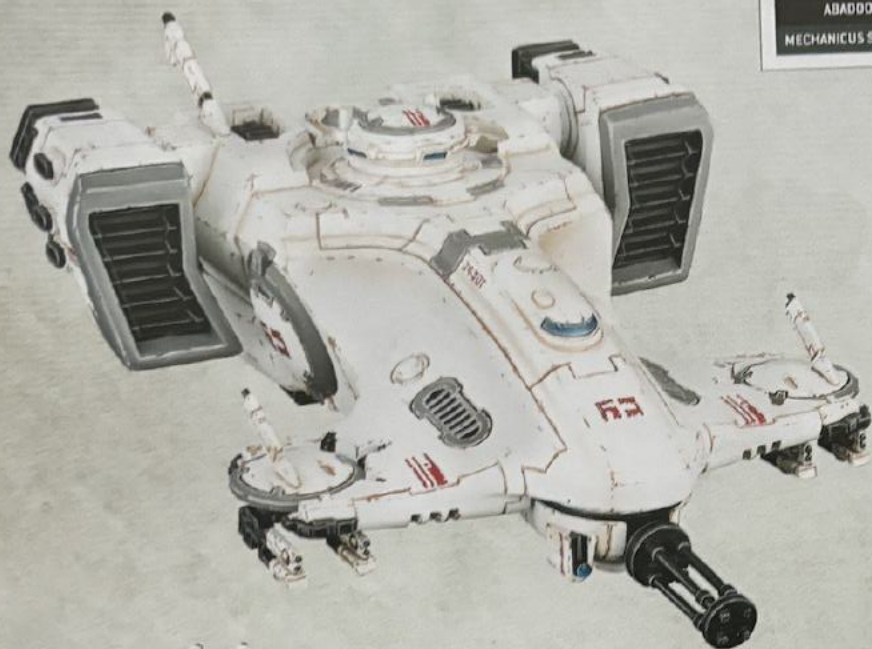

993201130396



MADE IN THE UK

WARHAMMER.COM

Games Workshop Limited, Willow Road, Nottingham, NG7 2WS, UK
 © Copyright Games Workshop Limited 2024.

