

Free Downloads of Build Instructions,
Assembly Booklets & How To Guides

BuildInstructions.com

MECHANICUM KNIGHT MOIRAX

WITH LIGHTNING LOCKS

Fitted with a potent reactor core capable of powering the most destructive weaponry available to its class, the Knight Moirax was a formidable tool in the arsenal of Questoris Households loyal to the Mechanicum. However, this energy core was notorious for radioactive instability, and so the Moirax chassis was considered to be an unseemly instrument with which to lay the foundations of the Imperium, seeing minimal use on human-occupied worlds before the darkest hours of the Horus Heresy.



THIS IS NOT A TOY

Not suitable for children under 15 years of age.

WARNING: Resin dust can be harmful if inhaled. Always wear a dust mask or respirator when sanding or sawing resin parts.

www.forgeworld.co.uk

Components

Before assembly, check that none of the components are missing. This kit makes use of plastic and resin components. Plastic components are referenced by a number on the sprue, shown in this guide as a black number on a white background. Resin components are shown here with a white number on a black background.











If you need to contact the Forge World Customer Service team regarding this model, you can get in touch via email - forgeworld@gwplc.com - or call:
0115 900 4995 within the UK
011 44 115 900 4995 from the USA and Canada
0011 44 115 900 4995 from Australia
00 44 115 900 4995 from Europe and the rest of the world.

Resin Component List

- | | |
|--------------------------------|-------------------------------------|
| 1. Shoulder Armature x2 | 18. Carapace Hood |
| 2. Left Exhaust | 19. Head 2 |
| 3. Fuselage Rear | 20. Left Shin Plate |
| 4. Right Exhaust | 21. Thigh Plate x2 |
| 5. Head Cable 1 | 22. Groin Plate |
| 6. Head Cable 2 | 23. Right Shin Plate |
| 7. Head Cable 3 | 24. Arm Pin x2 |
| 8. Head Cable 4 | 25. Right Lightning Lock Upper Coil |
| 9. Head Cable 5 | 26. Left Lightning Lock Upper Coil |
| 10. Head Cable 6 | 27. Lightning Lock Capacitor x2 |
| 11. Left Pauldron | 28. Left Weapon Plating |
| 12. Carapace | 29. Right Weapon Plating |
| 13. Right Pauldron | 30. Right Lightning Lock Cable |
| 14. Construct Shield Projector | 31. Left Lightning Lock Cable |
| 15. Arm Mount x2 | 32. Lightning Lock Barrel x2 |
| 16. Arm Hinge x2 | 33. Lightning Lock Lower Coil x2 |
| 17. Head 1 | 34. Lightning Lock Socket x2 |

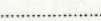

Assembly Legend

- | | |
|---------------------|---|
| Parts for Assembly |  |
| Note |  |
| Glue Contact Area |  |
| Shim for Removal |  |
| Option |  |
| Reverse Angle |  |
| Do Not Glue |  |
| Insert |  |
| Component Highlight |  |

Preparing the Model for Assembly

Before assembling the model, wash each part thoroughly with an abrasive brush, such as a toothbrush, to remove any model release agent that may still be on the surface of the parts. Then, remove any excess resin such as mould lines, casting gates, vents and shims. For a more detailed guide to working with resin models, go to the Downloads section of the Forge World website.

This kit contains all the pieces required to construct the Mechanicum Knight Moirax with Lightning Locks. To glue the resin pieces together, use Citadel Super Glue.

NOTE: We have cast this kit using advanced techniques and the best quality resin, but due to the nature of the casting process, your model may contain small air bubbles. These can easily be filled with model filler or super glue. Any slight warpage of thin parts can be corrected by immersing the part in hot water for about 1 minute, then bending it back into shape.

I

3. Fuselage Rear

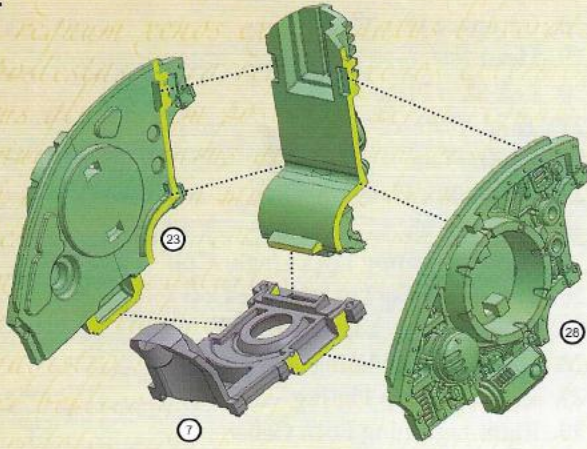

2

Torso Assembly

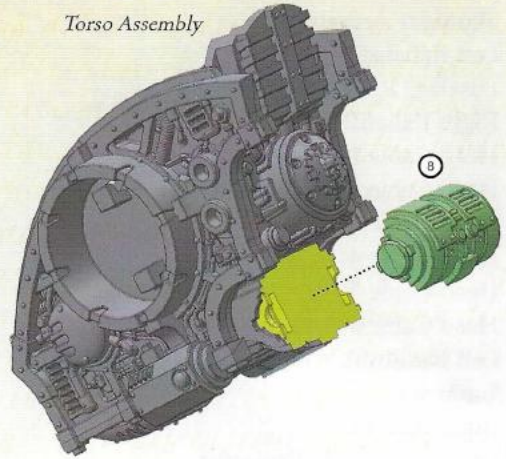

3

12. Carapace

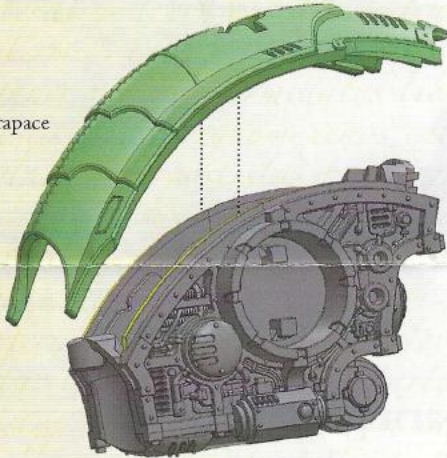

4

Torso Assembly

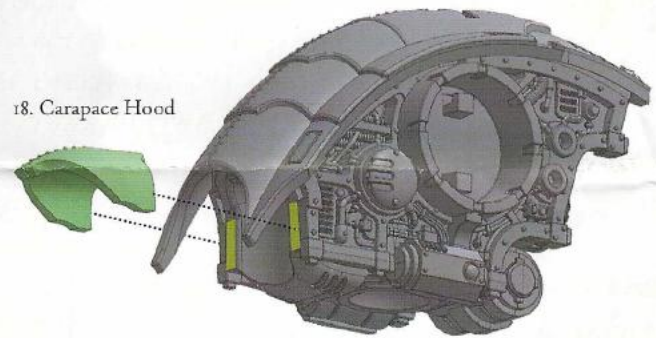

5

14. Construct Shield Projector

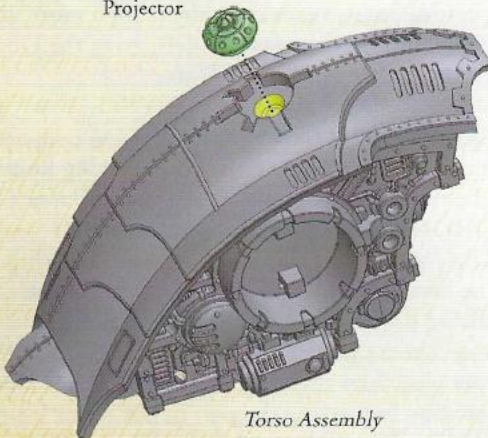

6

2. Left Exhaust

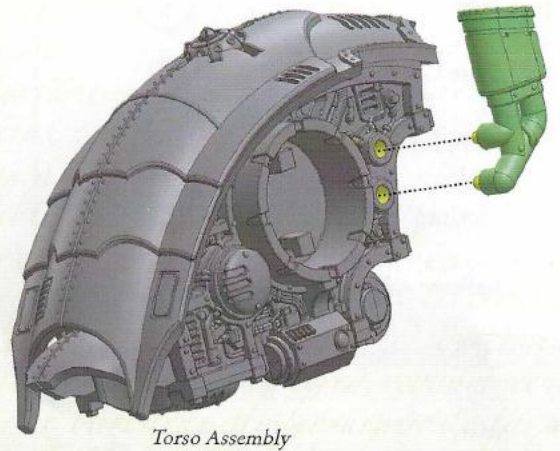

Repeat this stage with part 4. Right Exhaust on the right hand side of the torso assembly.

7

15. Arm Mount

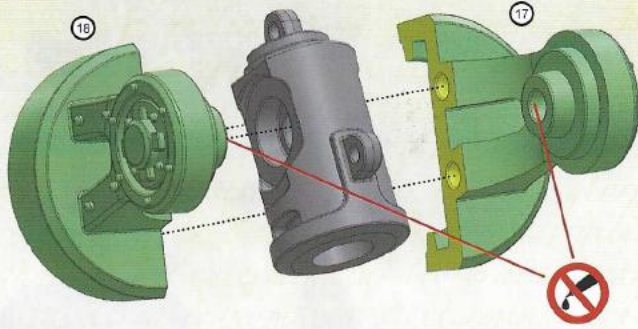

8

i. Shoulder Armature



Repeat Stages 7-10 to make both shoulder assemblies. Using part 13. Right Pauldron in stage 9.

9

ii. Left Pauldron



10

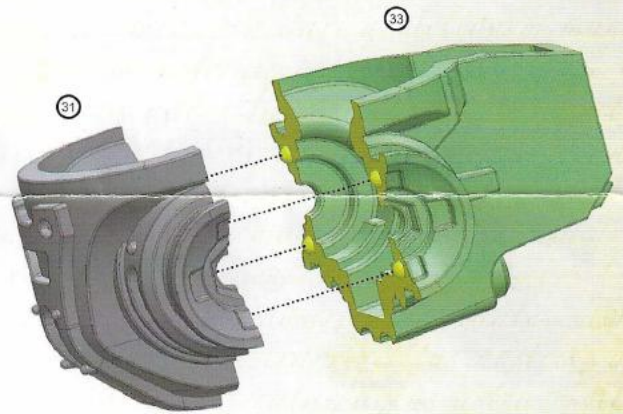

11



12

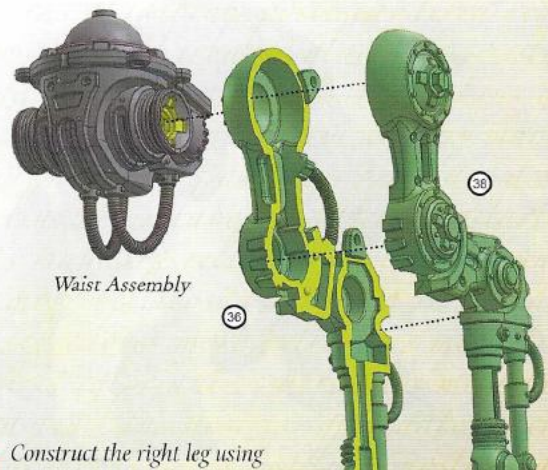

Construct the right leg using

I3

Legs Assembly



I4

Legs Assembly



I5

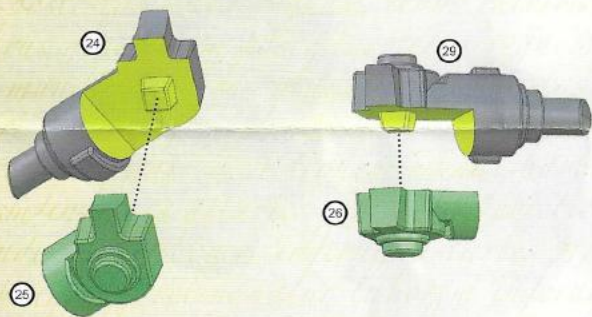

I6

Legs Assembly

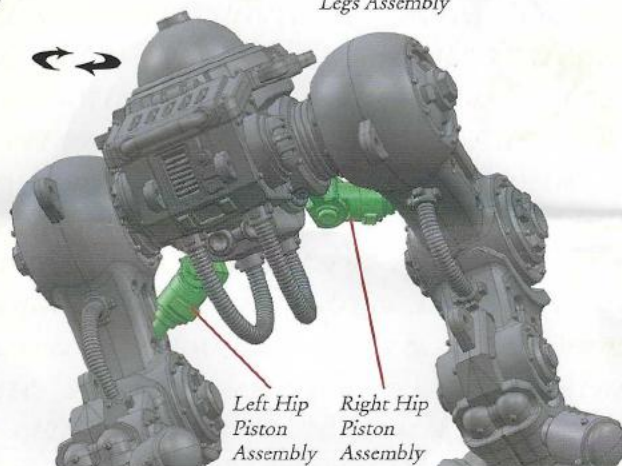

I7

Legs Assembly

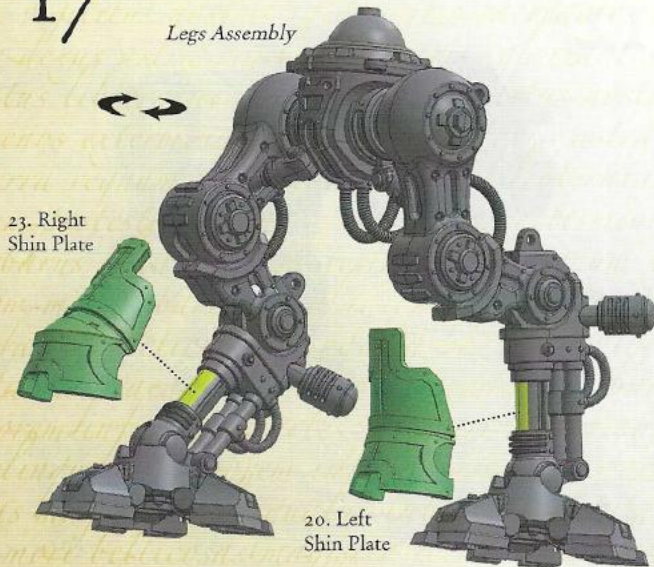

I8

Legs Assembly

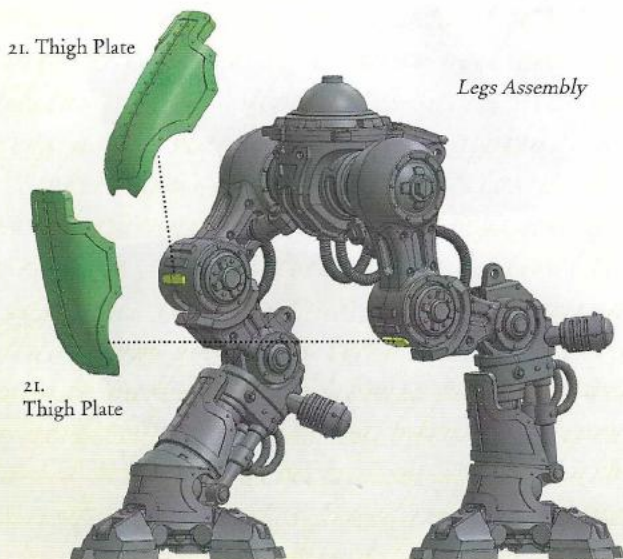

19



20



 Rotate the Shoulder Assemblies to lock them into position.

21

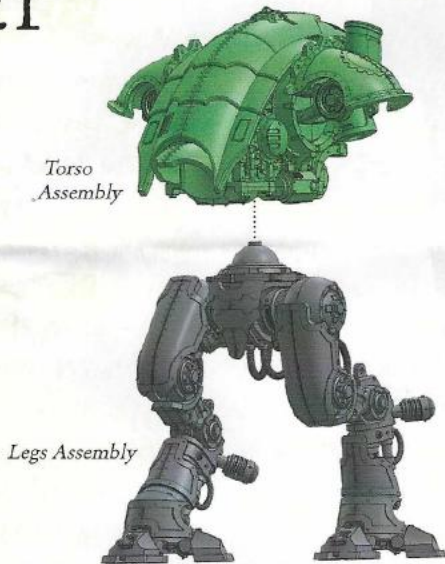

22

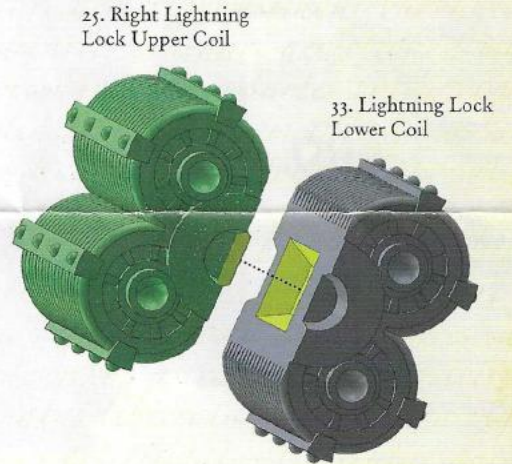

23

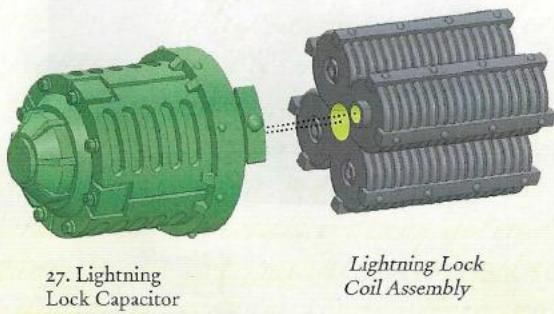

24

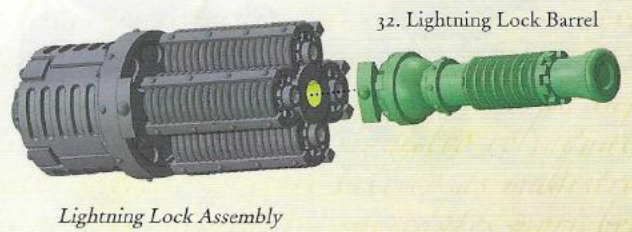

25



29. Right Weapon Plating

Lightning Lock Assembly

26

34. Lightning Lock Socket



30. Right Lightning Lock Cable

Lightning Lock Assembly

27

16. Arm Hinge
24. Arm Pin

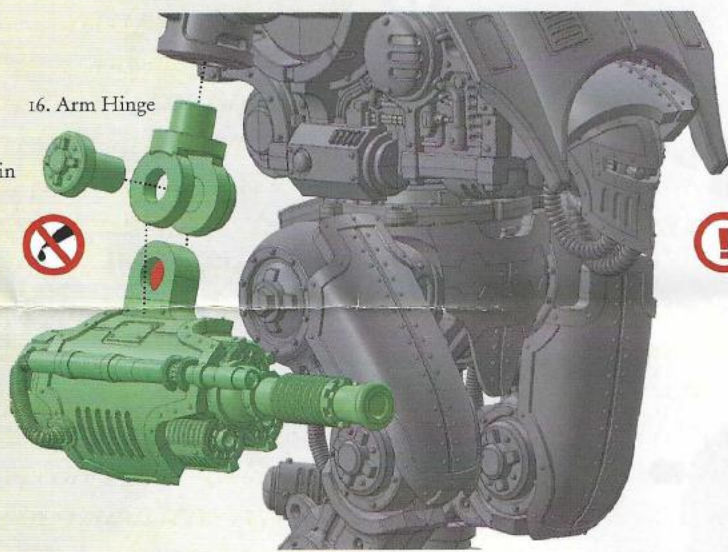

Lightning Lock Assembly

! Repeat stages 22 - 27 for the Left Lightning Lock using parts 26. Left Lightning Lock Upper Coil, 28. Left Weapon Plating and 31. Left Lightning Lock Cable.

28

17. Head 1



6. Head Cable 2
5. Head Cable 1
7. Head Cable 3

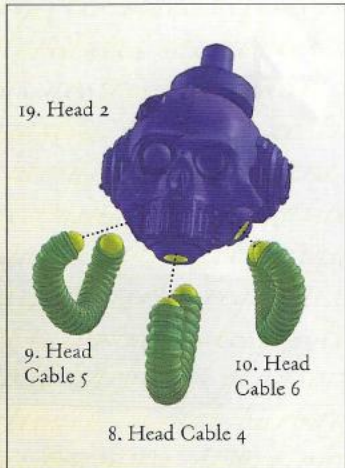

19. Head 2
9. Head Cable 5
10. Head Cable 6
8. Head Cable 4

29

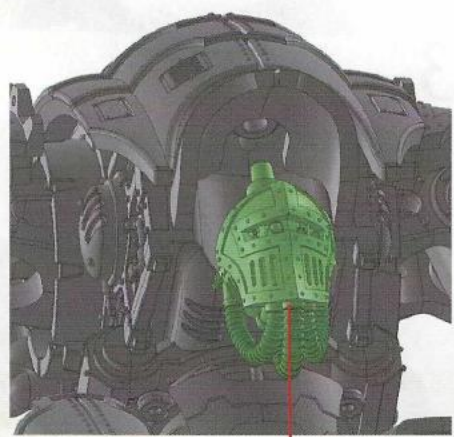

Head Assembly

! A choice of two head styles are available.

