



Free Downloads of Build Instructions,
Assembly Booklets & How To Guides

BuildInstructions.com

SPACE MARINE LEGION SABRE STRIKE TANK

Fast, rugged and heavily armed, the Sabre serves the Legiones Astartes as a strike tank, attacking key enemy targets and destroying them long before they can pose a threat to any Legiones Astartes army. Fitted with a number of advanced weapons systems, from rapid fire autocannon to exotic beam weapons, there are few foes that can resist the firepower of a full squadron of these swift hunters. Once the foe is annihilated, the speed of these fleet vehicles allows them to evade any further counter-attack and reform to strike at the vulnerable flanks of the enemy, keeping the heavy armour suppressed as the Space Marine infantry advances to crush the foes of the Emperor.



THIS IS NOT A TOY

Not suitable for children under 15 years of age.

WARNING: Resin dust can be harmful if inhaled. Always wear a dust mask or respirator when sanding or sawing resin parts.



forge World®



Components

Before assembly, check that none of the components are missing.

1. Front Hull
2. Rear Hull
3. Lower Hull
4. Left Track Unit
5. Right Track Unit
6. Exhausts x2
7. Hatch
8. Main Weapon Brace
9. Secondary Weapon Turret
10. Right Rear Track Link
11. Left Rear Track Link
12. Left Sabre Missile Launchers x2
13. Right Sabre Missile Launchers x2
14. Volkite Culverin
15. Heavy Flamer
16. Heavy Bolter
17. Multi-melta

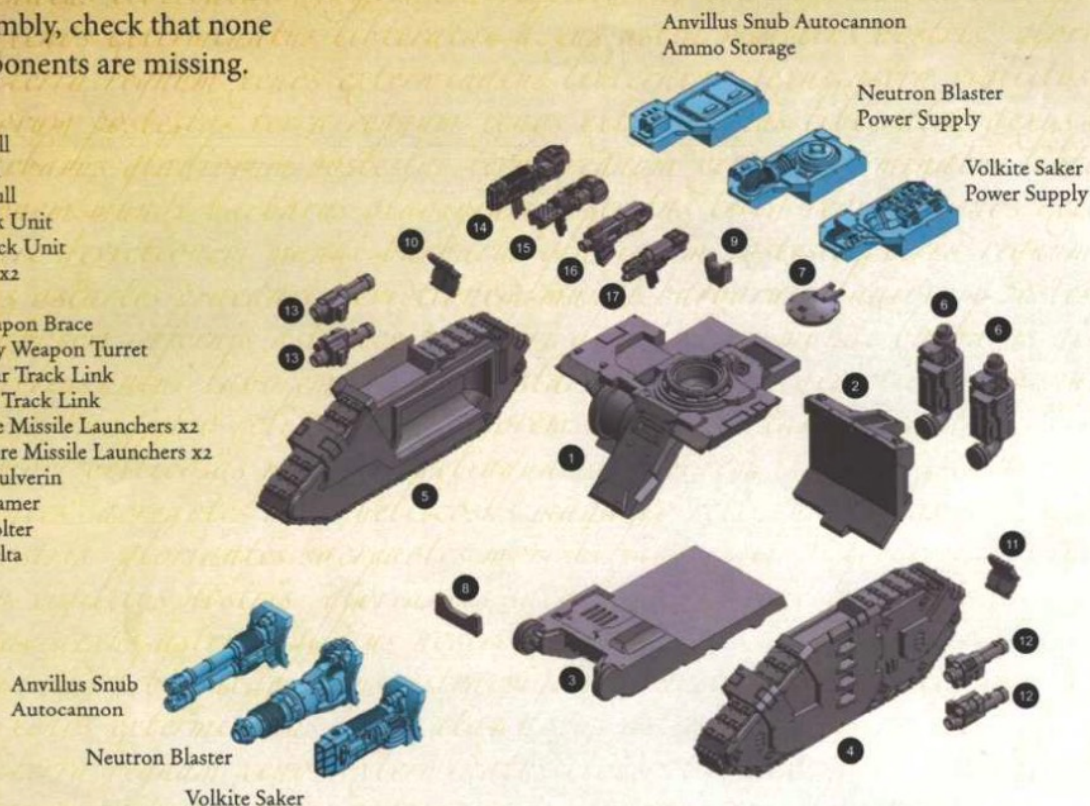

Assembly Legend

Parts for Assembly



Glue Contact Area



Optional Part



Additional Part (Not Included)



Shim For Removal



Note



Reverse Angle



Do Not Glue



Insert



Preparing the Model for Assembly

Before assembling the model, wash each part thoroughly with an abrasive brush, such as a toothbrush, to remove any model release agent that may still be on the surface of the parts. Then, remove any excess resin such as mould lines, casting gates, vents and shims. For a more detailed guide to working with resin models, go to the Downloads section of the Forge World website.

This kit contains all the pieces required to construct a Space Marine Legion Sabre Strike Tank. To glue the resin pieces together, use Citadel Super Glue.

NOTE: We have cast this kit using advanced techniques and the best quality resin, but due to the nature of the casting process, your model may contain small air bubbles. These can easily be filled with model filler or super glue. Any slight warpage of thin parts can easily be corrected by immersing the part in hot tap water for about 1 minute, then carefully bending it back into shape.

If you need to contact the Forge World Customer Service team regarding this model, you can get in touch via email - forgeworld@gwplc.com - or call:

0115 900 4995 within the UK

011 44 115 900 4995 from the USA and Canada

0011 44 115 900 4995 from Australia

00 44 115 900 4995 from Europe and the rest of the world.

I

1. Front Hull

2. Rear Hull

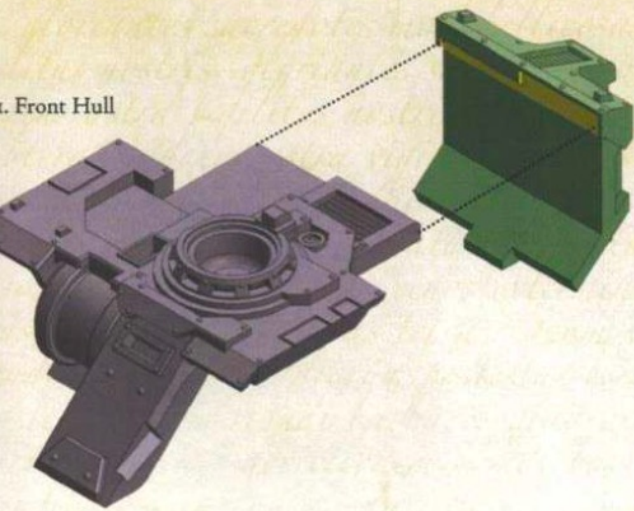

2

5. Right Track Unit

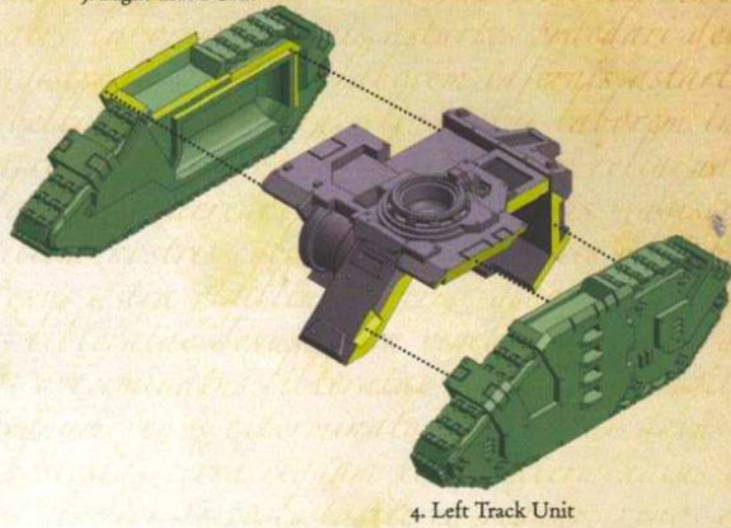

3

3. Lower Hull

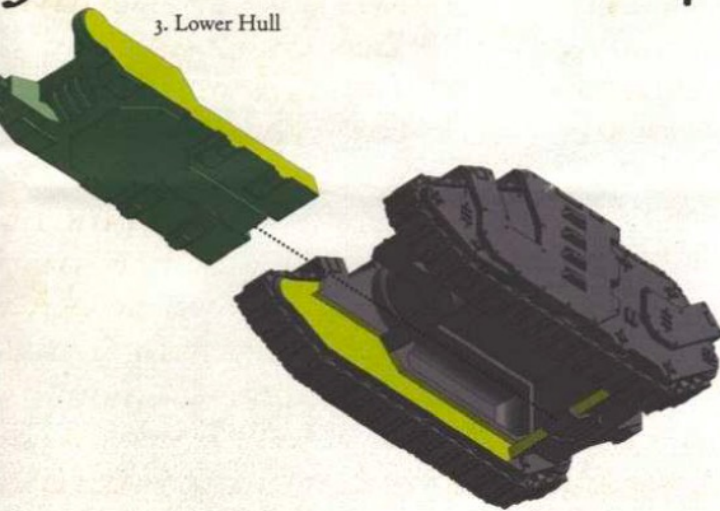

4

11. Left Rear Track Link

10. Right Rear Track Link



5

9. Secondary Weapon Turret

7. Hatch

8. Main Weapon Brace



6

13. Right Sabre Missile Launcher



7



12. Left Sabre
Missile Launcher

8

16. Heavy Bolter



9



The Sabre Strike Tank requires a main weapon option to be fitted (not included). The three sets featured here are the Anvillus Snub Autocannon, the Neutron Blaster and the Volkite Saker.



There are a number of secondary weapon options that can be fitted. Other options include 14. Volkite Culverin, 15. Heavy Flamer or 17. Multi-melta.



Anvillus Snub Autocannon
Ammo Storage

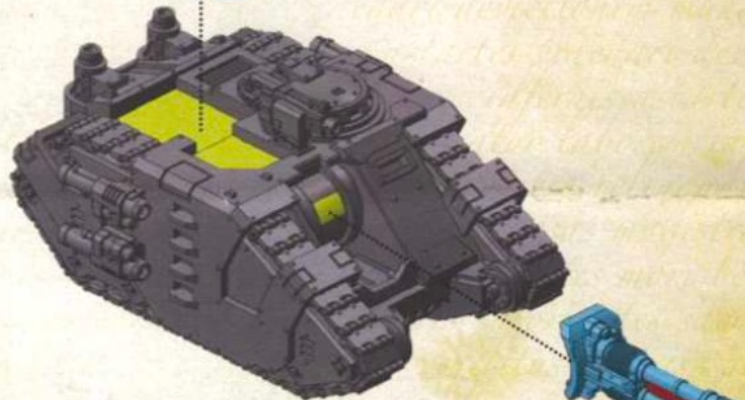

Anvillus Snub Autocannon

Neutron Blaster
Power Supply



Volkite Saker Power Supply



Neutron Blaster



Volkite Saker