



Free Downloads of Build Instructions,
Assembly Booklets & How To Guides

BuildInstructions.com

WARHAMMER
40.000

KILL TEAM

PATHFINDERS

CIBLEURS | RASTREADORES | SPÄHER | ESPLORATORI

ハスファインダー | 探路者

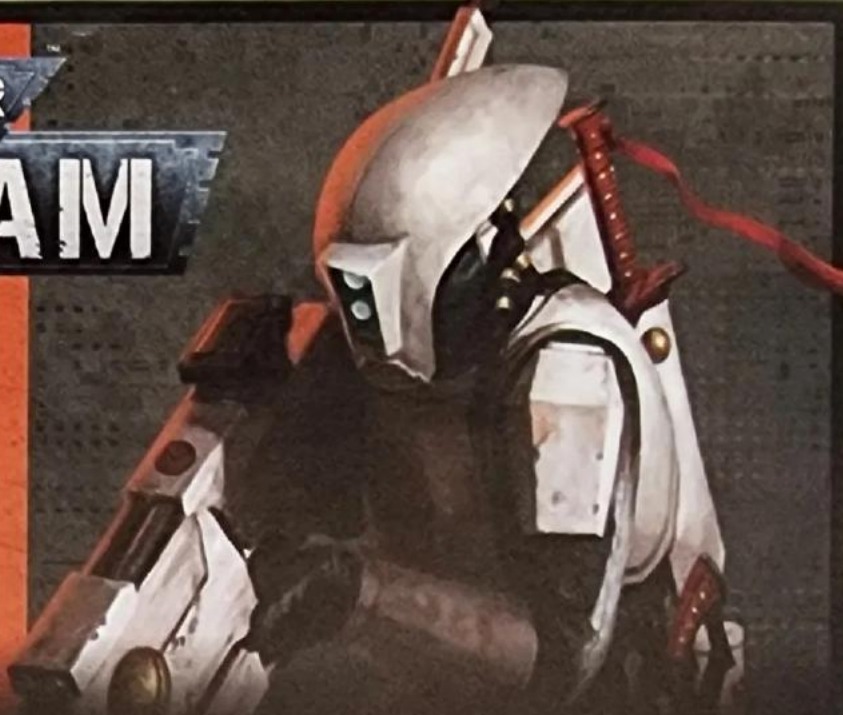

! READ THIS FIRST | À LIRE EN PRIORITÉ | BITTE BEACHTEN | LEE ESTO PRIMERO | LEGGI PRIMA QUESTO
最初にお読みください | 请优先阅读

ENG BEFORE ASSEMBLING YOUR MINIATURES, PLEASE READ THROUGH THE INSTRUCTIONS IN THIS BOOKLET CAREFULLY. A pair of plastic cutters is required to remove the plastic components in this kit from their frame. We advise using a mouldline scraping tool to clean up the parts. To assemble your model you will need plastic glue. Games Workshop sells Citadel Fine Detail Cutters, Citadel Mouldline Remover and Citadel Plastic Glue, but does not recommend these products for use by children under the age of 16 without adult supervision.

FRE AVANT D'ASSEMBLER VOS FIGURINES, VEUILLEZ LIRE ATTENTIVEMENT LES INSTRUCTIONS DE CE LIVRET. Une pince coupante est requise pour détacher chaque élément de sa grappe. Nous vous recommandons l'utilisation d'un grattoir pour ébarber les éléments. Pour l'assemblage, vous aurez également besoin de colle plastique. Games Workshop commercialise les Pinces de Précision Citadel, l'Ébarboir Citadel et la Colle Plastique Citadel, mais n'en recommande pas l'utilisation pour des enfants de moins de 16 ans sans la supervision d'un adulte.

ESP POR FAVOR, LEE CUIDADOSAMENTE ESTE LIBRETO DE INSTRUCCIONES ANTES DE EMPEZAR A MONTAR LAS MINIATURAS. Te harán falta unas tenazas para plástico a fin de separar las piezas de la matriz. También aconsejamos una herramienta para rebabas a fin de limpiar cada pieza. Para montar la miniatura necesitarás pegamento para plástico. Games Workshop vende Tenazas Citadel, Herramientas para rebabas Citadel y Pegamento para plástico Citadel, pero no recomienda estos productos a menores de 16 años sin la supervisión de un adulto.

GER VOR DEM ZUSAMMENBAU DER MINIATUREN BITTE DIE ANWEISUNGEN IN DIESER ANLEITUNG AUFMERKSAM DURCHLESEN. Du benötigst einen Kunststoffseitenschneider, um die Kunststoffbauteile aus dem Gussrahmen herauszutrennen, und Kunststoffkleber, um die Miniatur zusammenzubauen. Außerdem empfehlen wir, die Bauteile vorher mit einem Gussgratentferner zu säubern. Games Workshop bietet Präzisions-Kunststoffseitenschneider von Citadel sowie Citadel-Kunststoffkleber an, empfiehlt aber, dass Kinder unter 16 Jahren diese nur unter Aufsicht eines Erwachsenen benutzen.

ITA PRIMA DI ASSEMBLARE LE TUE MINIATURE LEGGI ATTENTAMENTE TUTTE LE ISTRUZIONI DI QUESTO LIBRETTO. Sono necessarie un paio di tronchesine per plastica per staccare i componenti dai loro sprue. Consigliamo di usare un attrezzo apposito per pulire i componenti. Per assemblare il modello avrai bisogno di colla per plastica. Games Workshop vende Tronchesine di precisione Citadel. Attrezzo per ripulire Citadel e Colla per plastica Citadel, ma non consiglia questi prodotti ad un pubblico minore di 16 anni senza la supervisione di un adulto.

日本語 本キット内のフレームからプラスチックパーツを切り離すためには、ニッパーが必要です。パーツのモールドを平らにするには、専用ツールを使用をお勧めいたします。本キットの組み立てには、プラ用接着剤が必要です。ゲームワークショップはシタデル・ニッパー、プラ用接着剤、シタデル・モールドラインリムーバーを販売しておりますが、16歳以下の子供が大人の監督なしにこれらの道具を使用されることをお勧めしません。

中文 你需要一把模型剪将塑料部件从版板上剪下来。我们建议使用分模线刮刀来处理零件。组装时你还需要用到模型胶水。你可以从 Games Workshop 处购买到 Citadel Fine Detail Cutter 模型剪、Citadel Mouldline Remover 分模线刮刀和 Citadel Plastic Glue 模型胶。但 16 岁以下儿童不得在没有成年人监护的情况下使用这些产品。

EXPLANATION OF SYMBOLS | EXPLICATION DES SYMBOLES | EXPLICACIÓN DE SÍMBOLOS
ERLÄUTERUNG DER SYMBOLE | LEGENDA DEI SIMBOLI | アイコン解説 | 符号说明

-  Variant assembly
- Variante d'assemblage
- Variante de montaje
- Bauvariante
- Assemblaggio alternativo
- 組み立てバリエーション
- 多种组装方式

-  Choice of parts
- Choix d'éléments
- Modelos de componentes
- Auswahl an Teilen
- Scelta di componenti
- パーツの選択
- 选择部件

-  Repeat process
- Répéter l'étape
- Repetir pasos
- Vorgang wiederholen
- Ripeti il processo
- 同じ作業を繰り返すこと
- 重复步骤

-  Use matching parts
- Utiliser les éléments correspondants

-  Do not glue the components
- Ne pas coller les éléments

-  Stage complete
- Étape terminée

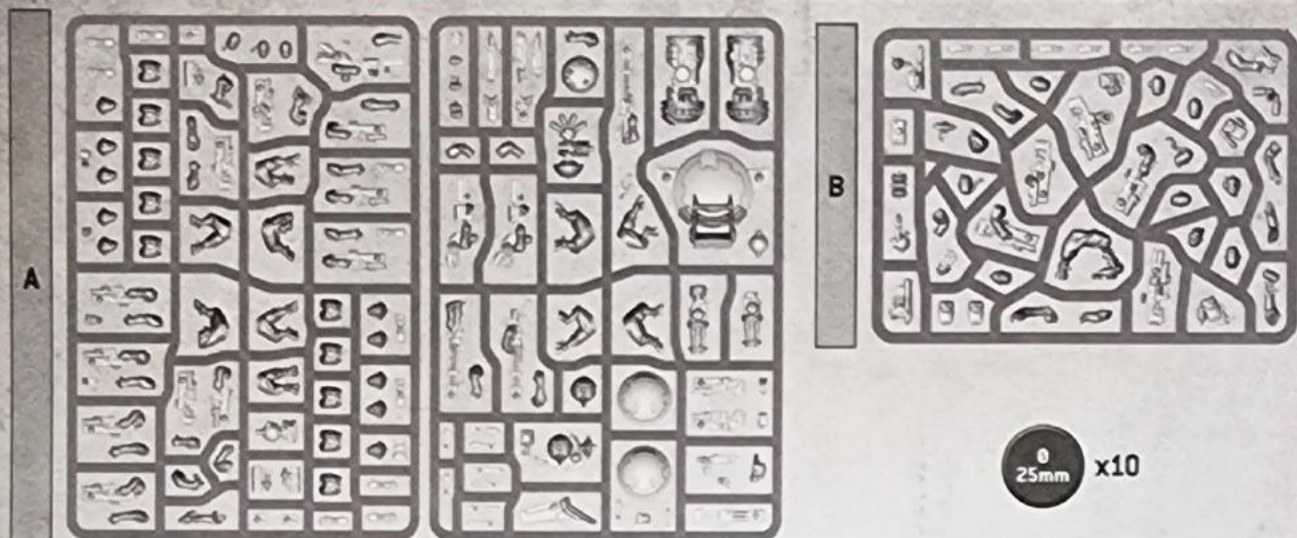

BUILD VARIANTS | VARIANTES D'ASSEMBLAGE | VARIANTES DE MONTAJE | BAUVARIANTEN
VARIANTI D'ASSEMBLAGGIO | バリエーション | 变体版

- Assemblies for build variants are colour coded.
- Les assemblages de variantes ont un code couleur.
- Las instrucciones para montajes alternativos se indican con un color diferente.
- Optionen für Bauvarianten sind farblich markiert.
- Le diverse varianti d'assemblaggio sono divise per colore.
- バリエーション違いの組み立ては色分けされている。
- 变体版拼装部件有颜色区分。



PATHFINDER KILL TEAM

KILL TEAM DE CIBLEURS | COMANDO RASTREADOR | SPÄHER-KILL-TEAM | KILL TEAM ESPLORATORI
 バスファインダー・キルチーム | 探路者杀戮小队

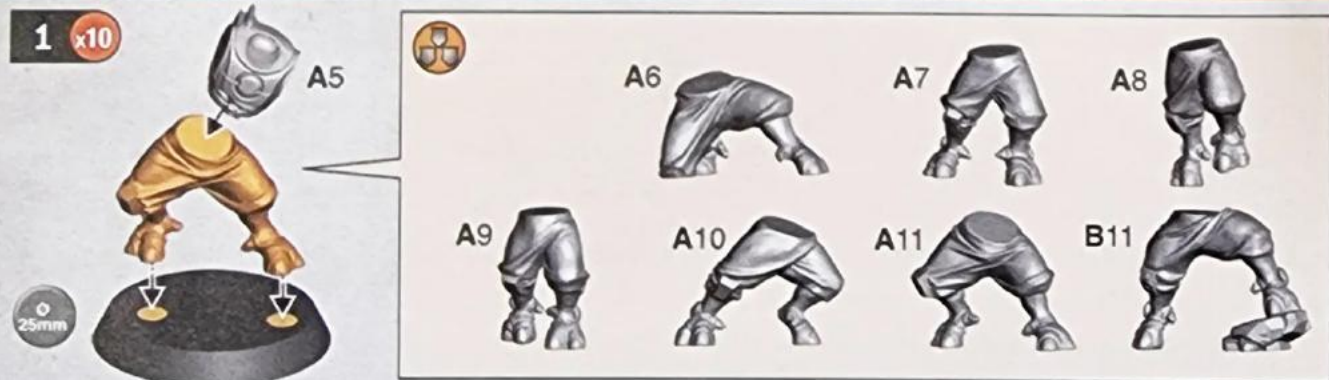

2 a

Shas'ui Pathfinder
 Shas'ui Cibleur
 Rastreador Shas'ui
 Späher-Shas'ui
 Esploratore Shas'ui
 シャス=ウィ・パスファインダー
 火氏老兵探路者



2 b

Shas'ui Pathfinder
 Shas'ui Cibleur
 Rastreador Shas'ui
 Späher-Shas'ui
 Esploratore Shas'ui
 シャス=ウィ・パスファインダー
 火氏老兵探路者



2 a

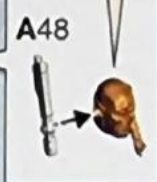

2 b

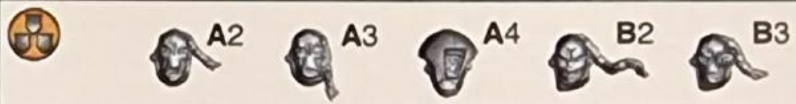
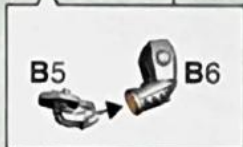

3 a

Shas'la Pathfinder • Shas'la Cibleur • Rastreador Shas'la • Späher-Shas'la • Exploratore Shas'la
 シャス=ラ・パスファインダー • 火氏战士探路者

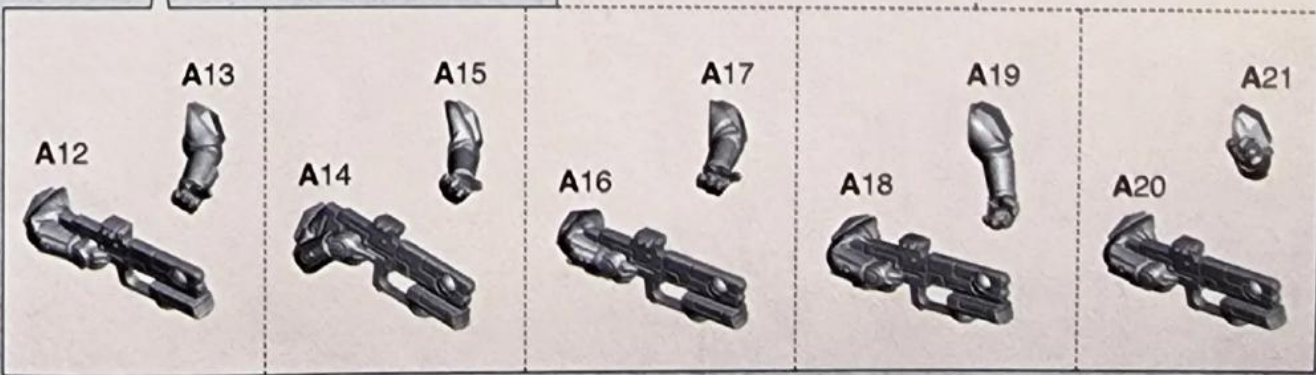
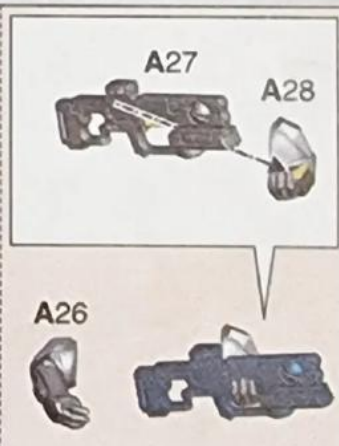
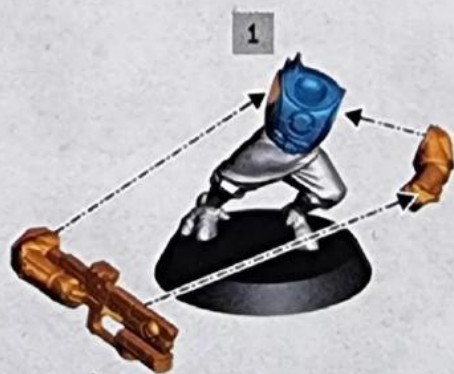

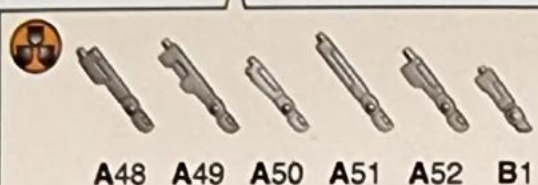
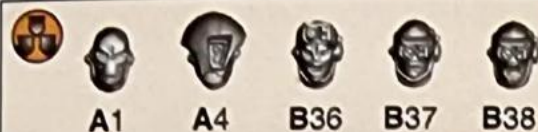
3 b

4 Communications Specialist Pathfinder • Cibleur Spécialiste des Transmissions
 Rastreador Especialista en Comunicaciones • Späher-Kommunikationsspezialist • Esploratore Specialista delle Comunicazioni
 コミュニケーション・スペシャリスト・パスファインダー • 通讯专家探路者

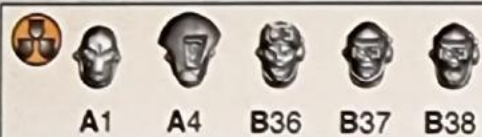

5 a Marksman Pathfinder • Cibleur Sniper • Rastreador Tirador • Späher-Scharfschütze • Esploratore Tiratore Scelto
 マークスマン・パスファインダー • 神射手探路者

**5 b**

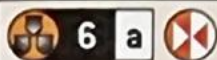

A30



A29



A42



A36



A35

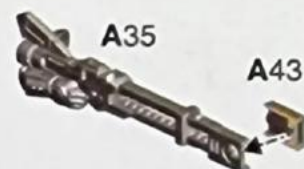

A43

A32



A31



A42

A38



A37



A43

A34



A33



A42

A40

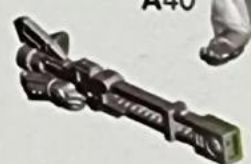

A39



A43

6 b

6 a



A1



A4



B36



B37



B38



A48



A49



A50



A51



A52

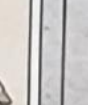

B1



7

Blooded Pathfinder • Cibleur Valeureux • Rastreador Aguerrido • Erfahrener Späher • Esploratore Insanguinato
 ブラッデッド・パスファインダー • 血色探路者

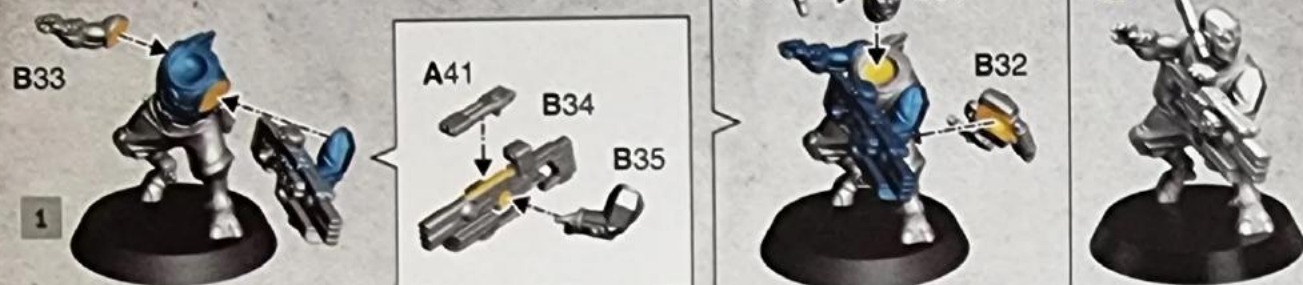

8

Drone Controller Pathfinder • Cibleur Contrôleur de Drones • Rastreador Controlador de Drones • Späher mit Drohnensteuerung
 Esploratore Pilota di Droni • ドローンコントローラー・パスファインダー • 无人机控制器探路者

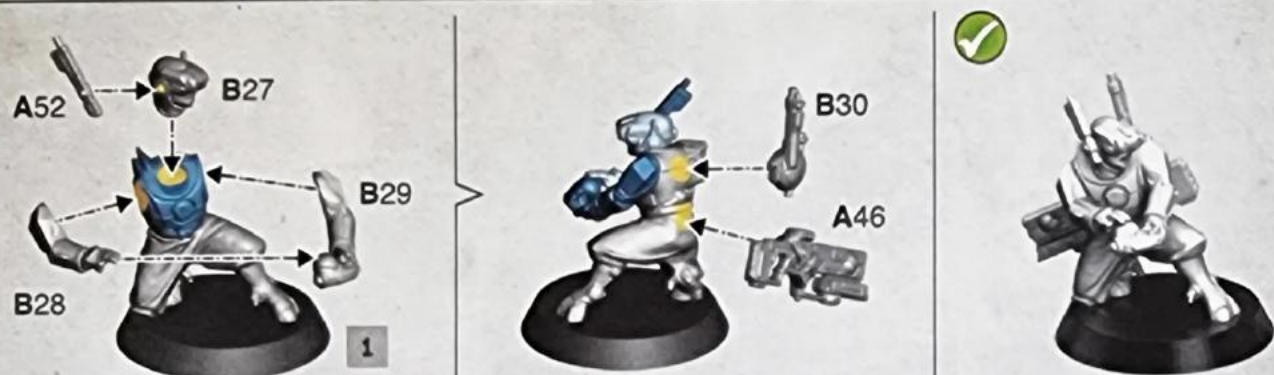

9

Assault Grenadier Pathfinder • Cibleur Grenadier d'Assaut • Rastreador Granadero de Asalto • Späher-Sturmgranadier
 Esploratore Granatiere d'Assalto • アサルトグレネーディア・パスファインダー • 突撃掷弹兵探路者

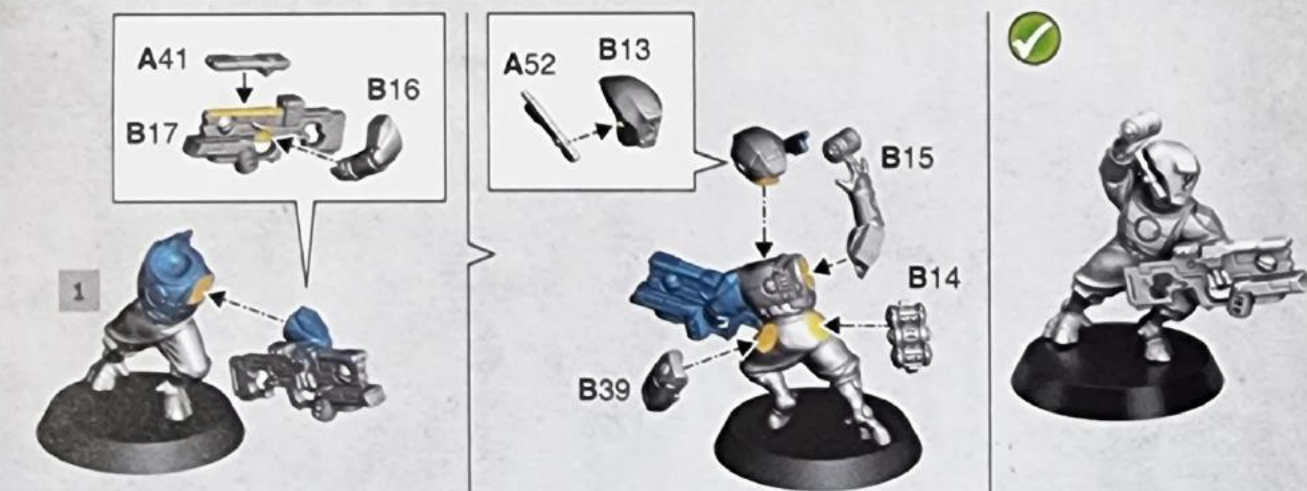

10 Medical Technician Pathfinder • Cibleur Technicien Médical • Rastreador Técnico Sanitario • Medizintechnischer Späher
 Esploratore Meditecnico • メディカルテクニシャン・パスファインダー • 医疗技师探路者

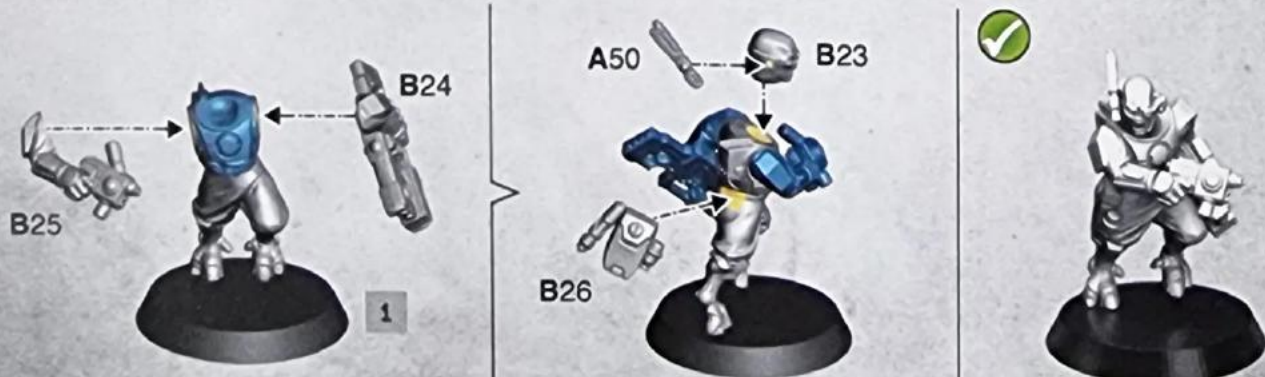

11

Transpectral Interference Pathfinder • Cibleur Brouilleur Transpectral • Rastreador Interferidor Transpectral • Transspektralinterferenz-Späher
 Esploratore Disturbatore Transpettrale • トランススペクトラル・インターフェレンス・パスファインダー • 超光谱干扰探路者



12

2-11



13

MB3 Recon Drone • Drone de Reconnaissance MB3 • Dron de Reconocimiento MB3 • MB3-Aufklärungsdrohne • Drone da Ricognizione MB3
 MB3 レコン・ドローン • MB3 侦察无人机

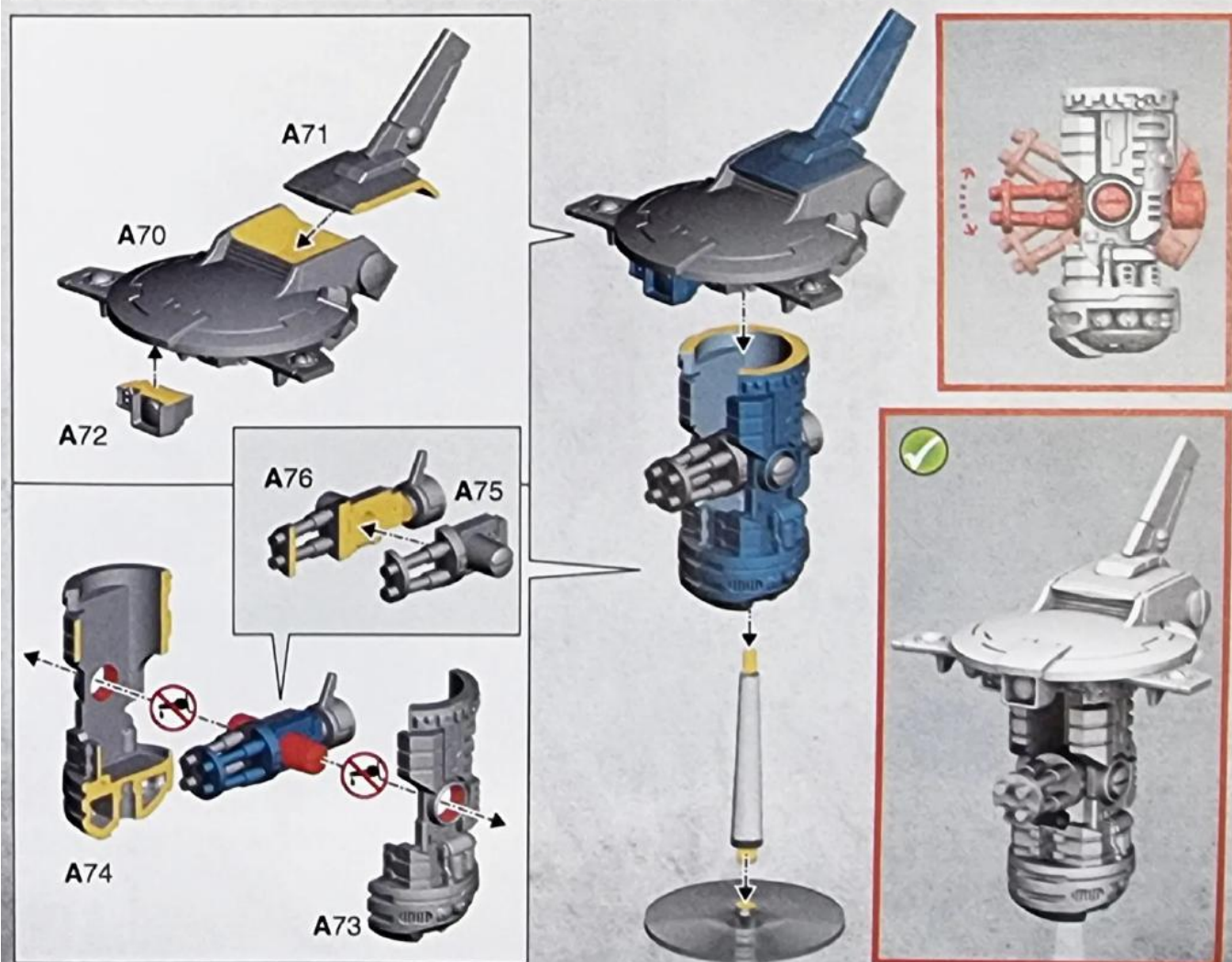



MV33 Grav-Inhibitor Drone
 Drone Inhibiteur MV33
 Dron AntiGravedad MV33
 MV33-Gravinhbitordrohne
 Drone Inibitore Grav MV33
 MV33 グラヴィンヒビター・ドローン
 MV33 重力抑制無人機



MV31 Pulse Accelerator Drone
 Drone Impulseur MV31
 Dron Acelerador de Inducción MV31
 MV31-Pulsbeschleunigerdrohne
 Drone Acceleratore di Impulsi MV31
 MV31 パルスアクセラレータ・ドローン
 MV31 脉冲加速無人機



MV1 Gun Drone
 Drone Armé MV1
 Dron de combat MV1
 MV1-Angriffsdrohne
 Drone Arma MV1
 MV1 ガン・ドローン
 MV1 火炮無人機



MV7 Marker Drone
 Drone de Marquage MV7
 Dron telemétrico MV7
 MV7-Markiererdrohne
 Drone Tracclatore MV7
 MV7 マーカー・ドローン
 MV7 标记無人機



MV4 Shield Drone
 Drone Bouclier MV4
 Dron de defensa MV4
 MV4-Schilddrohne
 Drone Scudo MV4
 MV4 シールド・ドローン
 MV4 护盾無人機

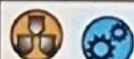

warhammer.com

Games Workshop Limited, Willow Road,
 Nottingham, NG7 2WS, UK

© Copyright Games Workshop Limited 2022

