



Free Downloads of Build Instructions,
Assembly Booklets & How To Guides

BuildInstructions.com

WARHAMMER
40,000

FEIRROS





• READ THIS FIRST • À LIRE EN PREMIER • LEER ANTES DE MONTAR
• LIES DIES ZUERST • LEGGI PRIMA QUESTO

- BEFORE ASSEMBLING YOUR MINIATURES PLEASE READ THROUGH THE INSTRUCTIONS IN THIS BOOKLET CAREFULLY. A pair of plastic cutters is required to remove the plastic components in this kit from their frame. We advise using a mouldline scraping tool to clean up the parts. To assemble your model you will need plastic glue. Games Workshop sells Citadel Fine Detail Cutters, Citadel Mouldline Remover and Citadel Plastic Glue, but does not recommend these products for use by children under the age of 16 without adult supervision.
- AVANT D'ASSEMBLER VOS FIGURINES, VEUILLEZ LIRE ATTENTIVEMENT LES INSTRUCTIONS DE CE LIVRET. Une pince coupante est requise pour détacher chaque élément de sa grappe. Nous vous recommandons l'utilisation d'un grattoir pour ébarber les éléments. Pour l'assemblage, vous aurez également besoin de colle plastique. Games Workshop commercialise les Pinces de Précision Citadel, l'Ébarboir Citadel et la Colle Plastique Citadel, mais n'en recommande pas l'utilisation pour des enfants de moins de 16 ans sans la supervision d'un adulte.
- POR FAVOR, LEE CUIDADOSAMENTE ESTE LIBRETO DE INSTRUCCIONES ANTES DE EMPEZAR A MONTAR LAS MINIATURAS. Te harán falta unas tenazas para plástico a fin de separar las piezas de la matriz. También aconsejamos una herramienta para rebabas a fin de limpiar cada pieza. Para montar la miniatura necesitarás pegamento para plástico. Games Workshop vende Tenazas Citadel, Herramientas para rebabas Citadel y Pegamento para plástico Citadel, pero no recomienda estos productos a menores de 16 años sin la supervisión de un adulto.
- VOR DEM ZUSAMMENBAU DER MINIATUREN BITTE DIE ANWEISUNGEN IN DIESER ANLEITUNG AUFMERKSAM DURCHLESEN. Du benötigst einen Kunststoffseitenschneider, um die Kunststoffbauteile aus dem Gussrahmen herauszutrennen, und Kunststoffkleber, um die Miniatur zusammenzubauen. Außerdem empfehlen wir, die Bauteile vorher mit einem Gussgratentferner zu säubern. Games Workshop bietet Präzisions-Kunststoffseitenschneider von Citadel sowie Citadel-Kunststoffkleber an, empfiehlt aber, dass Kinder unter 16 Jahren diese nur unter Aufsicht eines Erwachsenen benutzen.
- PRIMA DI ASSEMBLARE LE TUE MINIATURE LEGGI ATTENTAMENTE TUTTE LE ISTRUZIONI DI QUESTO LIBRETTO. Sono necessarie un paio di tronchesine per plastica per staccare i componenti dai loro sprue. Consigliamo di usare un attrezzo apposito per pulire i componenti. Per assemblare il modello avrai bisogno di colla per plastica. Games Workshop vende Tronchesine di precisione Citadel, Attrezzo per ripulire Citadel e Colla per plastica Citadel, ma non consiglia questi prodotti ad un pubblico minore di 16 anni senza la supervisione di un adulto.

• EXPLANATION OF SYMBOLS • EXPLICATION DES SYMBOLES • EXPLICACIÓN DE SÍMBOLOS
• ERLÄUTERUNG DER SYMBOLE • LEGENDA DEI SIMBOLI



- Stage complete
- Étape terminée
- Paso completado
- Schritt abgeschlossen
- Fase completa



- Dry fit stage before gluing
- Tester avant de coller
- Comprobar el encaje antes de pegar
- Positionierung erst ohne Klebstoff ausprobieren
- Prova a secco prima di incollare

1

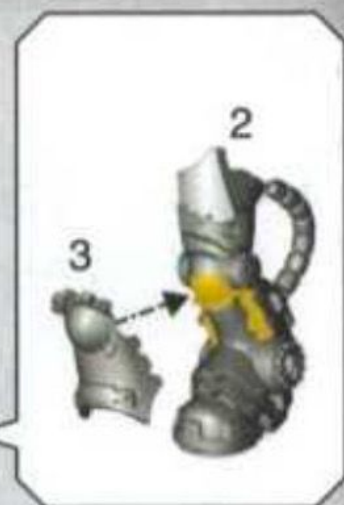

2



- Harrowhand
- Hersemain
- Mano atormentada
- Hand der Verwüstung
- Mano del Supplizio

3



4



5

14

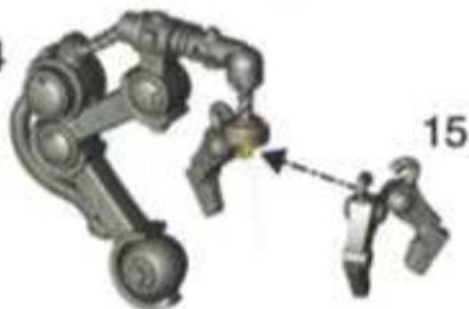

15

• Servo-arm • Servobras • Servobrazo
• Servoarm • Servobraccio



4



12

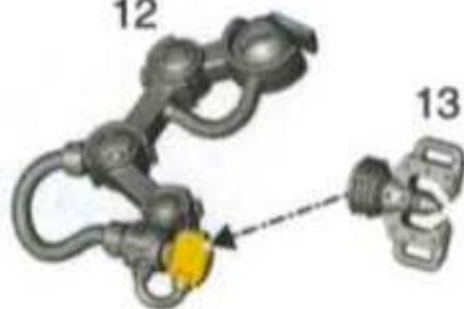

13



6

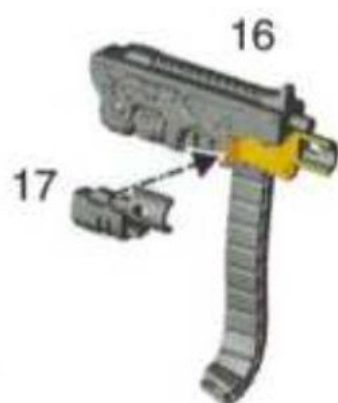

- Gorgon's Wrath
- Ire de la Gorgone
- Ira de Gorgon
- Zorn des Gorgonen
- Ira della Gorgone

5

7



6

Ø
40mm



BASE GREY SEER
SHADE DRAKENHOF NIGHTSHADE
LAYER WHITE SCAR

BASE RAKARTH FLESH
SHADE REIKLAND FLESHSHADE
LAYER PALLID WYCH FLESH
LAYER WHITE SCAR

BASE LEADBELCHER
SHADE NULN OIL
LAYER IRONBREAKER
LAYER STORMHOST SILVER

IRON FATHER FEIRROS

6
POINTS

NAME	M	WS	BS	S	T	W	A	Ld	Sv
Iron Father Feirros	5"	3+	2+	4	5	7	5	9	2+

Iron Father Feirros is a single model equipped with: bolt pistol; Gorgon's Wrath; Harrowhand; 2 servo-arms. You can only include one of this model in your army.

WEAPONS	RANGE	TYPE	S	AP	D	ABILITIES
Bolt pistol	12"	Pistol 1	4	0	1	-
Gorgon's Wrath	36"	Heavy 3	5	-2	2	-
Harrowhand	Melee	Melee	+3	-2	2	-
Servo-arm	Melee	Melee	x2	-2	3	When the bearer fights, no more than one attack can be made with each servo-arm. When resolving an attack made with this weapon, subtract 1 from the hit roll.

ABILITIES

Angels of Death

Artificer Bionics: When this model would lose a wound, roll one D6; on a 5+ that wound is not lost.

Blessing of the Omnissiah: At the end of your Movement phase, this model can repair one friendly **IRON HANDS VEHICLE** model within 1" of it. That model regains D3 lost wounds. Each model can only be repaired once per turn.

Signum Array: At the start of your Shooting phase, you can select one friendly **IRON HANDS** unit that is within 3" of this model. Models in the selected unit have a Ballistic Skill characteristic of 2+ until the end of that phase.

Rites of Tempering: Models in friendly **IRON HANDS** units have a 5+ invulnerable save whilst their unit is within 6" of this model.

Master of the Forge: When this model repairs a **VEHICLE** model using its Blessing of the Omnissiah ability, that **VEHICLE** model regains up to 3 lost wounds instead of up to D3.

FACTION KEYWORDS

IMPERIUM, ADEPTUS ASTARTES, IRON HANDS

KEYWORDS

CHARACTER, INFANTRY, MK X GRAVIS, PRIMARIS, IRON FATHER, MASTER OF THE FORGE, TECHMARINE, FEIRROS

IRON FATHER FEIRROS



NOM	M	CC	CT	F	E	PV	A	Cd	Sv
Iron Father Feirros	5"	3+	2+	4	5	7	5	9	2+

Iron Father Feirros est une figurine individuelle équipée de : pistolet bolter ; Ire de la Gorgone ; Hersemain ; 2 servobras. Vous ne pouvez inclure cette figurine à votre armée qu'un un seul exemplaire.

ARMES	PORTÉE	TYPE	F	PA	D	APTITUDES
Pistolet bolter	12"	Pistolet 1	4	0	1	-
Ire de la Gorgone	36"	Lourde 3	5	-2	2	-
Hersemain	Mêlée	Mêlée	+3	-2	2	-
Servobras	Mêlée	Mêlée	x2	-2	3	Quand le porteur combat, chaque servobras ne peut effectuer qu'une seule attaque maximum. Quand vous résolvez une attaque avec cette arme, soustrayez 1 au jet de touche.

APTITUDES

Anges de la Mort

Bioniques d'Artificier : Quand cette figurine va perdre un PV, jetez 1 D6 ; sur 5+, elle ne le perd pas.

Bénédictio de l'Omnimesse : À la fin de votre phase de Mouvement, cette figurine peut réparer 1 figurine **VÉHICULE IRON HANDS** amie à 1" ou moins d'elle. La figurine réparée récupère D3 PV perdus. Chaque figurine ne peut être réparée qu'une seule fois par tour.

Panoplie Signum : Au début de votre phase de Tir, vous pouvez choisir 1 unité **IRON HANDS** amie à 3" ou moins de cette figurine. Les figurines de l'unité choisie ont une caractéristique de CT de 2+ jusqu'à la fin de la phase.

Rites de Trempe : Les figurines des unité **IRON HANDS** amies ont une sauvegarde invulnérable de 5+ tant que leur unité est à 6" ou moins de cette figurine.

Maître de la Forge : Quand cette figurine répare une figurine **VÉHICULE** grâce à son aptitude Bénédictio de l'Omnimesse, la figurine **VÉHICULE** concernée récupère jusqu'à 3 PV perdus au lieu de D3.

MOTS-CLÉS DE FACTION

IMPERIUM, ADEPTUS ASTARTES, IRON HANDS

MOTS-CLÉS

PERSONNAGE, INFANTERIE, MK X GRAVIS, PRIMARIS, IRON FATHER, MAÎTRE DE LA FORGE, TECHMARINE, FEIRROS