



Free Downloads of Build Instructions,  
Assembly Booklets & How To Guides

**BuildInstructions.com**

# HEKATON LAND FORTRESS

FORTEBASTION MOBILE HEKATON | TERRABASTIÓN HEKATON | HEKATON-LANDFESTUNG | FORTEZZA SEMOVENTE HEKATON | Мобильная Крепость Гекатон | ヘカトン・ランドフォートレス | 赫卡頓陸行要塞



**READ THIS FIRST | À LIRE EN PRIORITÉ | BITTE BEACHTEN | LEE ESTO PRIMERO | LEGGI PRIMA QUESTO | В ПЕРВУЮ ОЧЕРЕДЬ ПРОЧИТАЙТЕ ЭТО**  
**最初にお読みください。 | 请优先阅读**

**BEFORE ASSEMBLING YOUR MINIATURES, PLEASE READ THROUGH THE INSTRUCTIONS IN THIS BOOKLET CAREFULLY.** A pair of plastic cutters is required to remove the plastic components in this kit from their frame. We advise using a mouldline scraper to clean up the parts. To assemble your model you will need plastic glue. Games Workshop sells Citadel Fine Detail Cutters, Citadel Mouldline Remover and Citadel Plastic Glue, but does not recommend these products for use by children under the age of 16 without adult supervision.

**AVANT D'ASSEMBLER VOS FIGURINES, VEUILLEZ LIRE ATTENTIVEMENT LES INSTRUCTIONS DE CE LIVRET.** Une pince coupante est requise pour détacher chaque élément de sa grappe. Nous vous recommandons l'utilisation d'un grattoir pour ébarber les éléments. Pour l'assemblage, vous aurez également besoin de colle plastique. Games Workshop commercialise les produits de Précision Citadel, l'Ébarboir Citadel et la Colle Plastique Citadel, mais n'en recommande l'utilisation pour des enfants de moins de 16 ans sans la supervision d'un adulte.

**POR FAVOR, LEE CUIDADOSAMENTE ESTE LIBRETO DE INSTRUCCIONES ANTES DE EMPEZAR A MONTAR LAS MINIATURAS.** Te harán falta unas tenazas para plástico a fin de arrancar las piezas de la matriz. También aconsejamos una herramienta para rebabas a fin de limpiar cada pieza. Para montar la miniatura necesitarás pegamento para plástico. Games Workshop vende las tijeras Citadel, Herramientas para rebabas Citadel y Pegamento para plástico Citadel, pero no recomienda estos productos a menores de 16 años sin la supervisión de un adulto.

**VOR DEM ZUSAMMENBAU DER MINIATUREN BITTE DIE ANWEISUNGEN IN DIESEM ANLEITUNG AUFMERKSAM DURCHLESEN.** Du benötigst einen Kunststoffseitschneider, um die Kunststoffbauteile aus dem Gussrahmen herauszutrennen, einen Kunststoffkleber, um die Miniatur zusammenzubauen. Außerdem empfehlen wir, die Bauteile vorher mit einem Gussgratentferner zu säubern. Games Workshop bietet Präzisions-Kunststoffseitschneider von Citadel sowie Citadel-Kunststoffkleber an, empfiehlt aber, dass Kinder unter 16 Jahren diese nur unter Aufsicht eines Erwachsenen benutzen.

**PRIMA DI ASSEMBLARE LE TUE MINIATURE LEGGI TUTTE LE ISTRUZIONI DI QUESTO LIBRETTO.** Sono necessarie un paio di tronchesine per plastica per staccare i componenti dai loro sprue. Consigliamo l'uso di uno strumento apposito per pulire i componenti. Per assemblare il modello avrai anche bisogno di colla per plastica. Games Workshop vende Tronchesine di precisione Citadel, Colla per plastica Citadel e Colla per plastica Citadel, ma non consiglia questi prodotti per un pubblico minore di 16 anni senza la supervisione di un adulto.

**Кусачки для пластика нужны для снятия пластиковых элементов с рамок. Для зачистки деталей рекомендуем использовать инструмент с наждачной бумагой. Для сборки модели вам понадобятся клей для пластика. Games Workshop предоставляет кусачки «Citadel Fine Detail Cutters», инструмент Citadel Mouldline Remover и клей для пластика Citadel Plastic Glue, но не рекомендует эти изделия к использованию детьми младше 16 лет без надзора взрослых.**

**本キット内のフレームからプラスチックパーツを切り離すために専用工具の使用が必要です。パーツのモールドを平らにするには、専用ツールを使用してください。本キットの組み立てには、プラ用接着剤が必要です。ゲームズワークショップの Citadel・ニッパー、プラ用接着剤、シタデル・モールドラインリムーバーがおすすめです。16歳以下の子供が大人の監督なしにこれらの道具を使用しないでください。**

**你需要一把模型剪将塑料部件从板件上剪下来。我们建议使用 Citadel 分模线刮刀 Citadel Mouldline Remover 分模线刮刀 Citadel Plastic Glue 模型胶，但 16 岁以下儿童不得在没有成年人监护的情况下使用。**

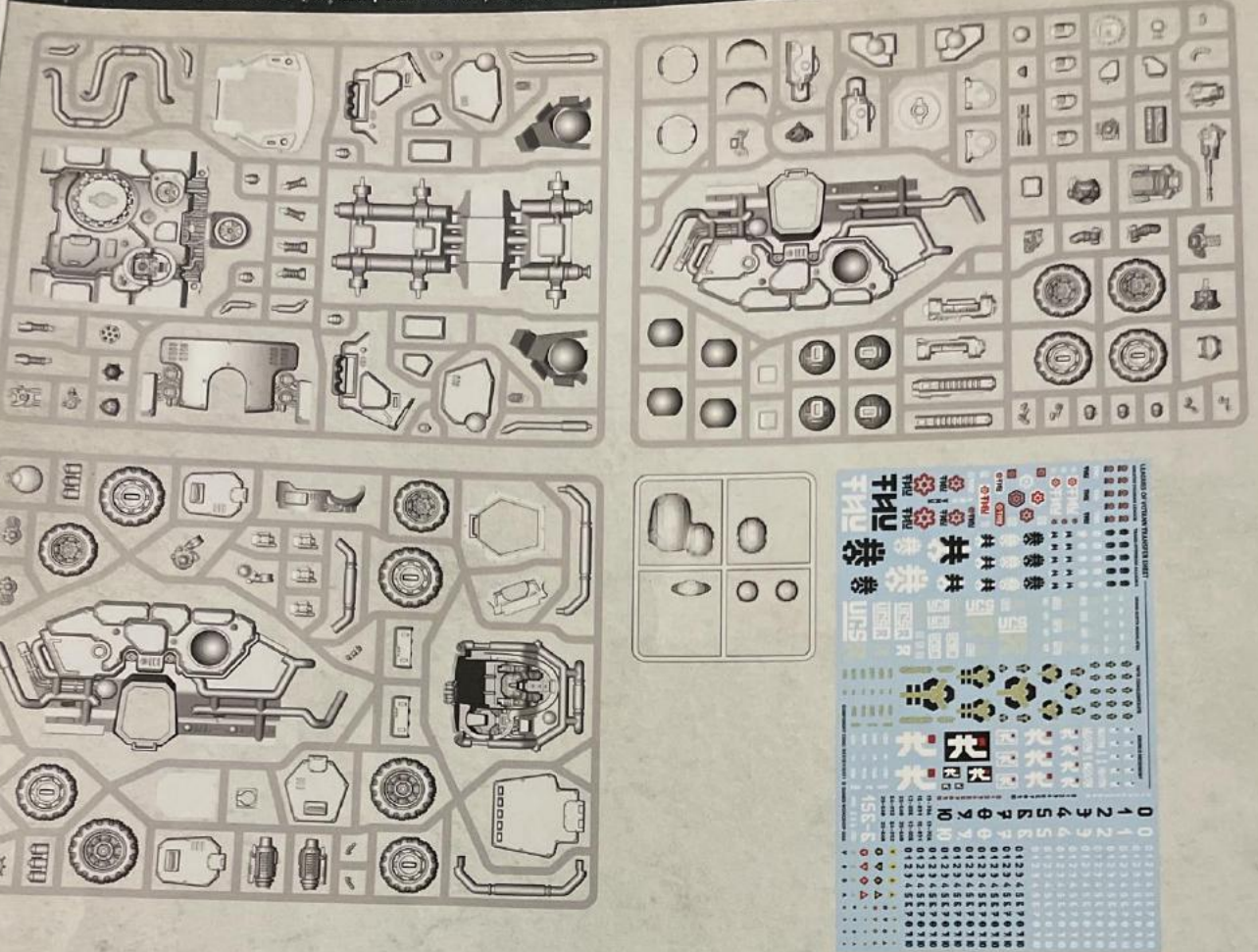

**BUILD VARIANTS | VARIANTES D'ASSEMBLAGE | VARIANTES DE MONTAJE | BAUVARIANTEN | VARIANTI D'ASSEMBLAGGIO | ВАРИАНТЫ СБОРКИ**  
 バリエーション | 変体版

- Assemblies for build variants are colour coded.
  - Les assemblages de variantes ont un code couleur.
  - Las instrucciones para montajes alternativos se indican con un color diferente.
  - Optionen für Bauvarianten sind farblich markiert.
  - Le diverse varianti d'assemblaggio sono divise per colore.
  - Различные варианты сборки выделены разными цветами.
  - バリエーション違いの組み立ては色分けされている。
- 変体版拼装部件有颜色区分



**EXPLANATION OF SYMBOLS | EXPLICATION DES SYMBOLES | EXPLICACIÓN DE SÍMBOLOS | ERLÄUTERUNG DER SYMBOLE | LEGENDA DEI SIMBOLI**  
 СИМВОЛЫ | アイコン解説 | 符号说明

Special instruction - take care  
 Instruction spéciale - faites attention  
 Instrucciones especiales - presta atención  
 Besondere Anweisung - bitte beachten  
 Istruzioni speciali: prestare attenzione  
 Особая инструкция - Будьте осторожны  
 特記事項 - 要注意  
 特別説明 - 小心

Do not glue the components  
 Ne pas coller les éléments  
 No pegar los componentes  
 Die Teile nicht kleben  
 Non incollare i componenti  
 Не склеивайте детали  
 このステップは接着不可

- Variant assembly  
 • Variante d'assemblage  
 • Variante de montaje  
 • Bauvariante  
 • Assemblaggio alternativo  
 • Варианты сборки  
 • 組み立てバリエーション  
 • 多种组装方式
- Paint before assembly  
 • Peindre avant assemblage  
 • Pintar antes del montaje  
 • Erst bemalen, dann zusammenbauen  
 • Dipinti prima dell'assemblaggio  
 • Покрасьте перед сборкой  
 • 組み立て前にペイントすること
- Choice of parts  
 • Choix d'éléments  
 • Modelos de componentes  
 • Auswahl an Teilen  
 • Scelta di componenti  
 • Выбор деталей  
 • パーツの選択  
 • 选择部件
- Assembly sequence  
 • Séquence d'Assemblage  
 • Secuencia de montaje  
 • Baureihenfolge  
 • Sequenza di assemblaggio  
 • Последовательность сборки  
 • 組み立て手順  
 • 拼装顺序
- Repeat process  
 • Répéter l'étape  
 • Repetir pasos  
 • Vorgang wiederholen  
 • Ripeti il processo  
 • Повторите действие  
 • 同じ作業を繰り返すこと  
 • 重复步骤
- Stage complete  
 • Étape terminée  
 • Paso completado  
 • Schritt abgeschlossen  
 • Fase completa  
 • Этап завершён  
 • このステップの完成  
 • 完成

1 a

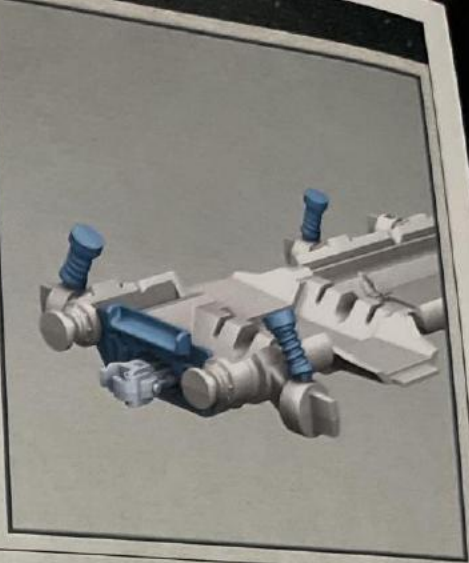
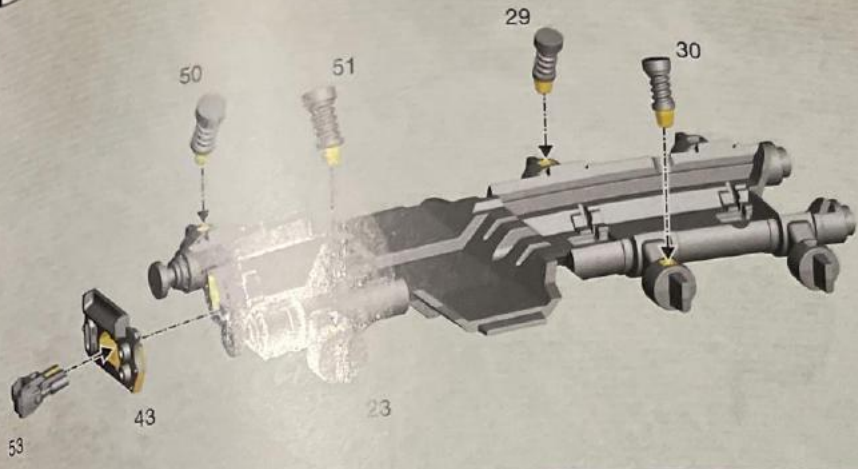

1 b

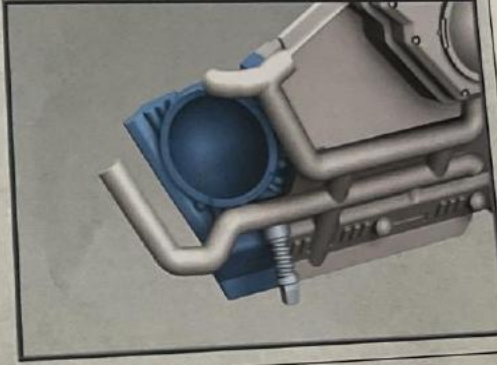
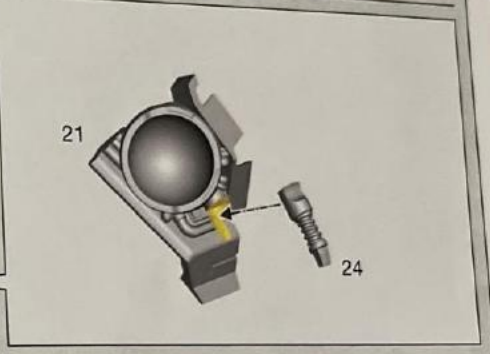
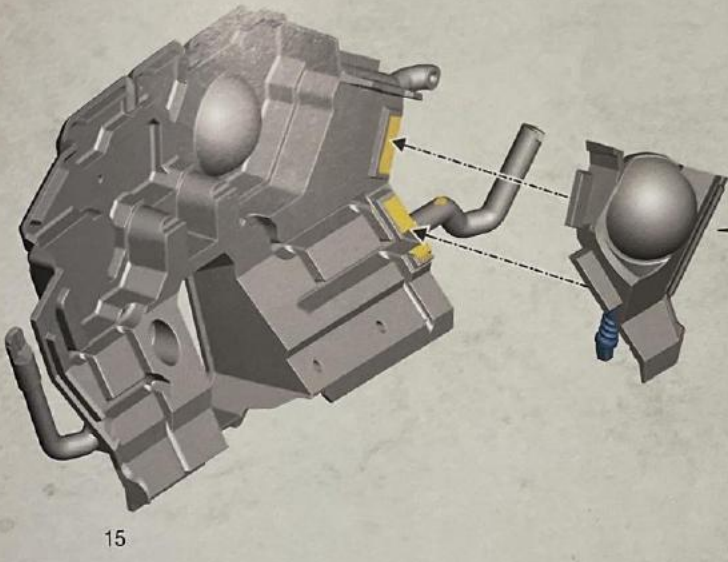

1 c

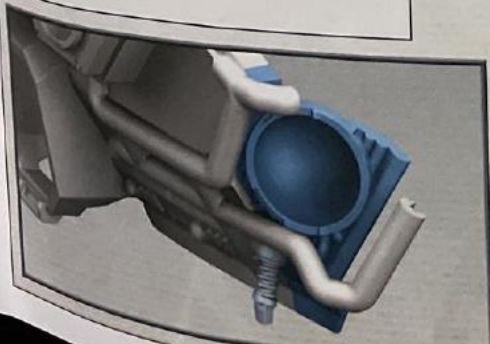
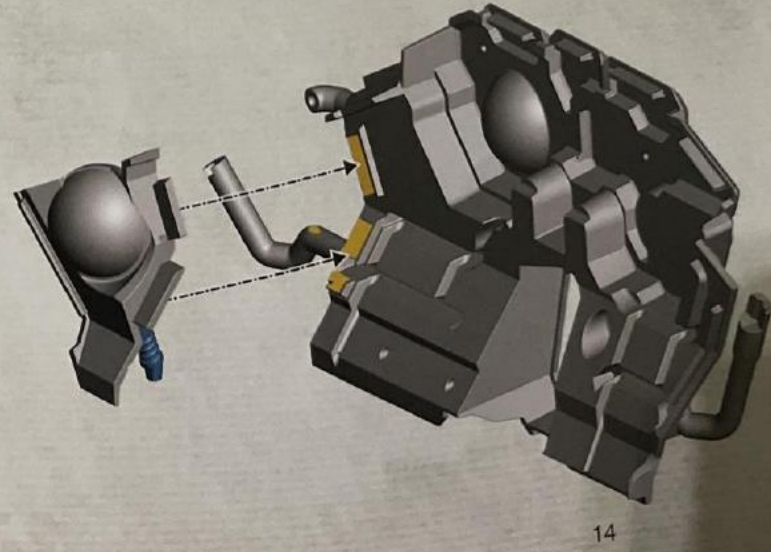
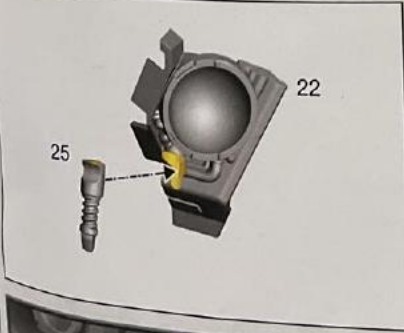

14

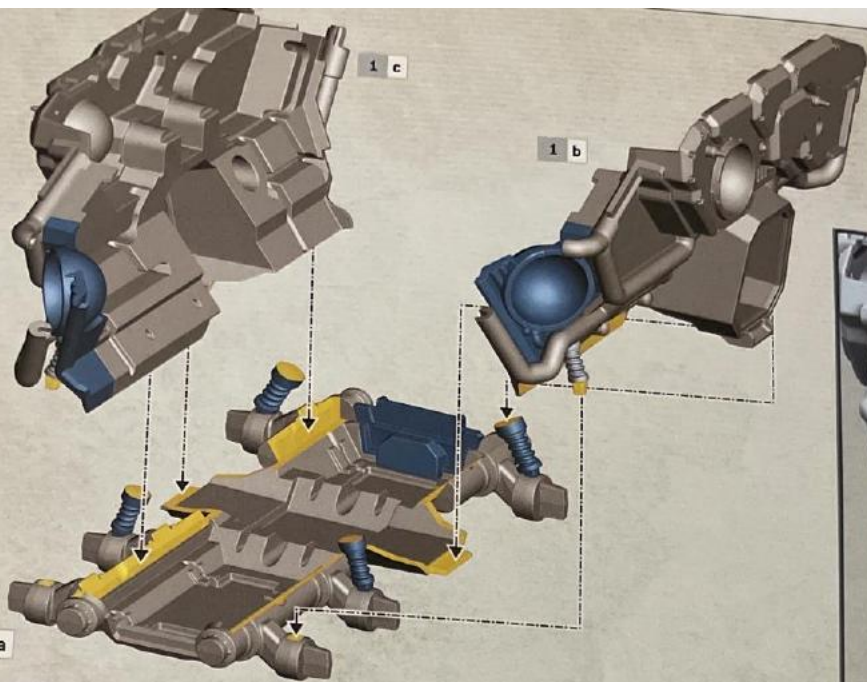

1 e



1 d

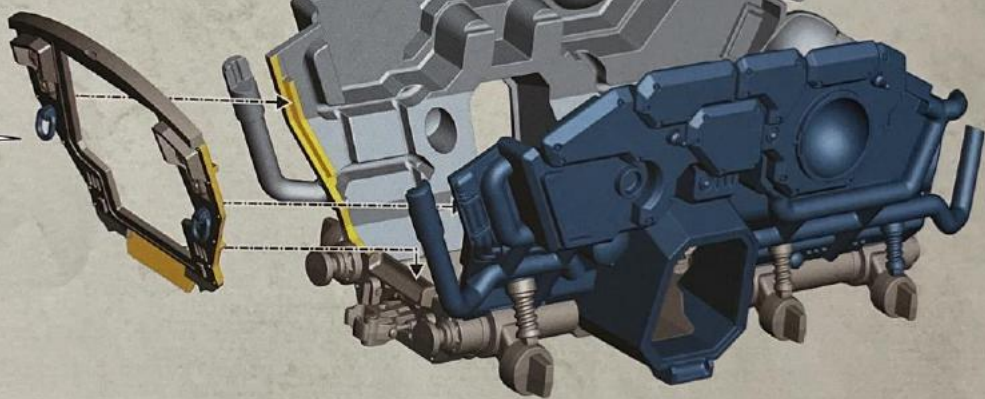

f

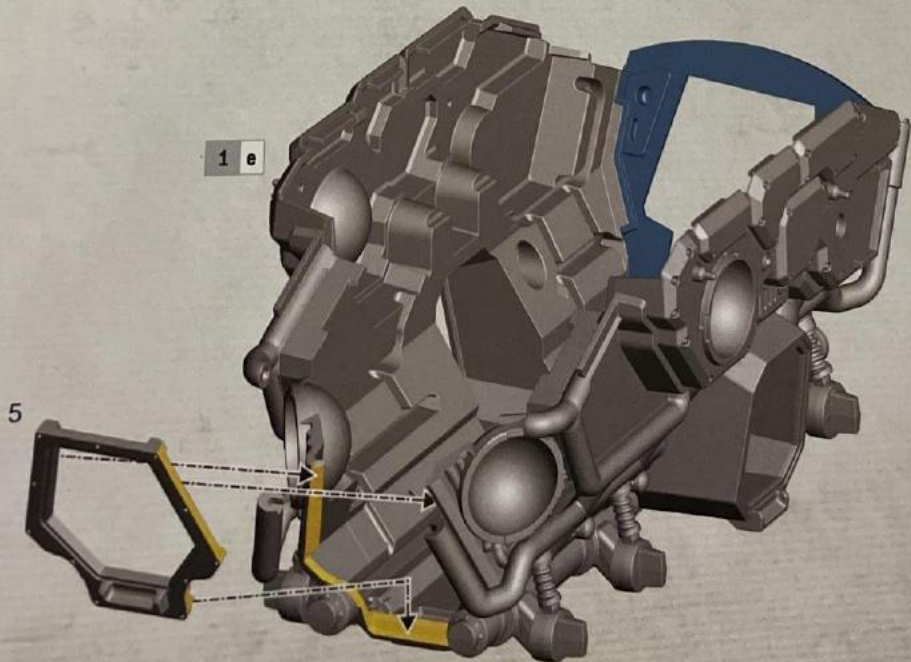

2 a

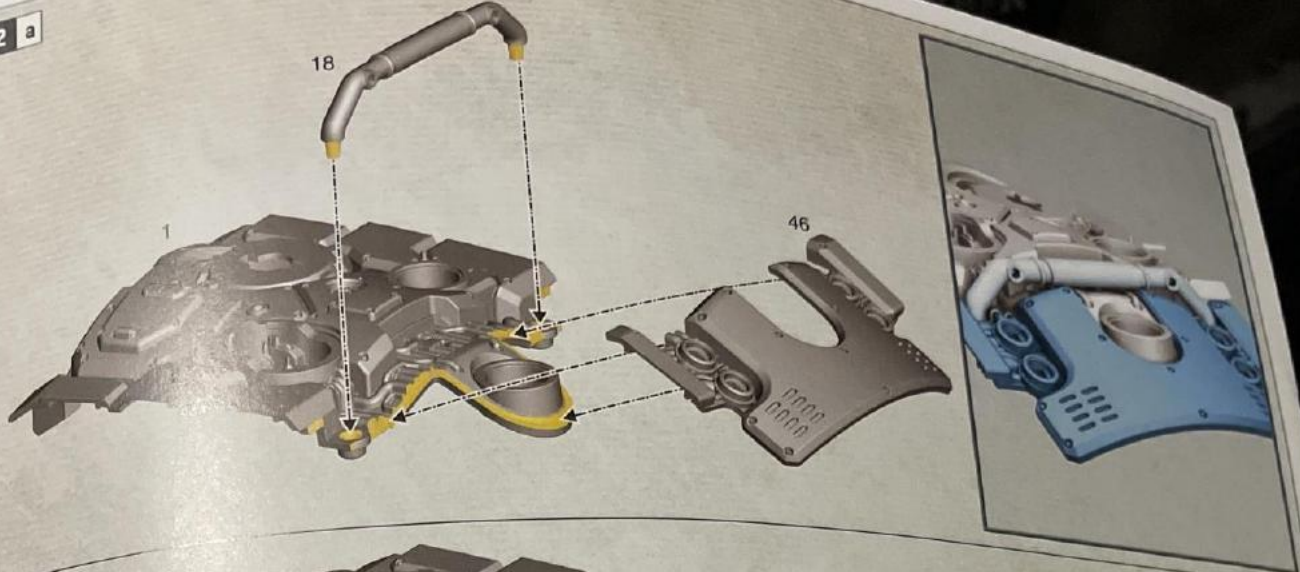

2 b



2 a

2 c

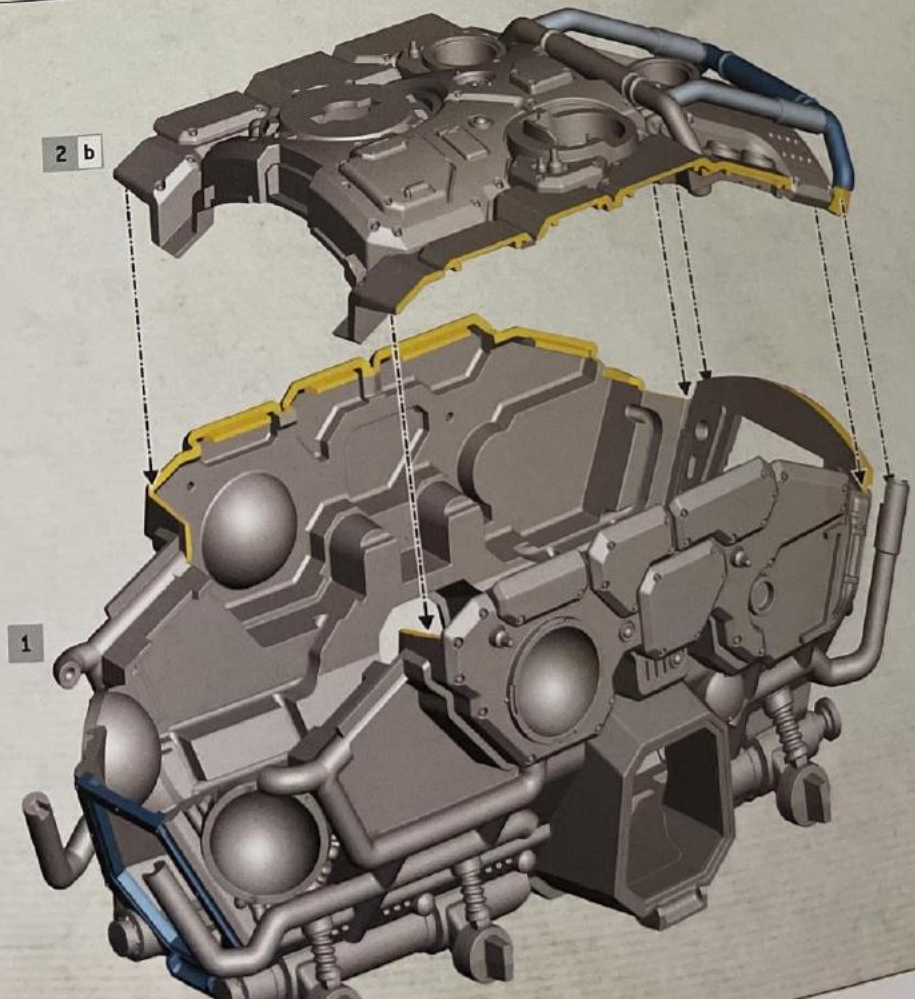

2 b

1

2 d

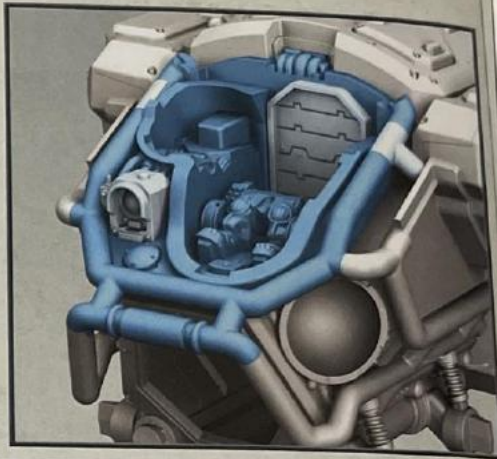
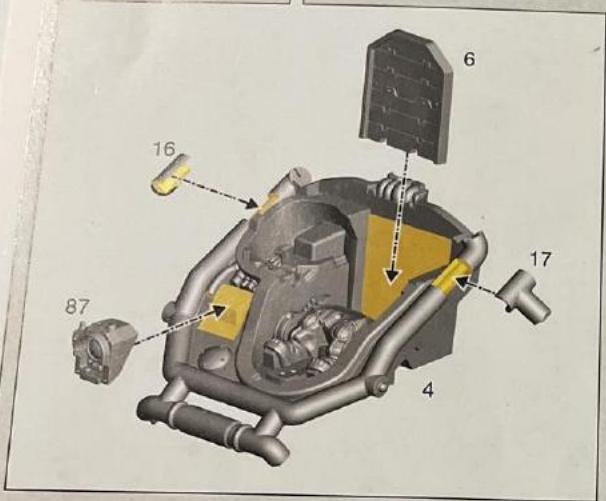
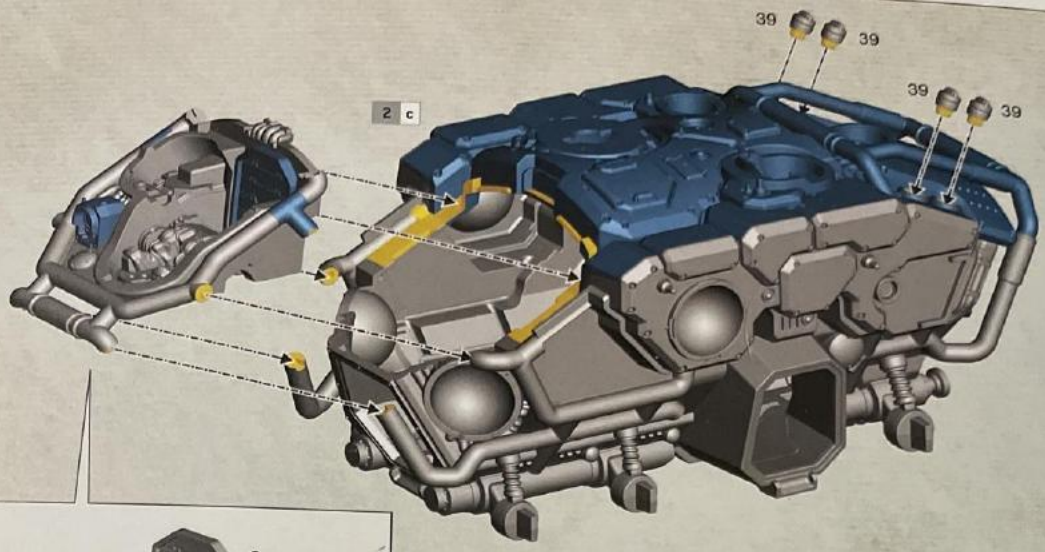

2 e

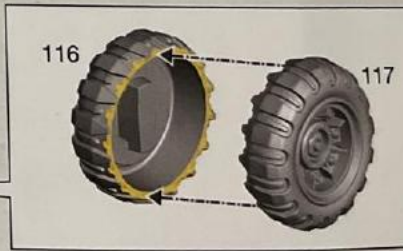
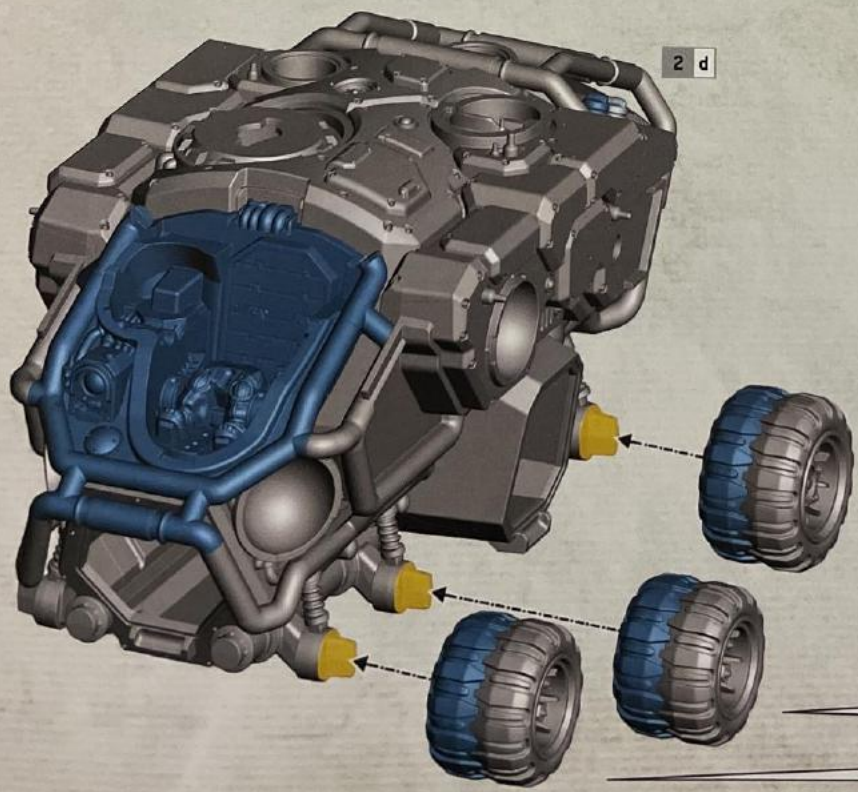

2 f

2 e

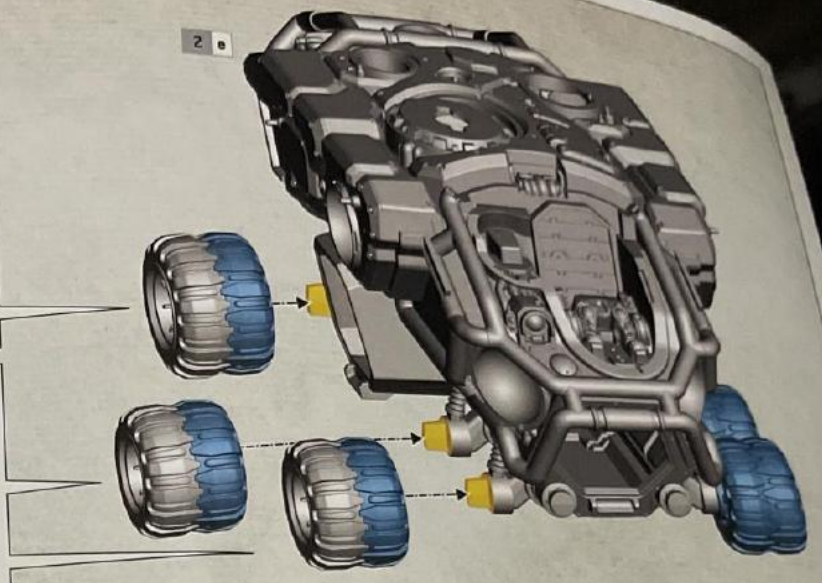
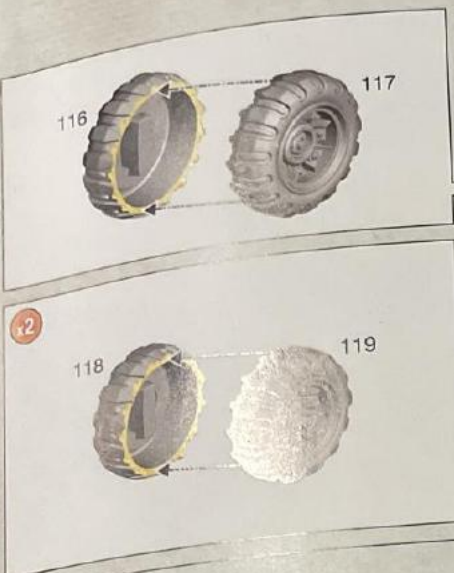

2 B

2 f

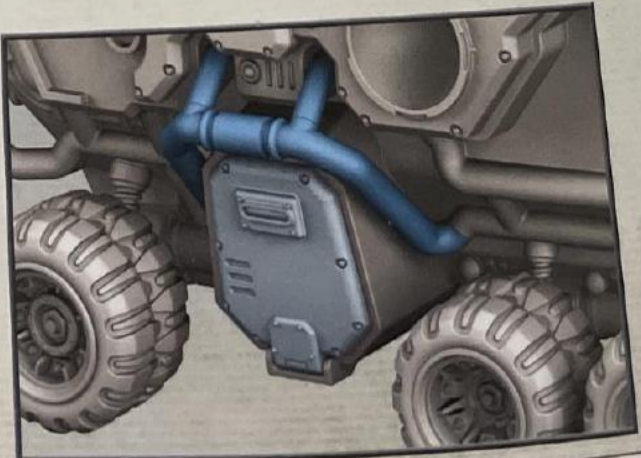
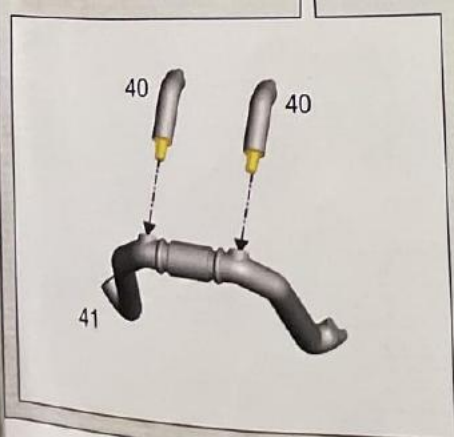
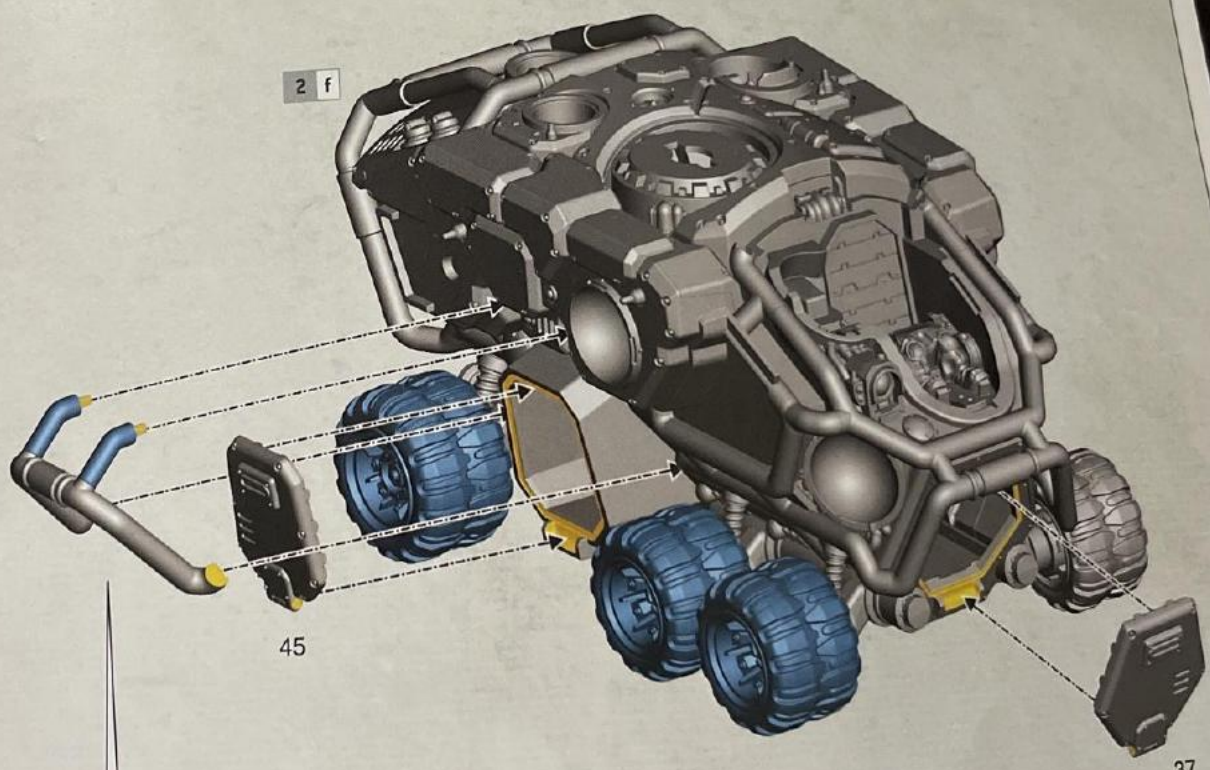



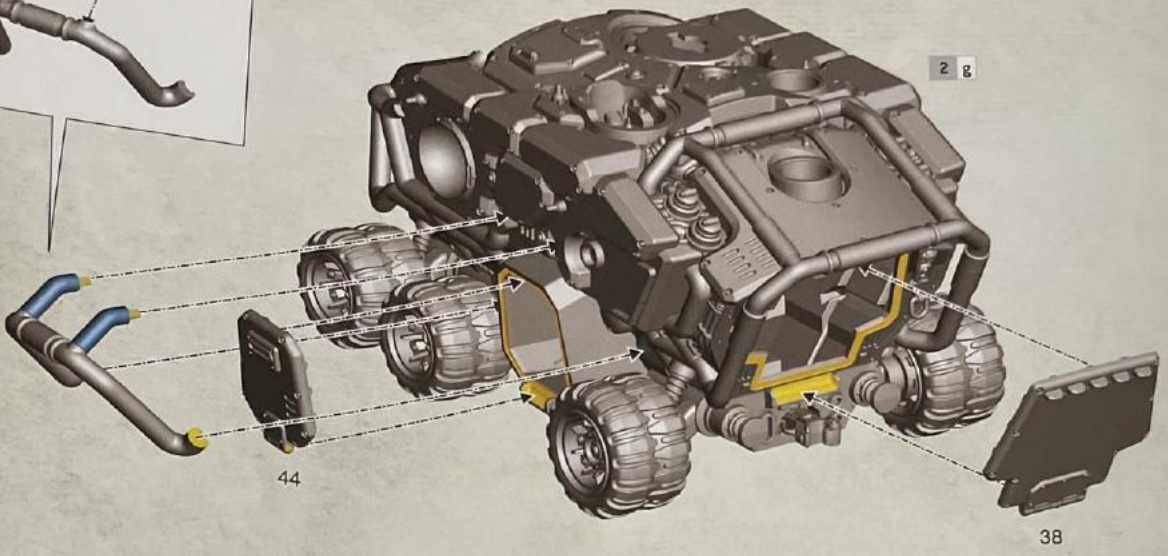
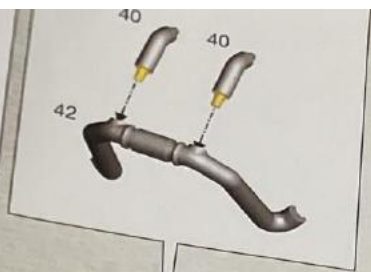

2 i

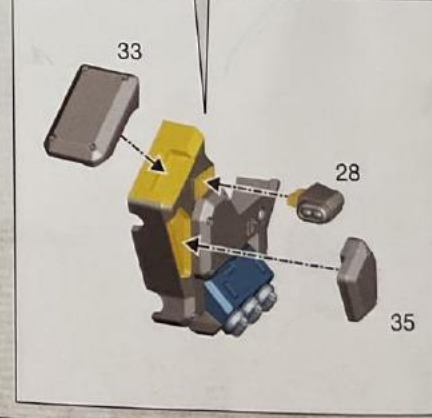
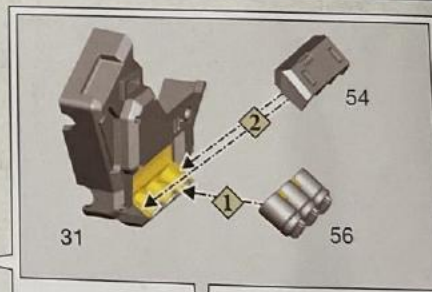
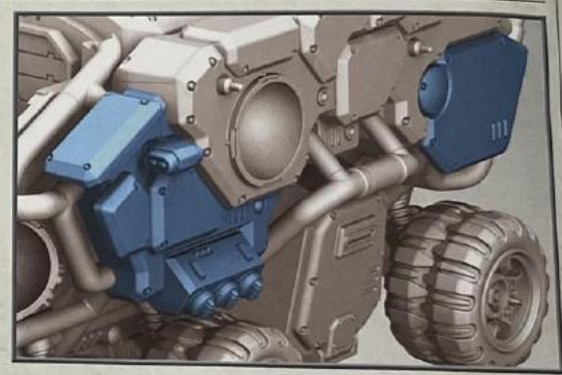
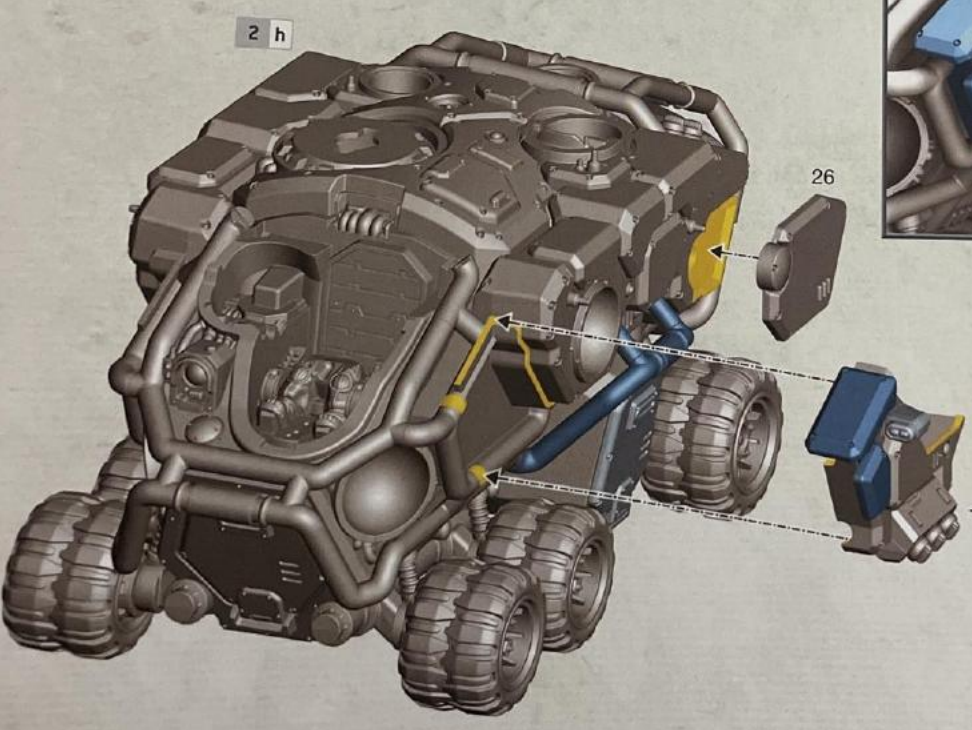

2 1



27

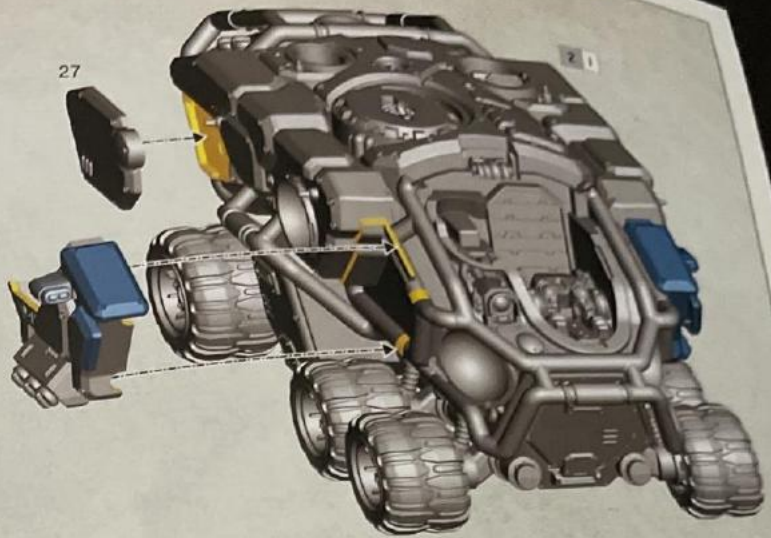

2 1



- 3**
- Choose the variant you want to build
  - Choisissez la variante à assembler
  - Elige qué versión quieres montar
  - Wähle die Variante, die du bauen möchtest
  - Scegli la variante che vuoi assemblare
  - Выберите тот вариант, который хотите собрать
  - 組み立てバリエーションの選択
  - 选择你喜欢的拼装方式

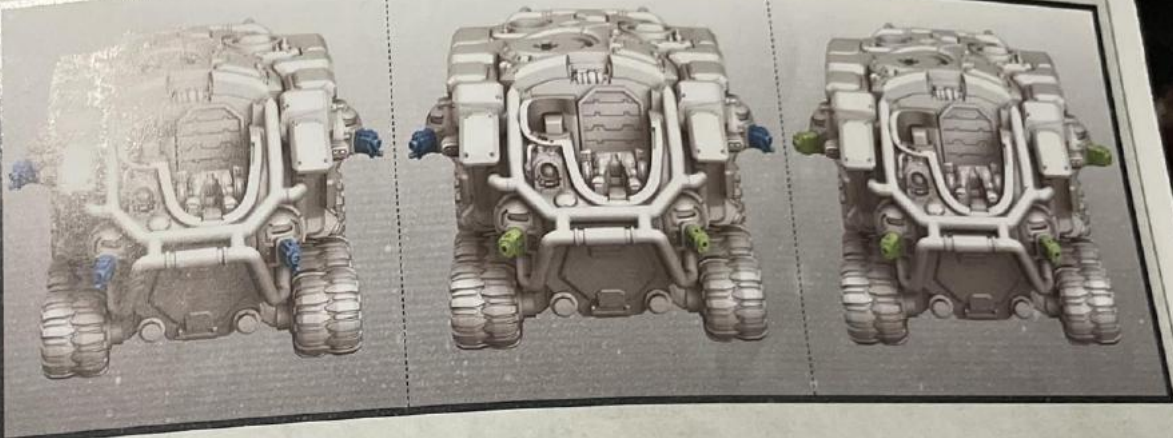

3 a x2

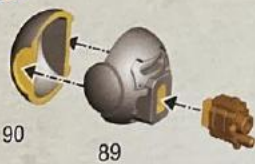

3 b

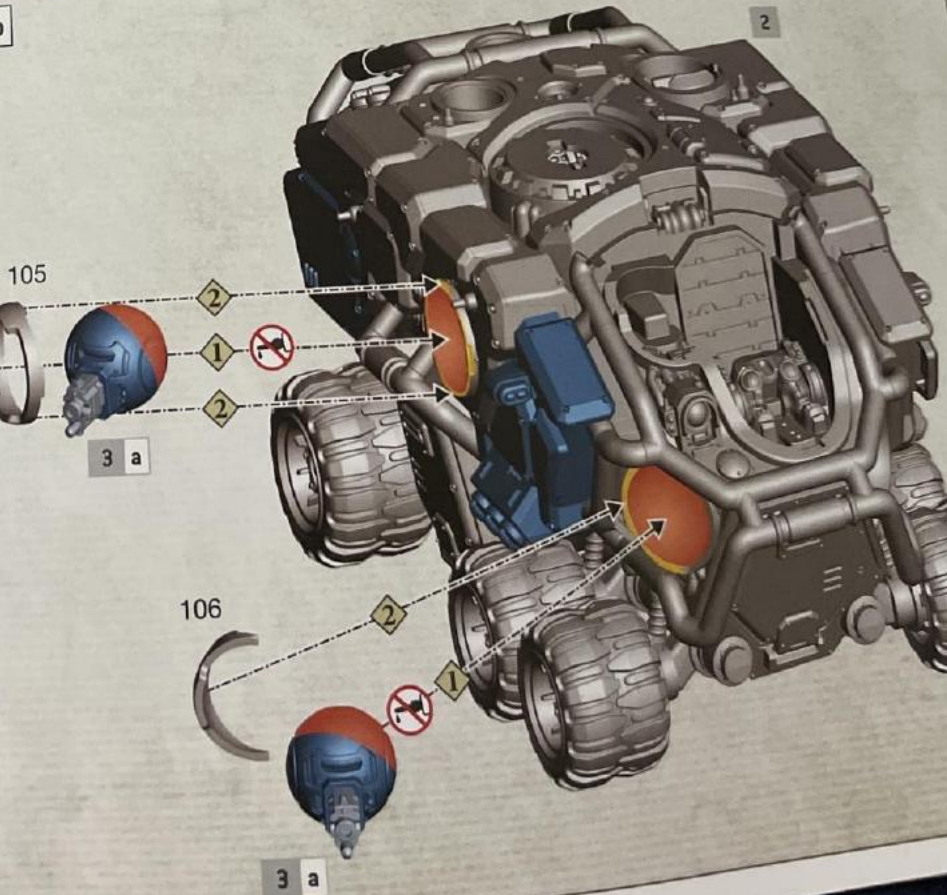

2

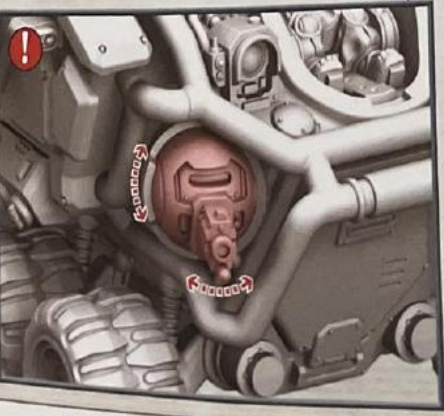

3 d

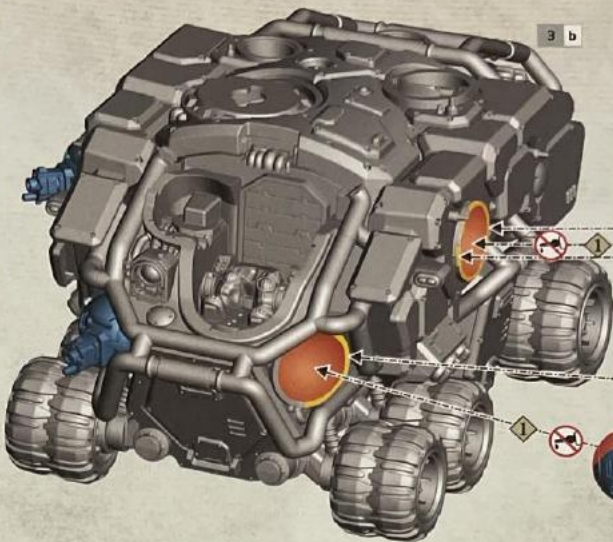
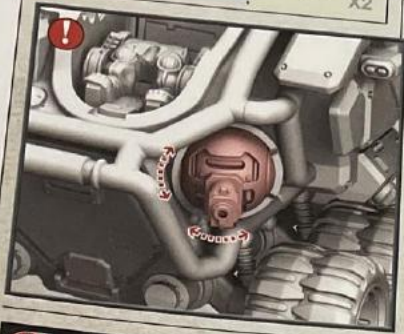

3 b

107

105

3 c

! 4

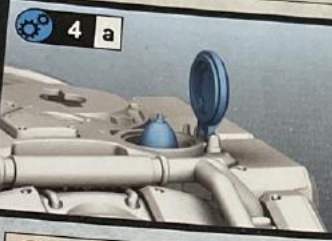

4 a

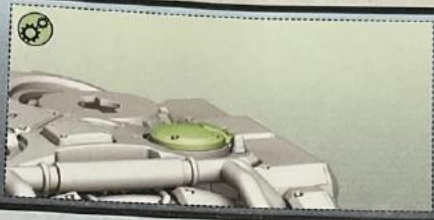

4 b

4 a



4 b



3

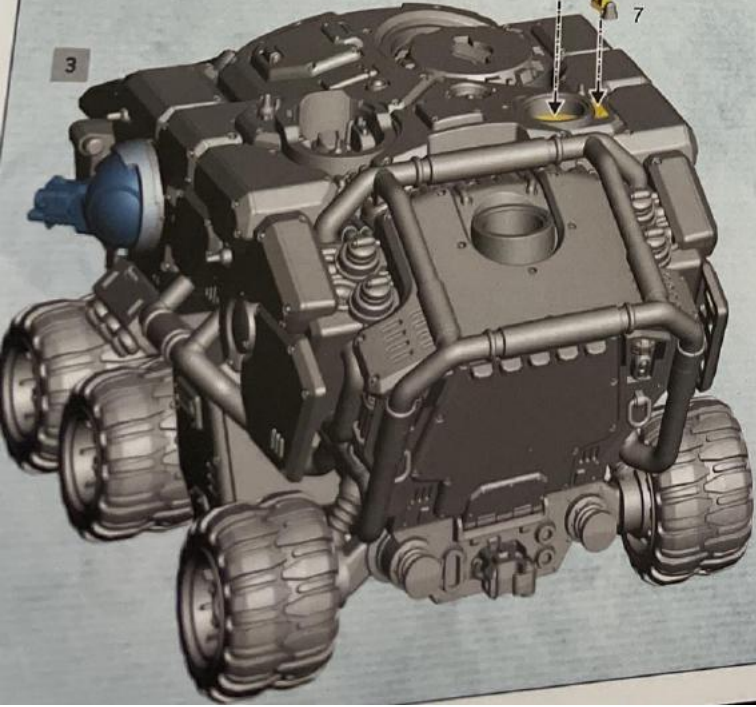

7

3



123

52

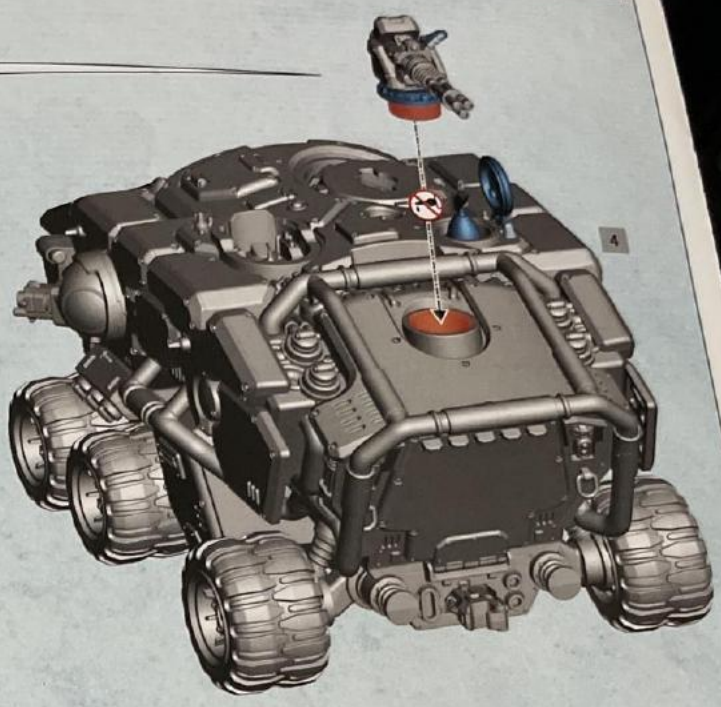
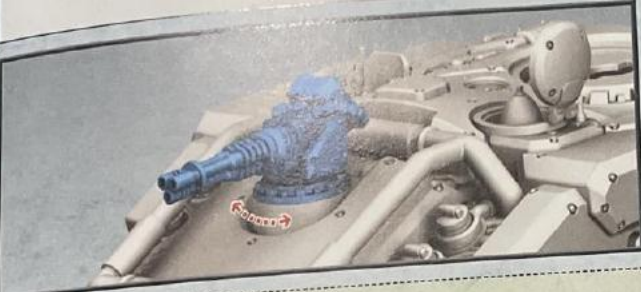
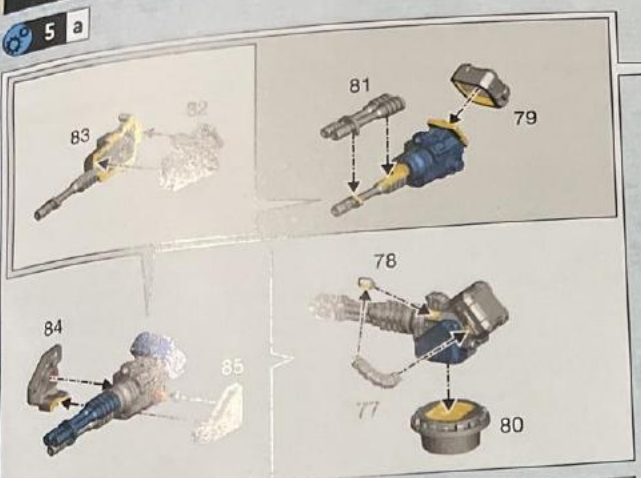
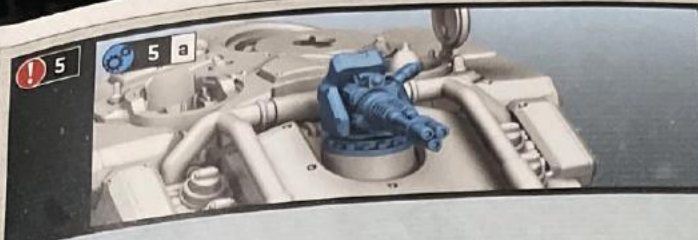

5 b

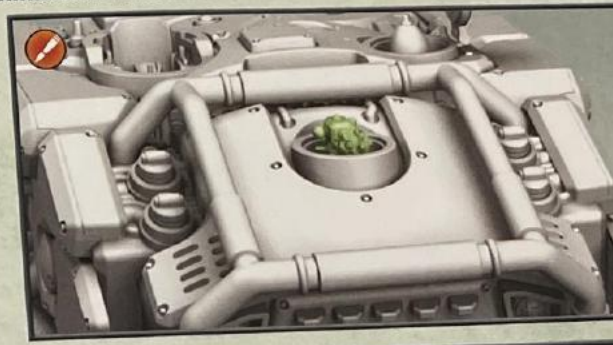
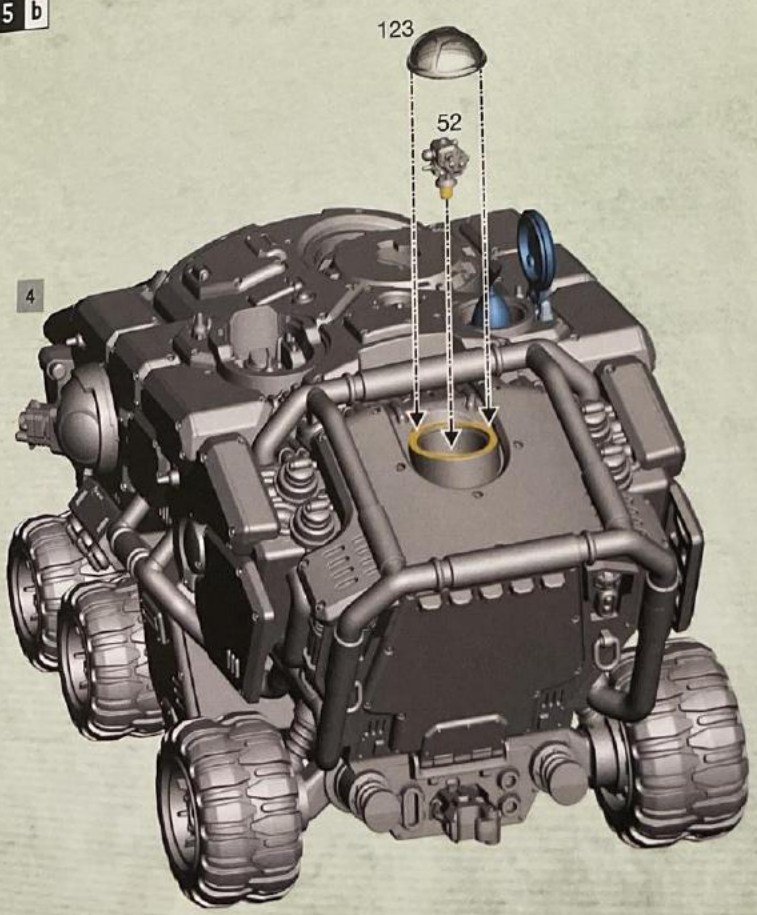

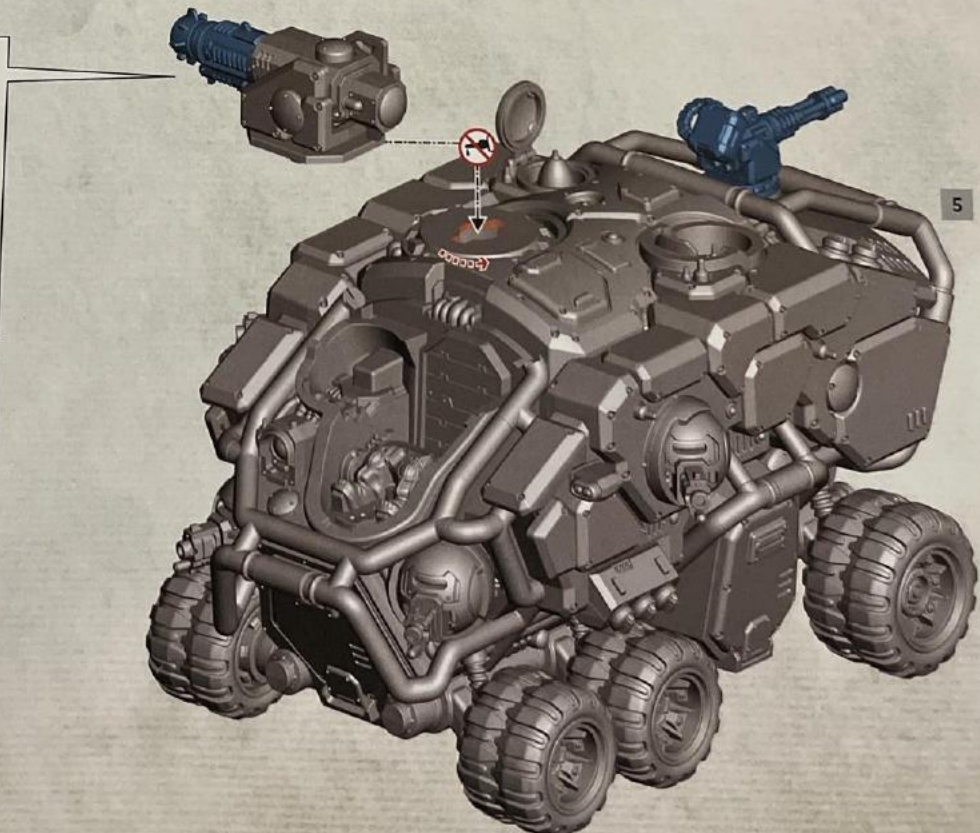
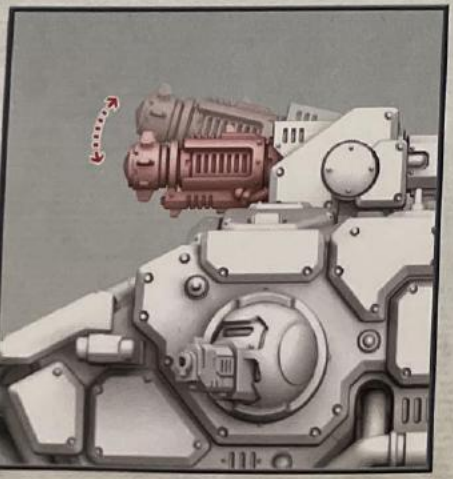
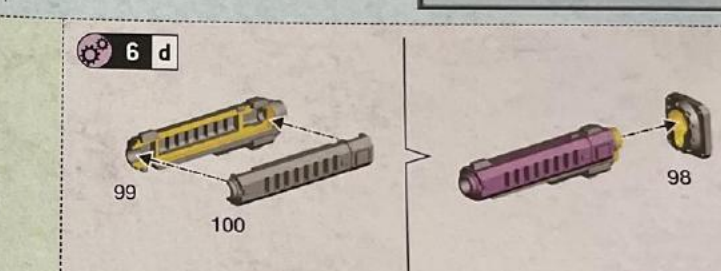
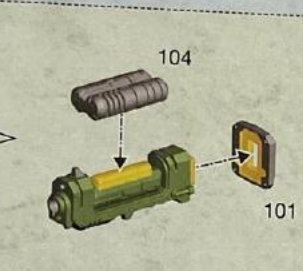
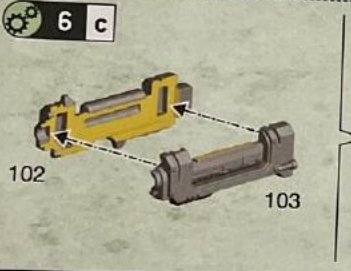
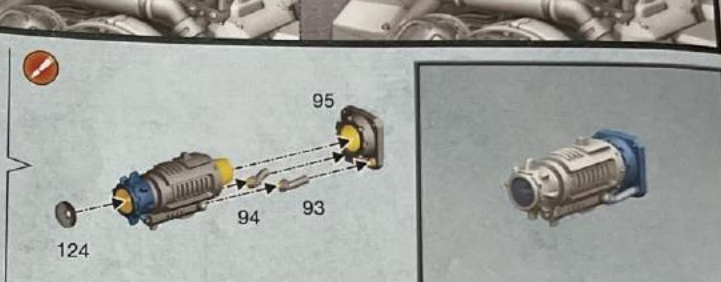
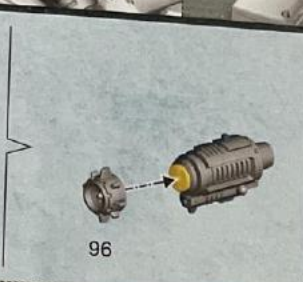
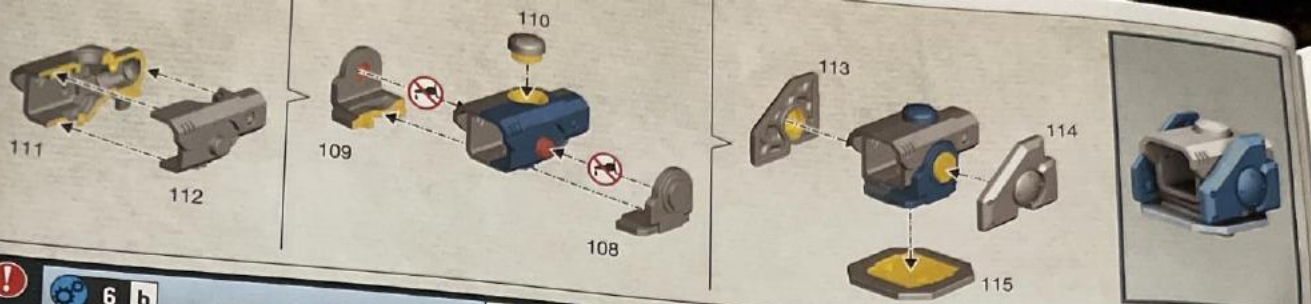

7 a

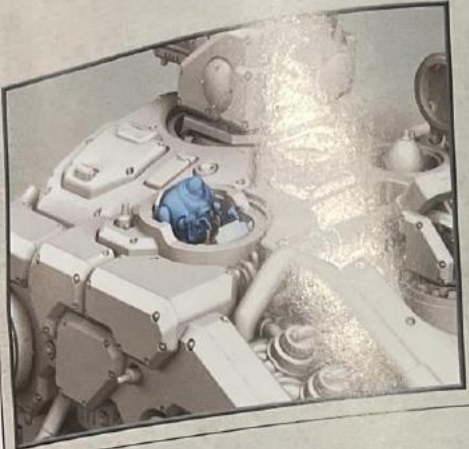
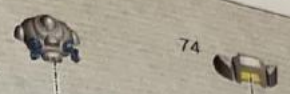

7 b

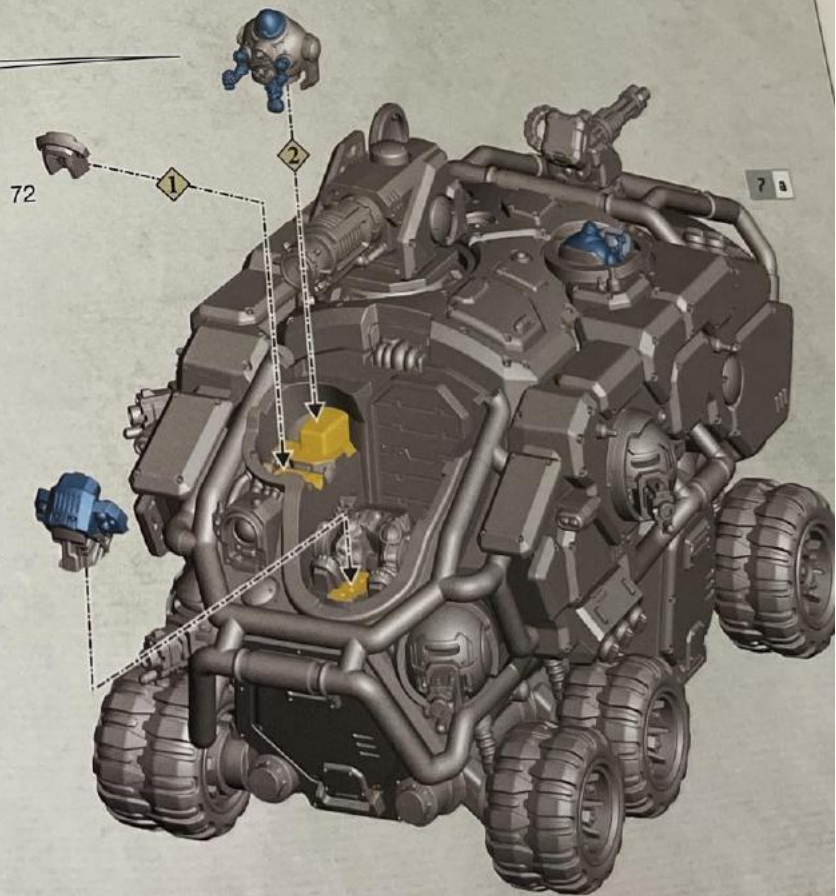

7 a

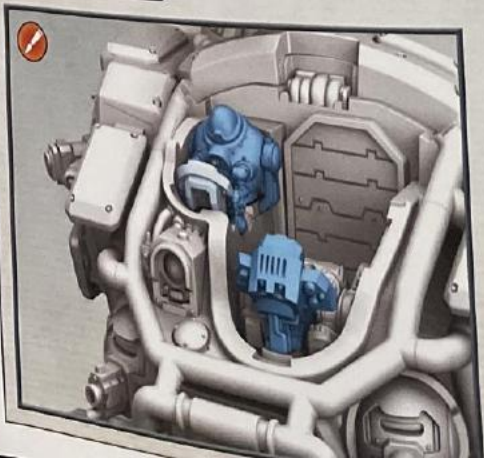

7 c

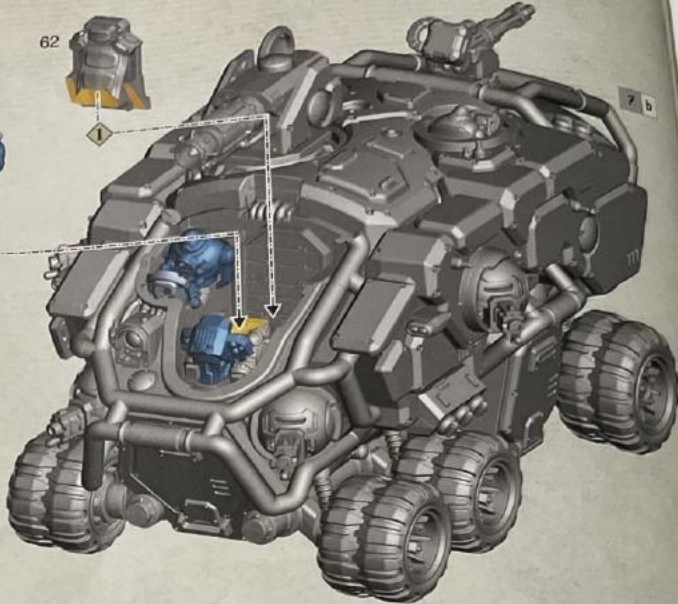
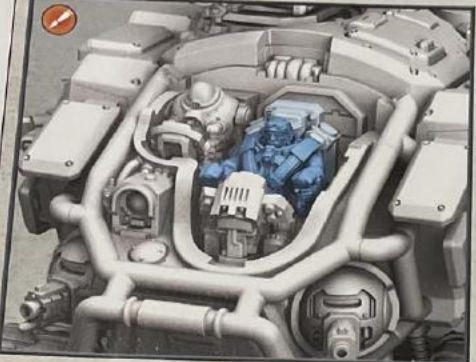

7 e

7 d

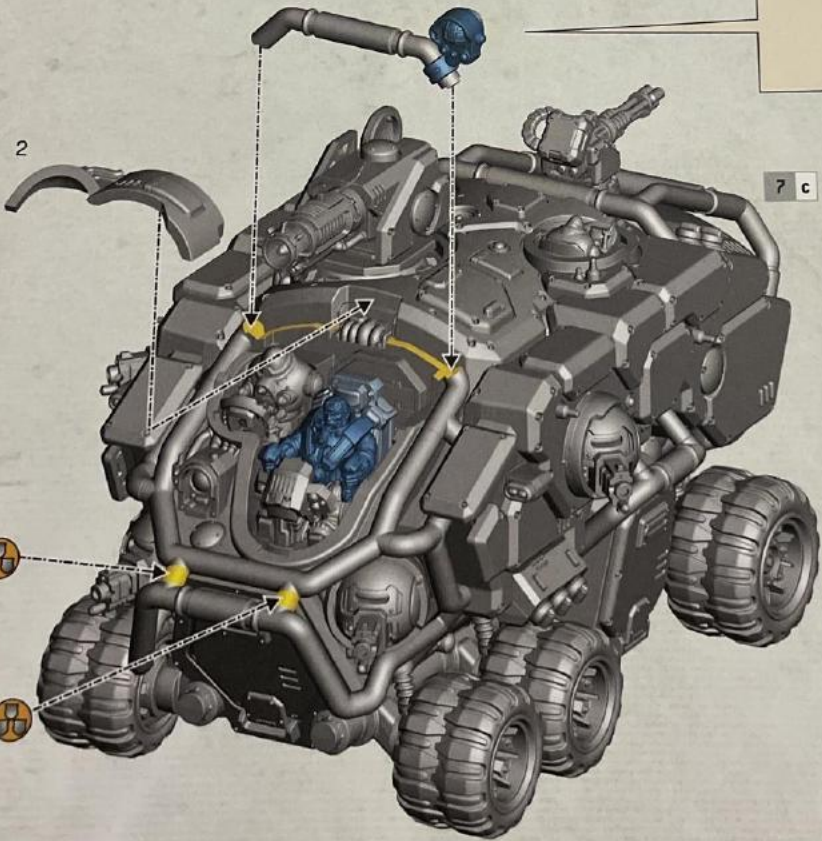
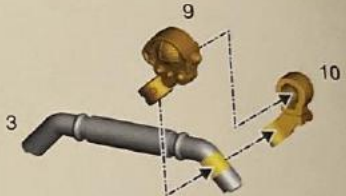

7 c

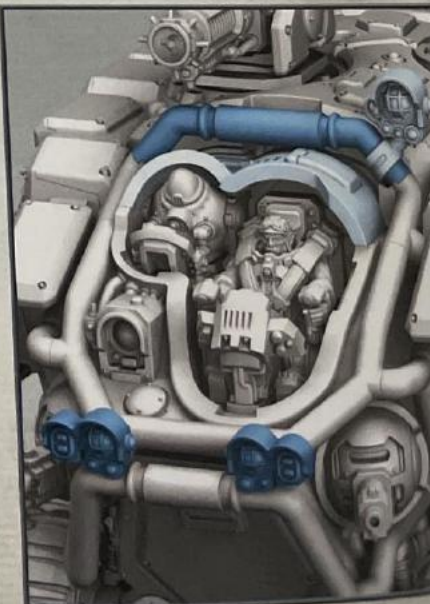

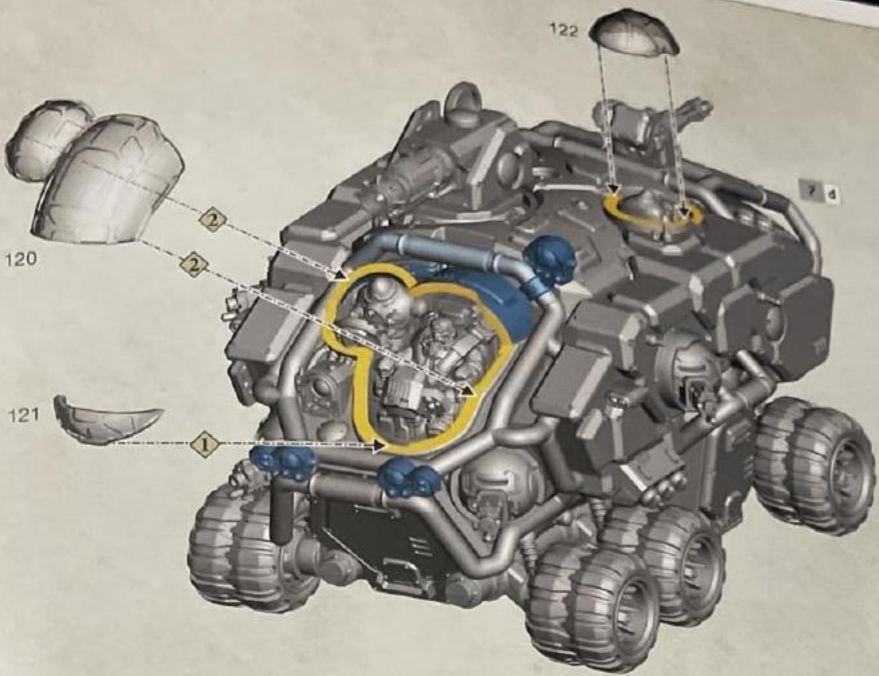

**CITADEL COLOUR**

- ENG** More painting guides can be found on [citadelcolour.com](http://citadelcolour.com)
- FRE** D'autres guides de peinture sont disponibles [citadelcolour.com](http://citadelcolour.com)
- SPA** Encontrarás más guías de pintura en [citadelcolour.com](http://citadelcolour.com)
- GER** Weitere Bemalanleitungen auf [citadelcolour.com](http://citadelcolour.com)
- ITA** Puoi trovare altre guide alla pittura su [citadelcolour.com](http://citadelcolour.com)
- RUS** Дополнительные инструкции по покраске на сайте [citadelcolour.com](http://citadelcolour.com)
- 日** [citadelcolour.com](http://citadelcolour.com) には他にも様々なペイントガイドが掲載されている
- 中文** 更多涂装指南请至 [citadelcolour.com](http://citadelcolour.com)

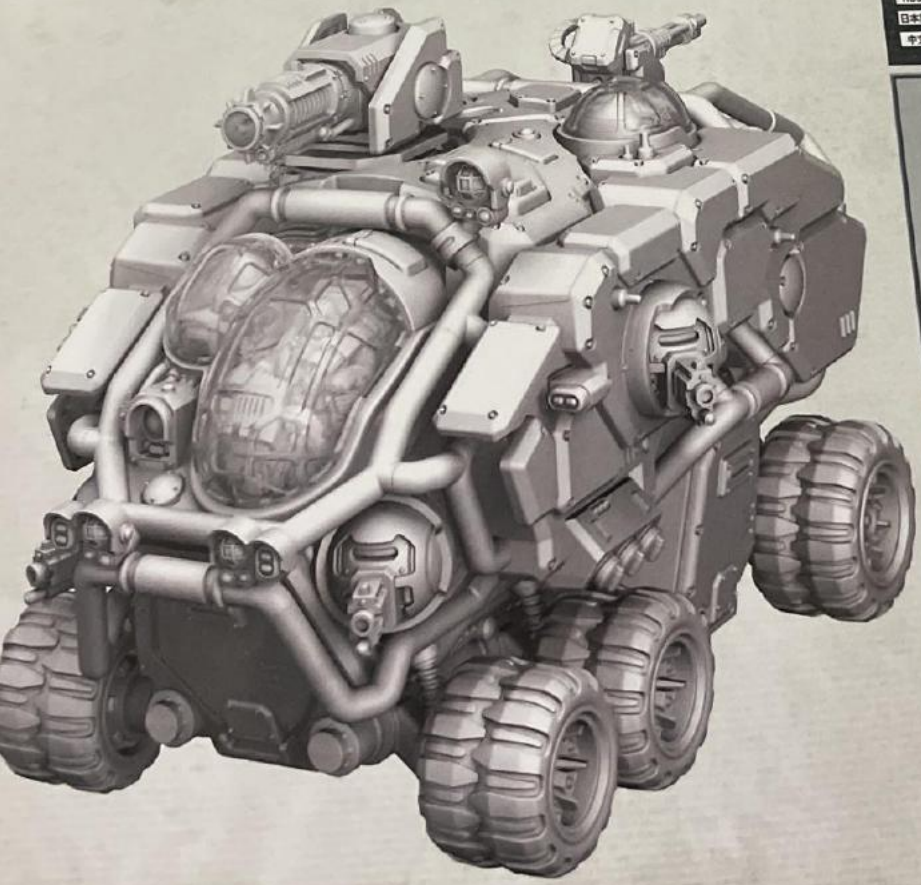





**ENG** Used alongside the core rules found on [warhammer40000.com](http://warhammer40000.com), the essential rules below will get your new unit on the battlefield. For the full rules for this unit, see the Codex relevant to your army.

**FRE** Utilisées avec les règles de base de Warhammer 40000, les règles essentielles ci-dessous vous permettent de jouer votre nouvelle unité sur le champ de bataille. Pour les règles complètes de cette unité, référez-vous au Codex correspondant à votre armée.

**SPA** Usadas junto a las reglas básicas que encontrarás en [warhammer40000.com](http://warhammer40000.com), las siguientes reglas esenciales pondrán tu nueva unidad en el campo de batalla. Para ver las reglas completas de esta unidad, consulta el Codex de tu ejército.

**DEU** Wenn du die Regeln unten zusammen mit den Grundregeln auf [warhammer40000.com](http://warhammer40000.com) verwendest, kannst du deine Einheit direkt auf das Schlachtfeld führen. Die vollständigen Regeln für diese Einheit findest du im entsprechenden Codex für deine Armee.

**ITA** Usate assieme alle regole di base trovate su [warhammer40000.com](http://warhammer40000.com), le regole essenziali qui sotto vi aiuteranno a portare sul campo di battaglia la tua nuova unità. Per le regole complete di questa unità, consulta il Codex corrispondente alla tua armata.

**RUS** Указанные ниже базовые правила и основные правила с [warhammer40000.com](http://warhammer40000.com) помогут привести новый отряд на поле битвы. В Кодексе, относящемся к вашей армии, есть правила для этого отряда.

**JPN** [warhammer40000.com](http://warhammer40000.com) に掲載されているコアルールとともに以下のユニット用基本ルールを使用することで、このユニットを戦場に配備することができます。このユニットの完全ルールについては、このユニットが属するアーミーのコデックスを参照してください。

**CHN** 下方的基本规则需搭配 [warhammer40000.com](http://warhammer40000.com) 上的《核心规则》使用，可助您将新单位带到战场上。有关该单位的完整规则，请参见与您的军队相关的《圣典》。

**HEKATON LAND FORTRESS**

**FORTERRESSE MOBILE HEKATON**

**TERRABASTIÓN HEKATON**

**HEKATON-LANDFESTUNG**

**FORTEZZA SEMOVENTE HEKATON**

**МОБИЛЬНАЯ КРЕПОСТЬ HEKATON**

	10"	8"	6"	8	8	16	6	9	2+
Hekaton Land Fortress (9+)	6+	3+	8	8	8	N/A	D6	9	2+
Hekaton Land Fortress (5-8)	6+	4+	8	8	8	N/A	3	9	2+
Hekaton Land Fortress (1-4)	6+	5+	8	8	8				

	1	2	3	4	5	6	7	8	9
36"	6	6	6	6	6	6	6	6	6
36"	2	2	2	2	2	2	2	2	2
24"	303	8	8	8	8	8	8	8	8
36"	1	14	4	20	2	7	7	7	7
18"	2	7	7	7	7	7	7	7	7
36"	2D6	6	6	6	6	6	6	6	6
24"	6	7	7	7	7	7	7	7	7
36"	1	10	3	6	2	2	2	2	2
30"	2	8	8	8	8	8	8	8	8

