



Free Downloads of Build Instructions,
Assembly Booklets & How To Guides

BuildInstructions.com

GENESTEALER CULTS

CHOOSE THE VARIANT YOU WANT TO BUILD • CHOISISSEZ LA VARIANTE À ASSEMBLER • ELIGE QUÉ VERSIÓN QUIERES MONTAR
WÄHLE DIE VARIANTE, DIE DU BAUEN MÖCHTEST • SCEGLI LA VARIANTE CHE VUOI ASSEMBLARE

GOLIATH ROCKGRINDER



STEPS
ÉTAPES • FASOS
SCHRIITTE • FASI

1 - 5

GOLIATH TRUCK

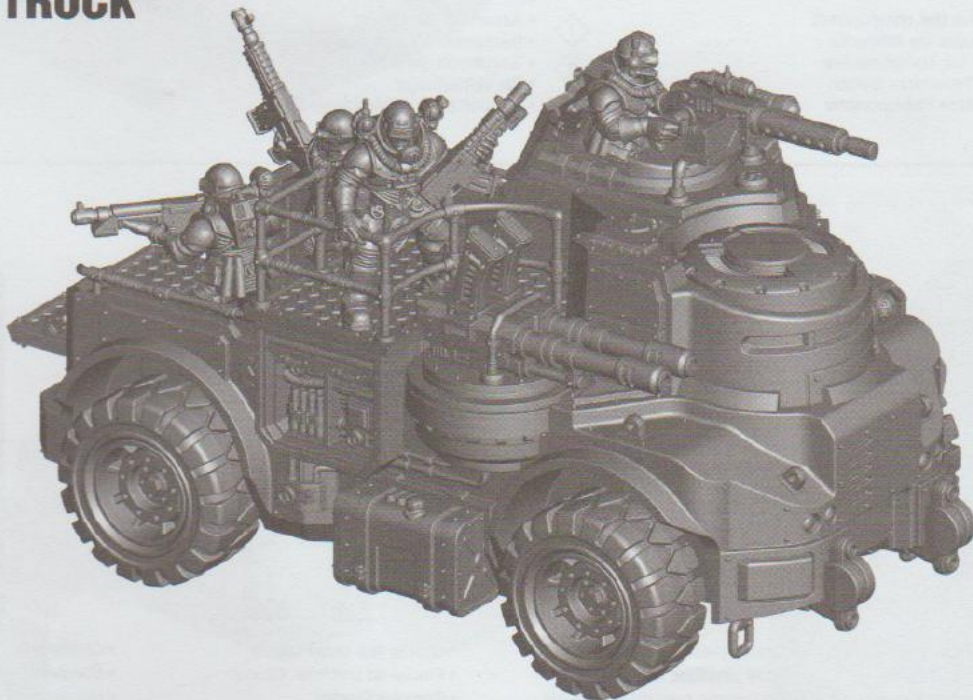

STEPS
ÉTAPES • FASOS
SCHRIITTE • FASI











1 - 2

6 - 10

READ THIS FIRST • À LIRE EN PREMIER • LEER ANTES DE MONTAR • LIES DIES ZUERST • LEGGI PRIMA QUESTO

- Before assembling your model kit please read through the instructions in this booklet carefully. A pair of plastic cutters is required to remove the plastic components in this kit from their frame. We advise using a mouldline scraping tool to clean up the parts. To assemble your model you will need plastic glue. Games Workshop sells Citadel Fine Detail Cutters, Citadel Mouldline Remover and Citadel Plastic Glue, but does not recommend these products for use by children under the age of 16 without adult supervision.
- Avant de vous lancer dans l'assemblage de ce kit, veuillez lire attentivement les instructions de ce livret. Une pince coupante est requise pour détacher chaque élément de sa grappe. Nous vous recommandons l'utilisation d'un grattoir pour ébarber les éléments. Pour l'assemblage, vous aurez également besoin de colle plastique. Games Workshop commercialise les Pincés de Précision Citadel, l'Ébarboir Citadel et la Colle Plastique Citadel, mais n'en recommande pas l'utilisation pour des enfants de moins de 16 ans sans la supervision d'un adulte.
- Antes de montar el contenido de este kit, lee estas instrucciones cuidadosamente. Te harán falta unas tenazas para plástico a fin de separar las piezas de la matriz. También aconsejamos una herramienta para rebabas a fin de limpiar cada pieza. Para montar la miniatura necesitarás pegamento para plástico. Games Workshop vende Tenazas Citadel, Herramientas para rebabas Citadel y Pegamento para plástico Citadel, pero no recomienda estos productos a menores de 16 años sin la supervisión de un adulto.
- Bitte lies diese Anleitung sorgfältig, bevor du mit dem Zusammenbau deines Modells beginnst. Du benötigst einen Kunststoffseitenschneider, um die Kunststoffbauteile aus dem Gussrahmen herauszutrennen, und Kunststoffkleber, um die Miniatur zusammenzubauen. Außerdem empfehlen wir, die Bauteile vorher mit einem Gussgratentferner zu säubern. Games Workshop bietet Präzisions-Kunststoffseitenschneider von Citadel sowie Citadel-Kunststoffkleber an, empfiehlt aber, dass Kinder unter 16 Jahren diese nur unter Aufsicht eines Erwachsenen benutzen.
- Prima di assemblare il tuo modello, leggi le istruzioni di questo libretto con attenzione. Sono necessarie un paio di tronchesine per plastica per staccare i componenti dai loro sprue. Consigliamo di usare un attrezzo apposito per pulire i componenti. Per assemblare il modello avrai bisogno di colla per plastica. Games Workshop vende Tronchesine di precisione Citadel, Attrezzo per ripulire Citadel e Colla per plastica Citadel, ma non consiglia questi prodotti ad un pubblico minore di 16 anni senza la supervisione di un adulto.

Explanation of symbols • Explication des symboles • Explicación de símbolos • Erläuterung der Symbole • Legenda dei simboli

- | | | |
|---|--|--|
|  <ul style="list-style-type: none"> • Special instruction - Please read • Instructions spéciales - Lire attentivement • Instrucción especial: Por favor, léela • Besondere Anweisung - Bitte lesen • Istruzioni speciali - Leggi attentamente |  <ul style="list-style-type: none"> • Choice of parts • Choix d'éléments • Modelos de componentes • Auswahl an Teilen • Scelta di componenti |  <ul style="list-style-type: none"> • Repeat process • Répéter l'étape • Repetir pasos • Vorgang wiederholen • Ripeti il processo |
|  <ul style="list-style-type: none"> • Dry fit stage before gluing • Tester avant de coller • Comprobar el encaje antes de pegar • Positionierung erst ohne Klebstoff ausprobieren • Prova a secco prima di incollare |  <ul style="list-style-type: none"> • Variant assembly • Variante d'assemblage • Variante de montaje • Bauvariante • Assemblaggio alternativo |  <ul style="list-style-type: none"> • Rotate part • Faire pivoter • Girar la pieza • Teil drehen • Ruota il componente |
|  <ul style="list-style-type: none"> • Paint before assembly • Peindre avant assemblage • Pintar antes del montaje • Erst bemalen, dann zusammenbauen • Dipingi prima dell'assemblaggio |  <ul style="list-style-type: none"> • Detail view • Vue détaillée • Vista detallada • Alternative Ansicht • Visuale del dettaglio |  <ul style="list-style-type: none"> • Stage complete • Étape terminée • Paso completado • Schritt abgeschlossen • Fase completa |
|  <ul style="list-style-type: none"> • Do not glue the components • Ne pas coller les éléments • No pegar los componentes • Bitte die Teile nicht kleben • Non incollare i componenti |  <ul style="list-style-type: none"> • Assembly sequence • Séquence d'Assemblage • Secuencia de montaje • Baureihenfolge • Sequenza di assemblaggio | |

16+



- Citadel plastic glue thick
- Colle plastique épaisse Citadel
- Pegamento para plástico espeso
- Citadel-Kunststoffkleber (Dickflüssig)
- Colla per plastica densa Citadel



- Citadel plastic glue thin
- Colle plastique liquide Citadel
- Pegamento para plástico fluido
- Citadel-Kunststoffkleber (Dünnflüssig)
- Colla per plastica fluida Citadel



- Citadel fine detail cutters
- Pincés de précision Citadel
- Tenazas Citadel
- Präzisions-Kunststoffseitenschneider
- Tronchesine di precisione Citadel



- Citadel mouldline remover
- Ébarboir Citadel
- Herramienta para rebabas Citadel
- Gussgratentferner
- Attrezzo per ripulire Citadel



Follow step 1-2 for all variants • Suivre les étapes 1-2 pour toutes les variantes • Sigue los pasos 1-2 para todas las variantes
Folge den Schritten 1-2 für alle Varianten • Segui le fasi da 1 a 2 per tutte le varianti

1 a

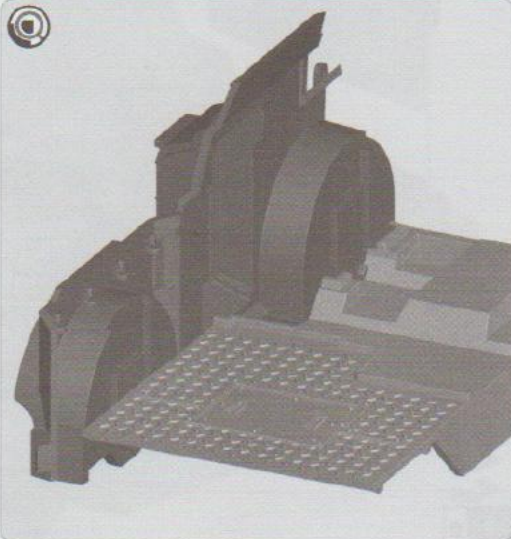
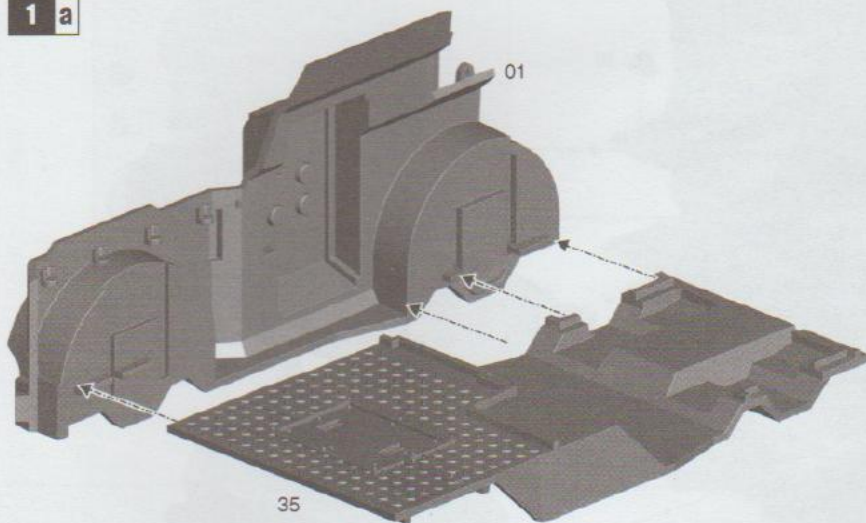

1 b

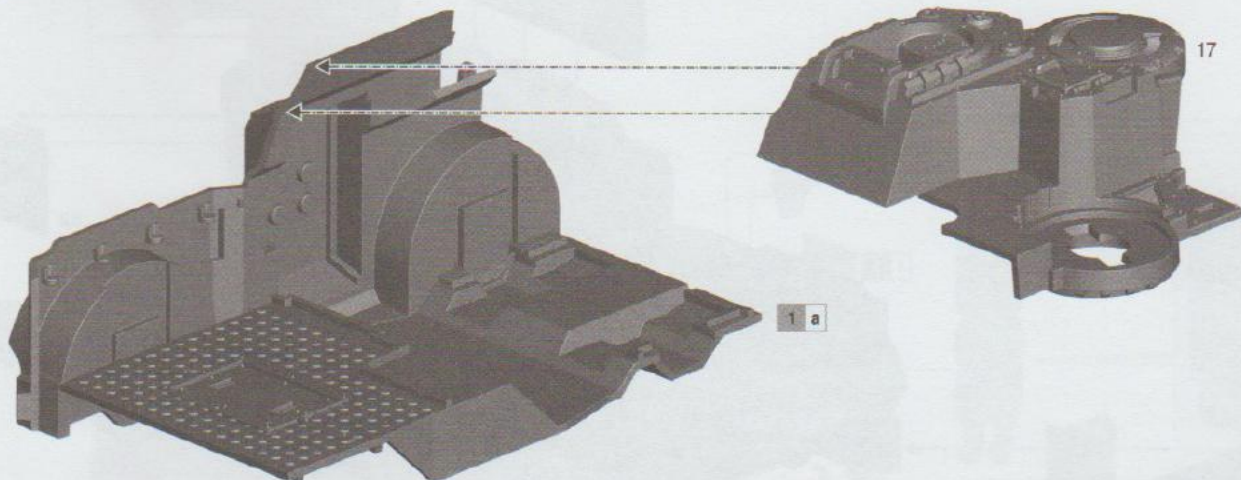

1 c

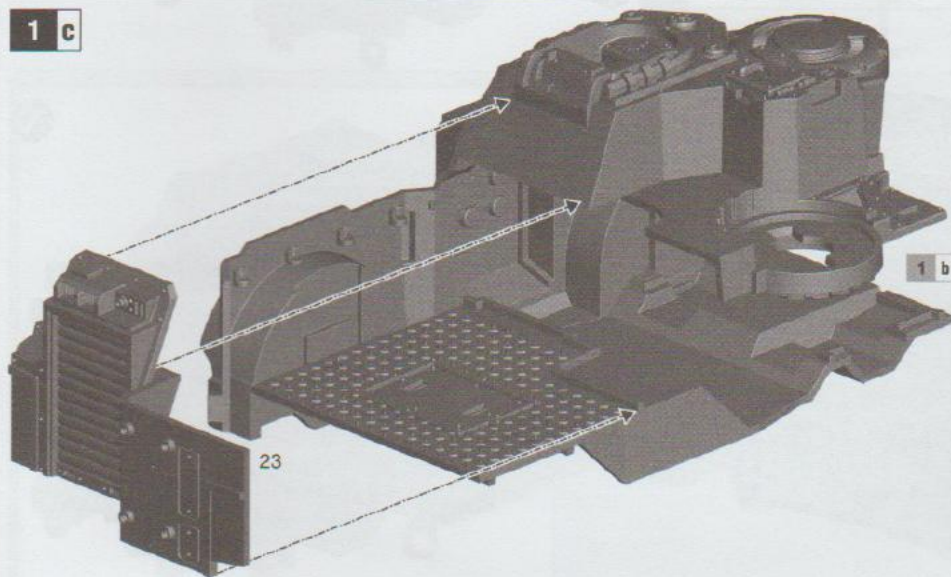

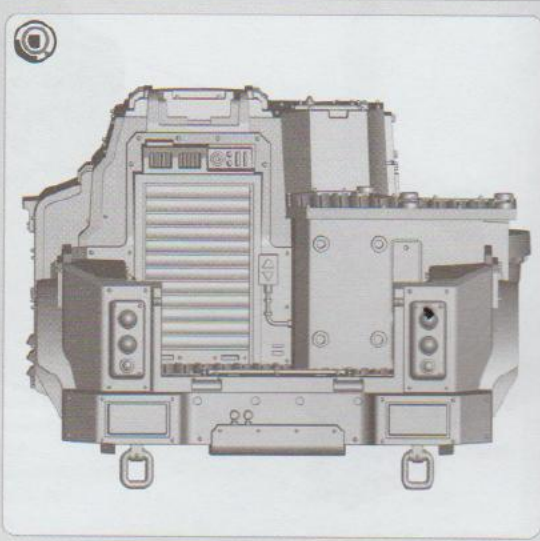
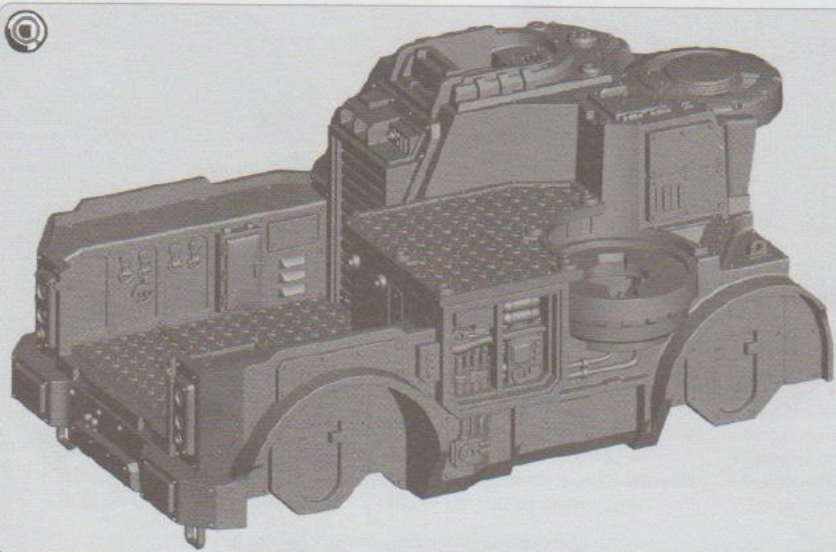
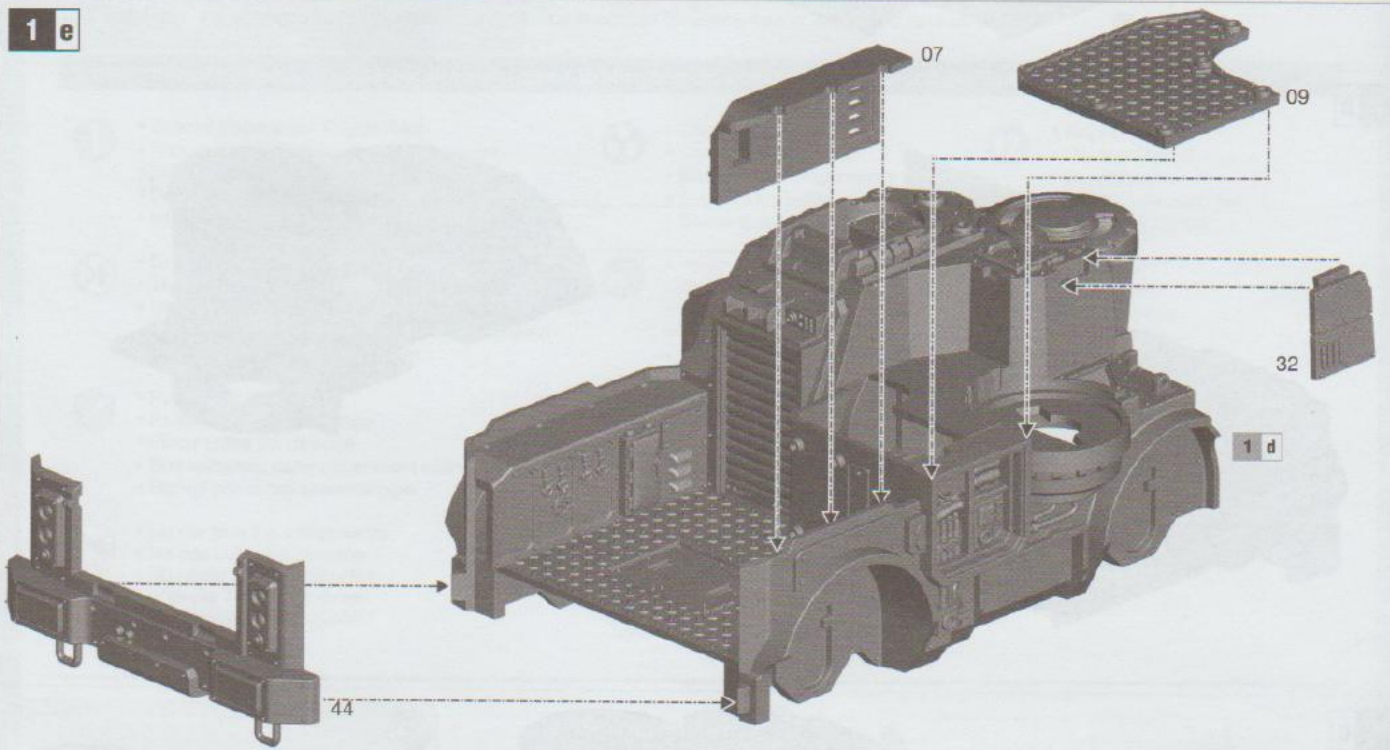
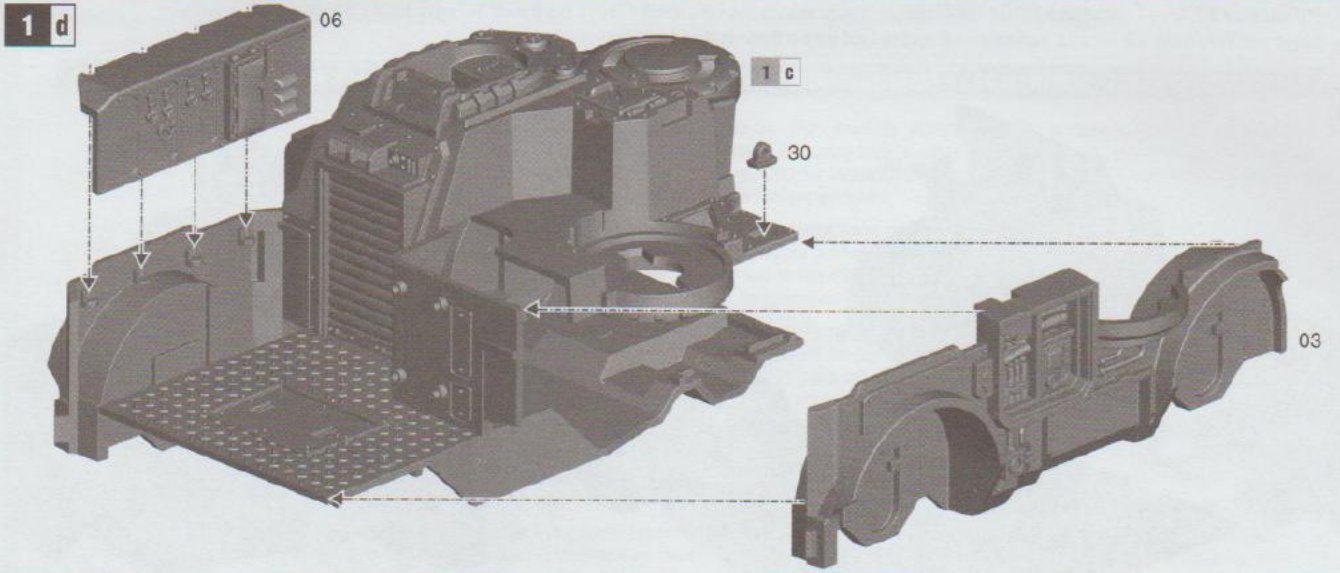

1 f

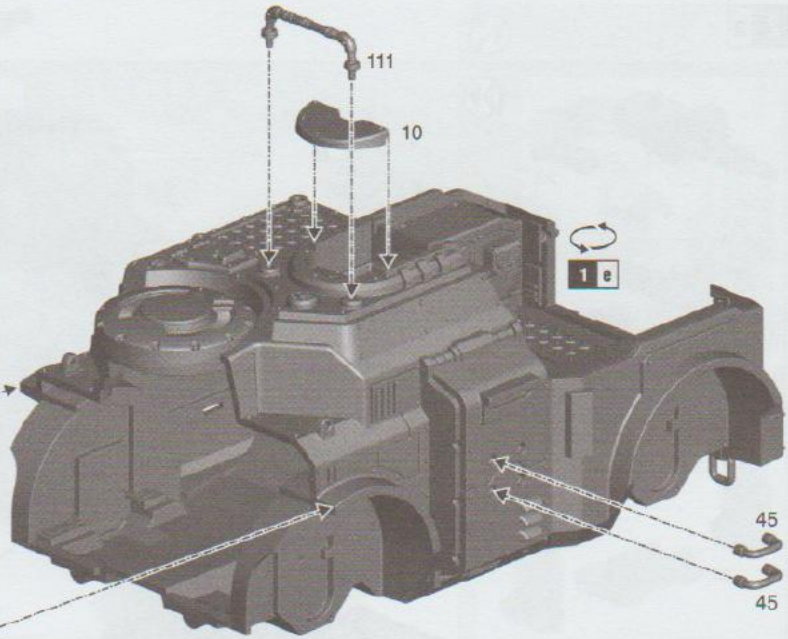
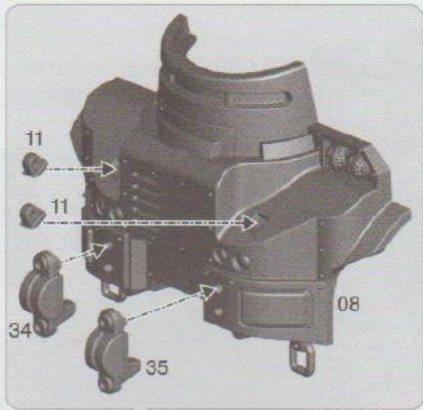

1 g

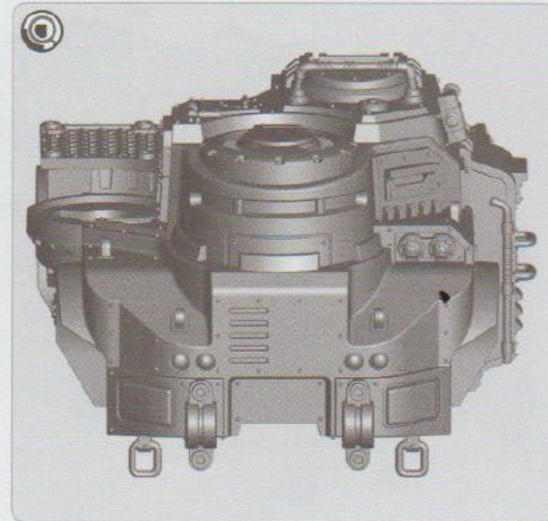
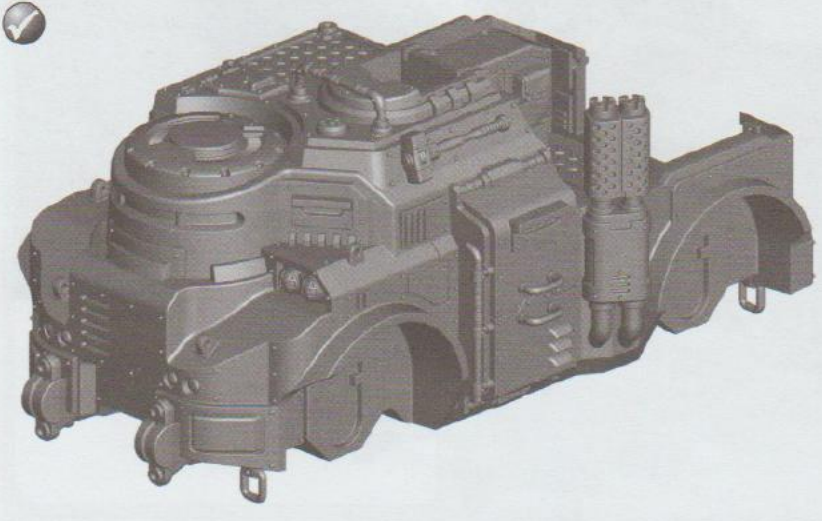
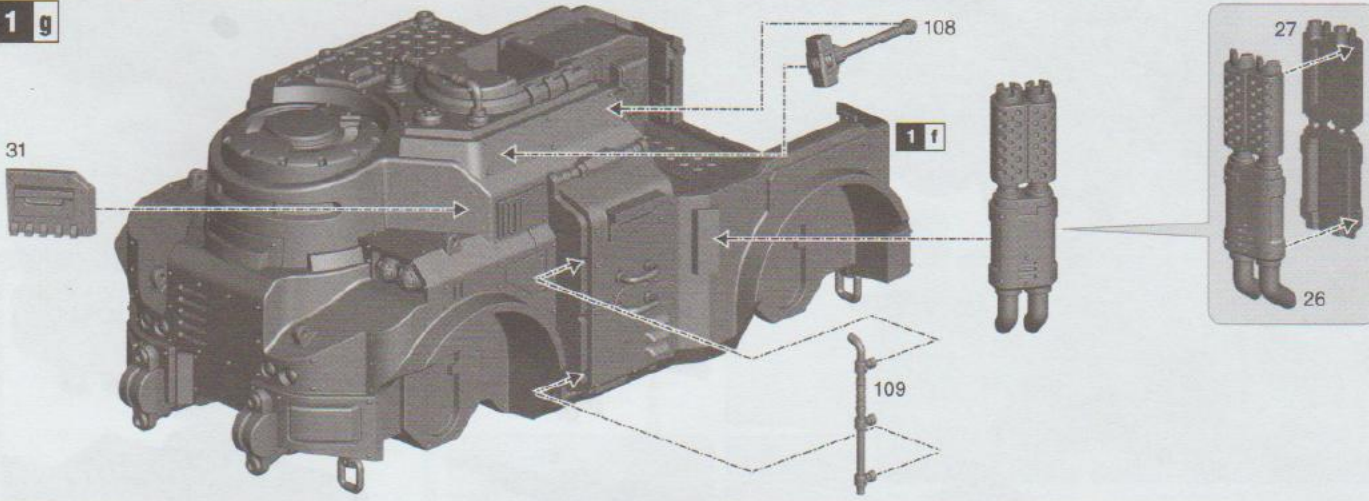

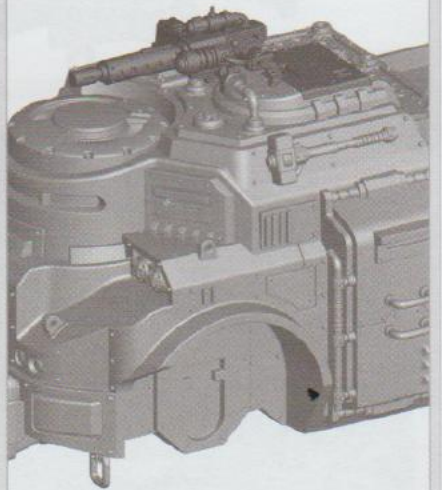
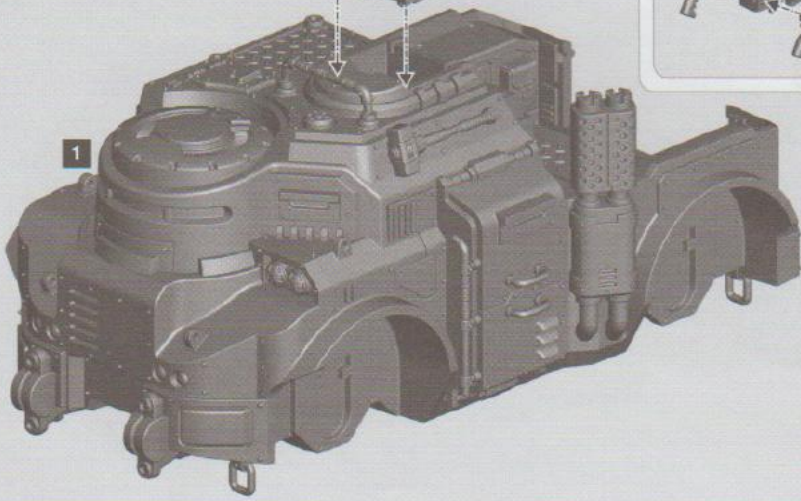
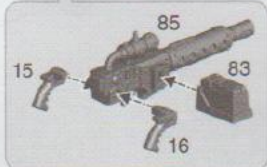
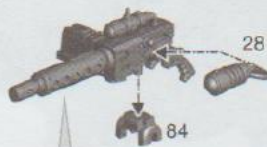
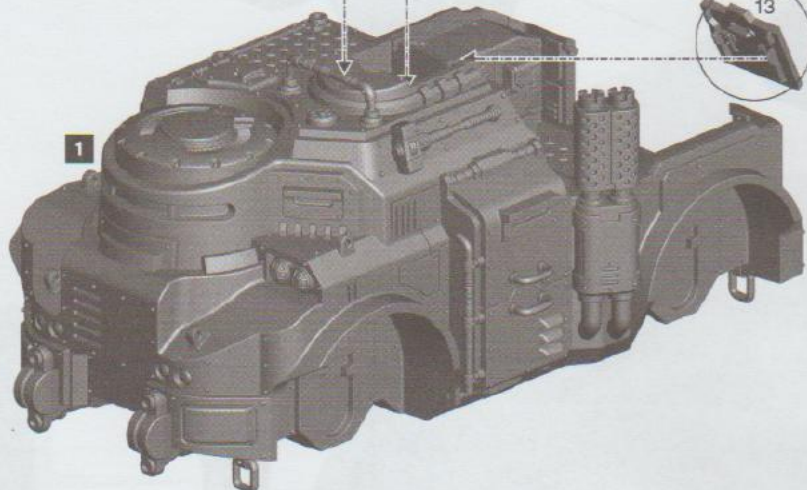
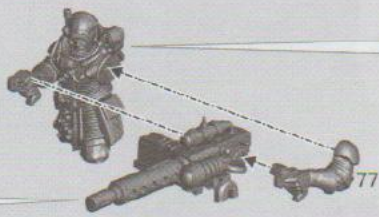

2 b

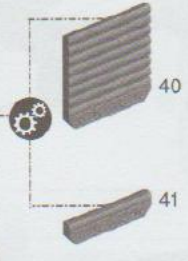
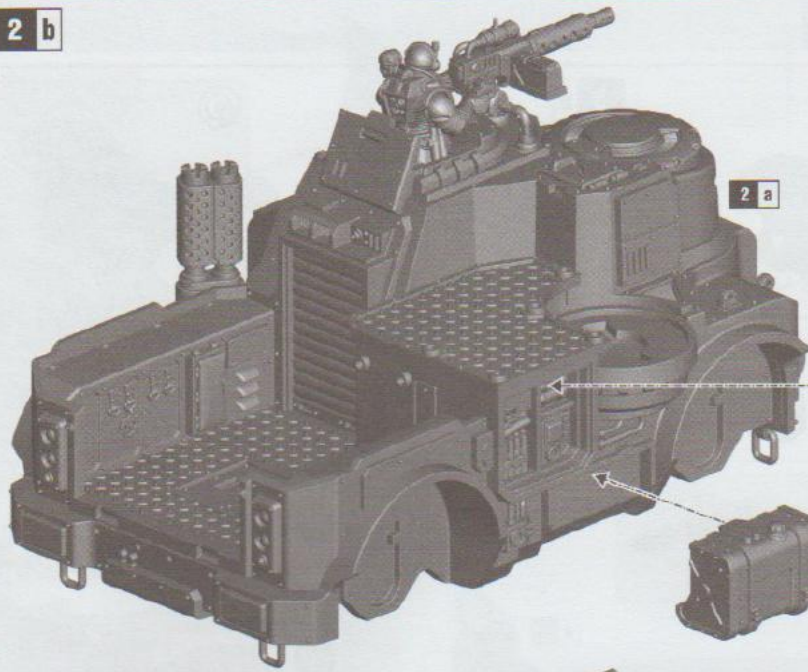

2 c

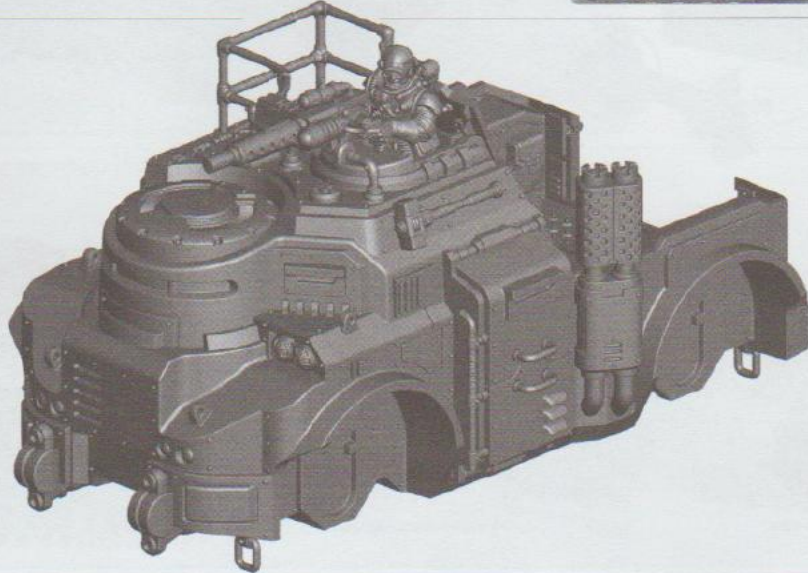
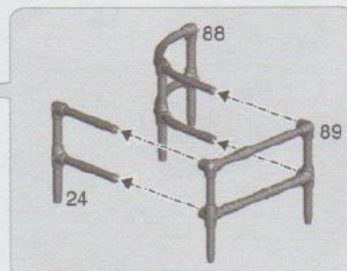
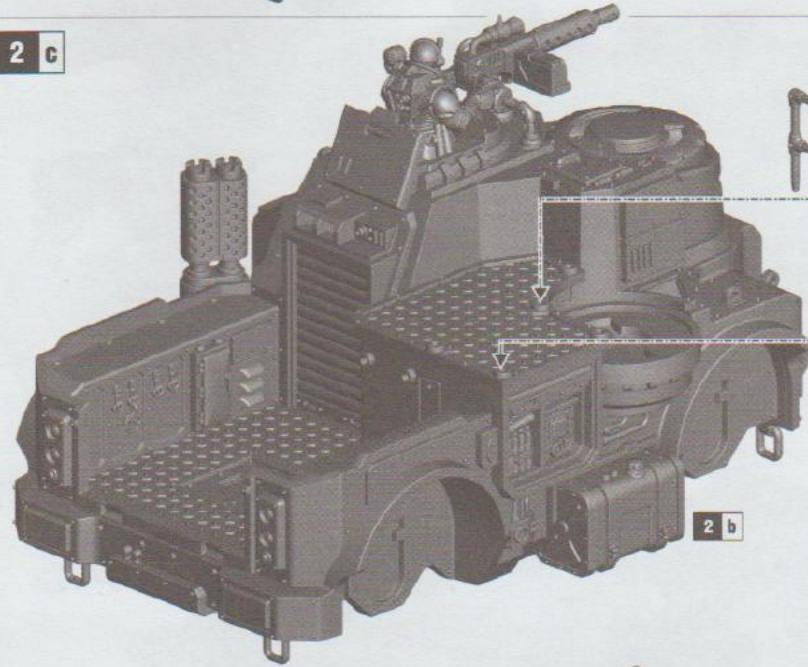

3 - 5 GOLIATH ROCKGRINDER

3 a

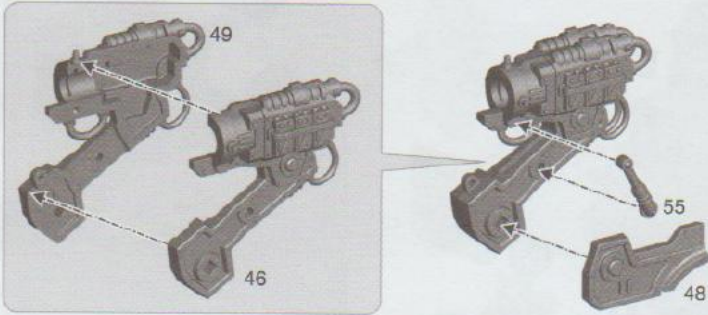

3 b

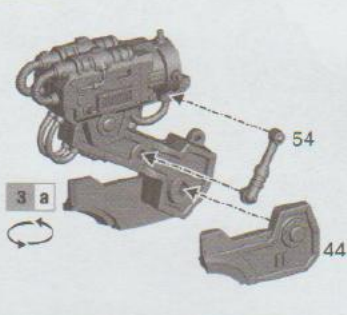

3 c

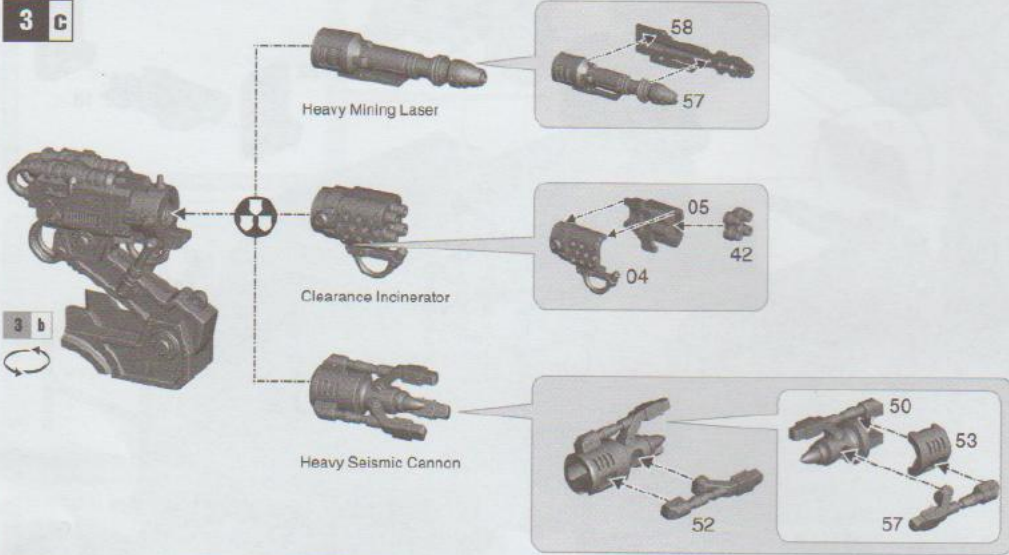

3 d

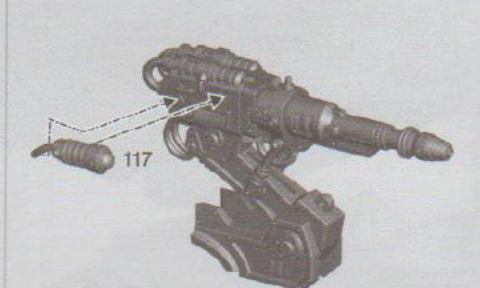
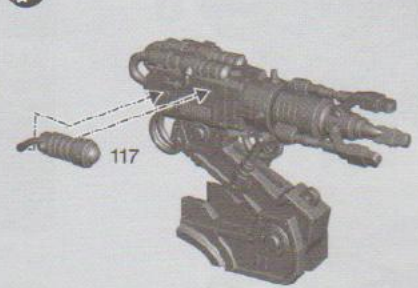
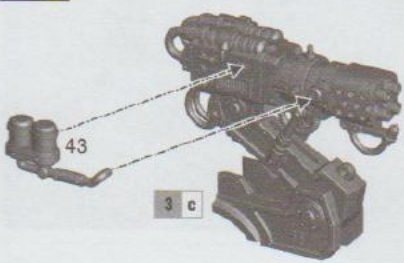

Clearance Incinerator



Heavy Seismic Cannon



Heavy Mining Laser

4 a

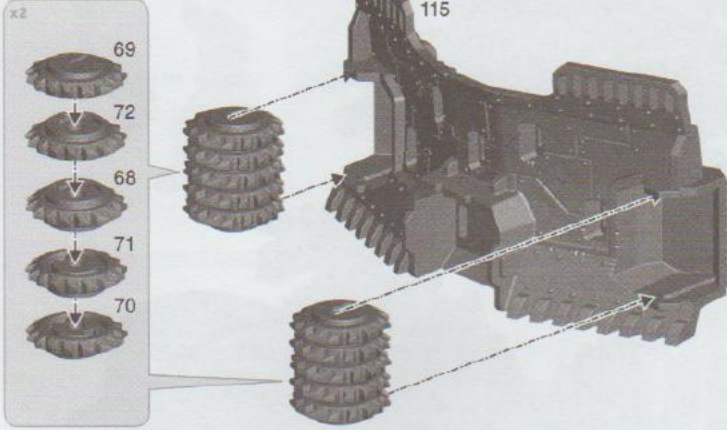

4 b

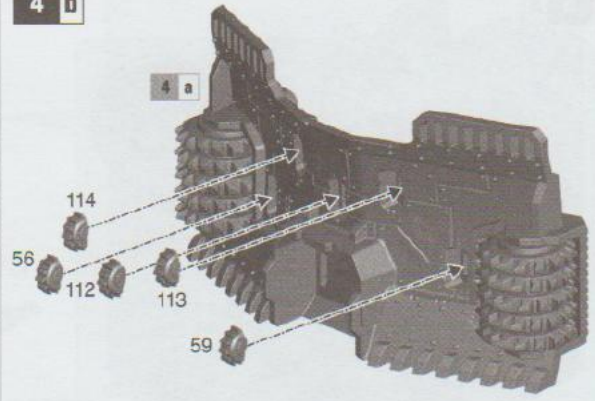

4 c

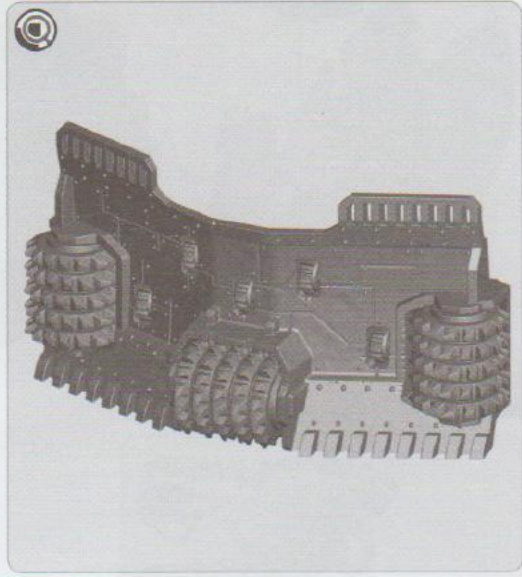
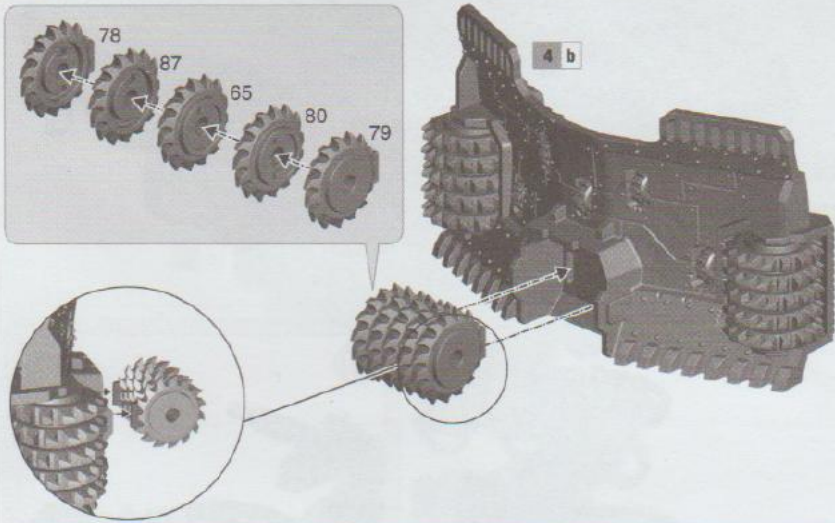

4 d

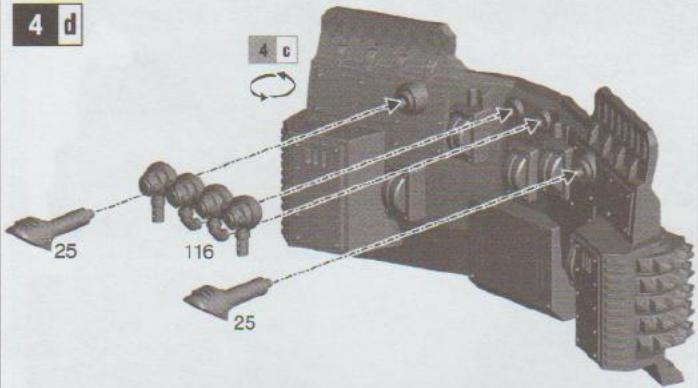

4 e

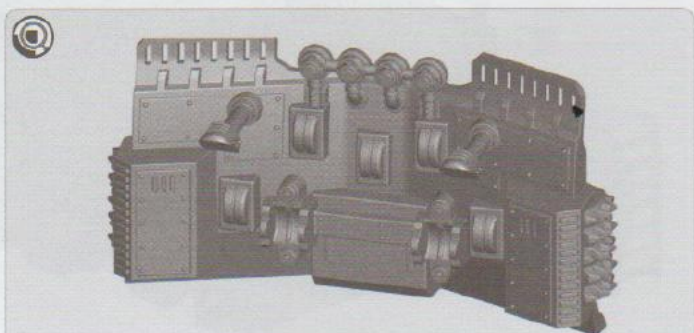
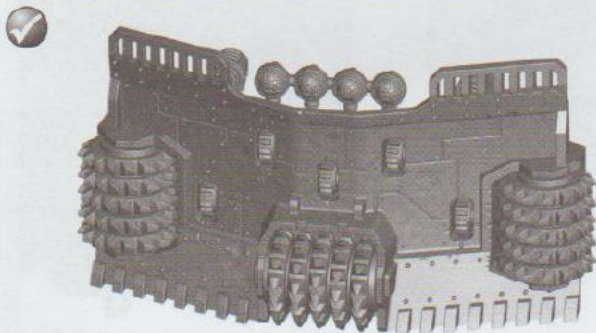
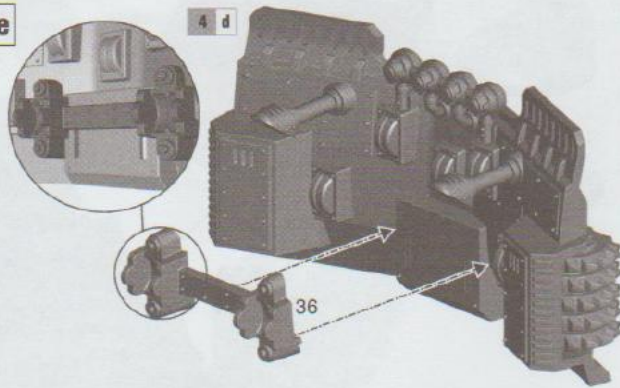

5 a

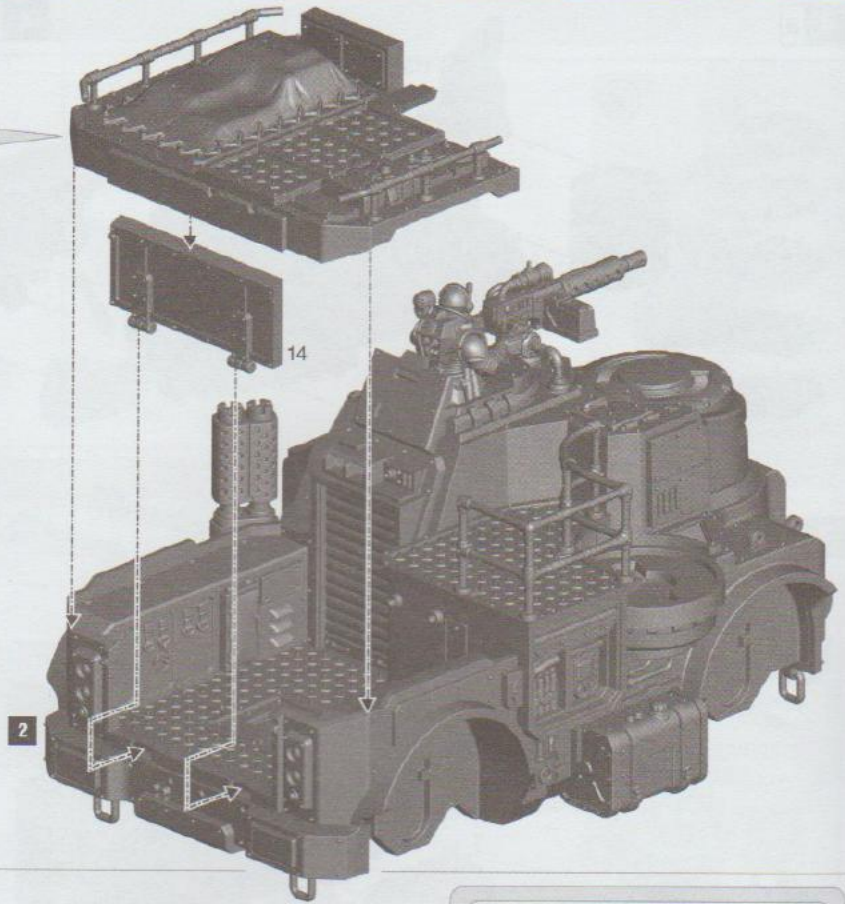
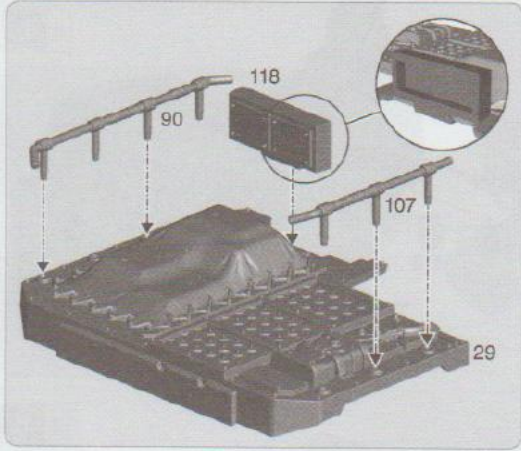

5 b



5 a

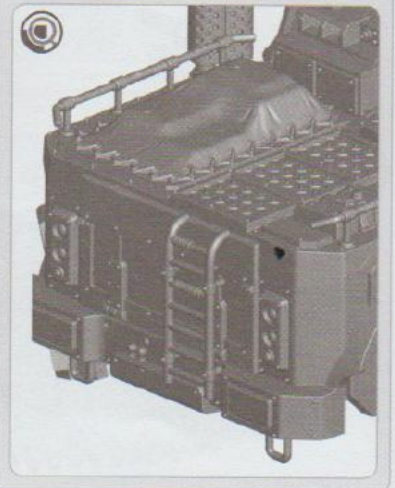
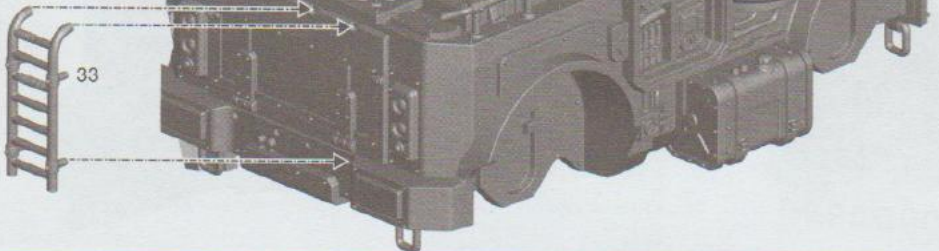

5 c

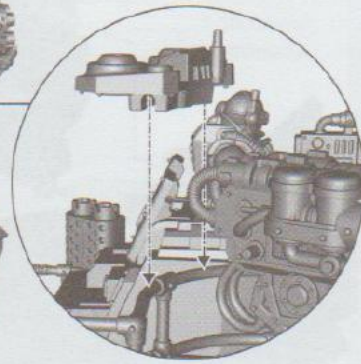
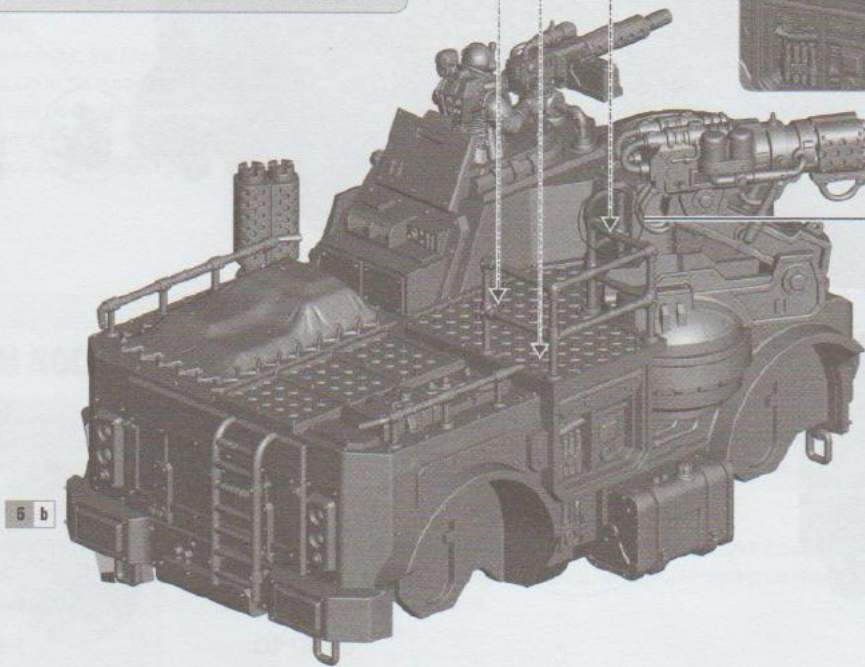
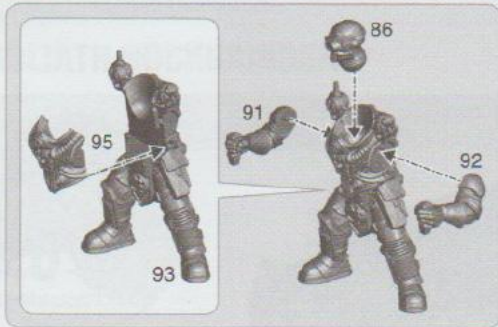

5 b

5 d

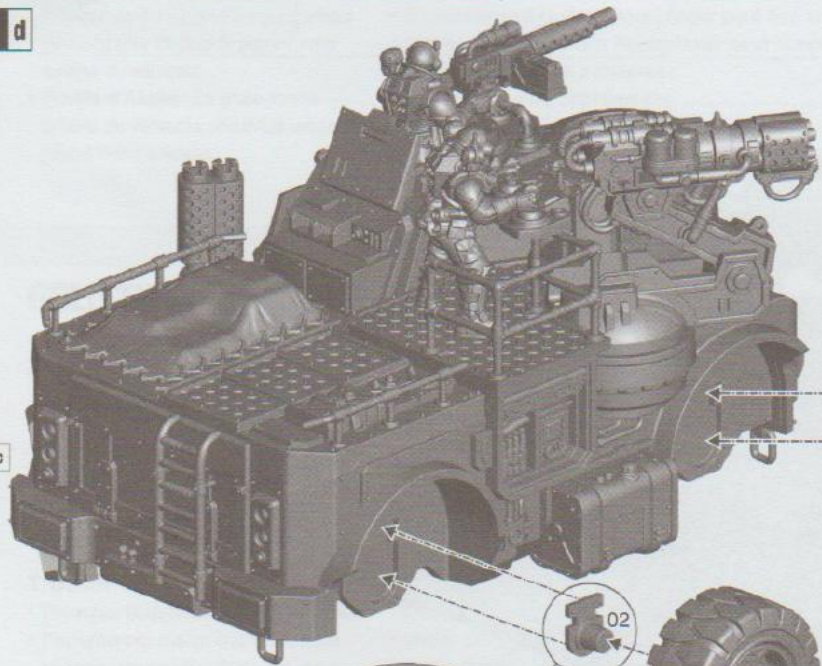

5 c



5 c

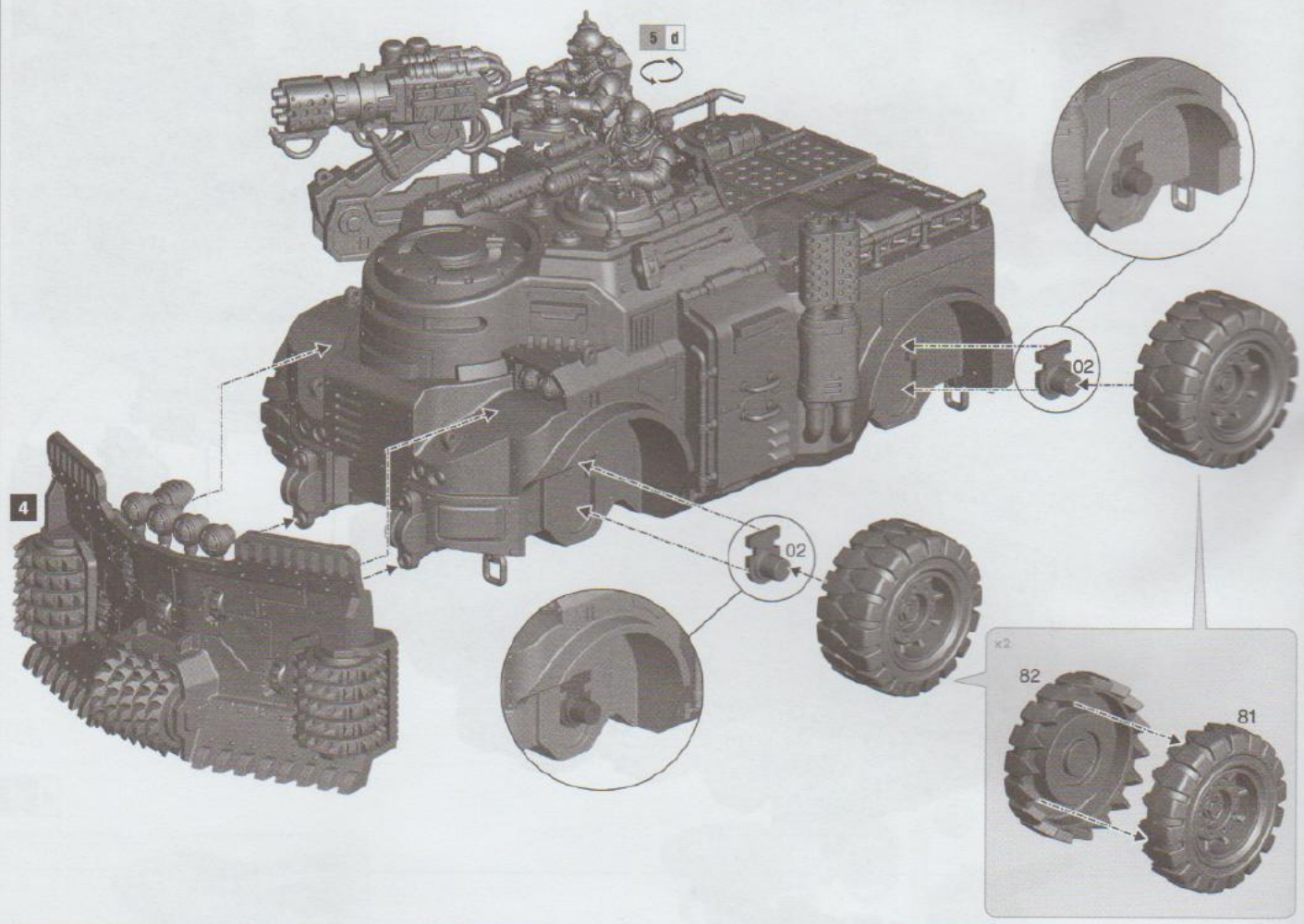

GOLIATH ROCKGRINDERS

75 POINTS

Goliath Rockgrinder	Armour					Unit Type	Unit Composition
	BS	F	S	R	HP		
	3	12	10	10	3	Vehicle (Tank, Transport)	1 Goliath Rockgrinder

WARGEAR:

- Heavy stubber
- Heavy mining laser
- Drilldozer blade

SPECIAL RULES:

Rugged Construction: If this model suffers a Crew Stunned, Crew Shaken or Immobilised result, roll a dice. On a roll of 4 or more, the vehicle ignores that result, but still loses a Hull Point as normal.

TRANSPORT:

- **Transport capacity:** Six Models.
- **Fire Points:** Up to six models can fire from its rear platform.
- **Access Points:** The vehicle's rear platform is one large Access Point.

OPTIONS:

- May include up to two additional Goliath Rockgrinders 75 pts/model
- Any Goliath Rockgrinder may be equipped with a cache of demolition charges 20 pts
- Any Goliath Rockgrinder may replace its heavy mining laser with one of the following:
 - Clearance incinerator 5 pts/model
 - Heavy seismic cannon 10 pts/model

GOLIATH ROCKGRINDERS

75 POINTS

Goliath Rockgrinder	Blindage					Type d'Unité	Composition d'Unité
	CT	Av	FI	Ar	PC		
	3	12	10	10	3	Véhicule (Char, Transport)	1 Goliath Rockgrinder

ÉQUIPEMENT:

- **Lame concasseuse**
- **Laser minier lourd**
- **Mitrailleuse**

RÈGLE SPÉCIALE:

Conception Robuste: Si cette figurine subit un résultat Équipage Secoué, Équipage Sonné ou Immobilisé, jetez un dé. Sur 4 ou plus, le véhicule ignore ce résultat, mais perd néanmoins 1 Point de Coque comme d'ordinaire.

TRANSPORT:

- **Capacité de Transport:** Six figurines.
- **Postes de Tir:** Jusqu'à six figurines peuvent tirer depuis la plate-forme arrière du véhicule.
- **Points d'Accès:** La plate-forme arrière du véhicule constitue un seul grand Point d'Accès.

OPTIONS:

- Ajouter jusqu'à deux Goliath Rockgrinders 75 pts/figurine
- N'importe quel Goliath Rockgrinder peut être équipé d'une cache de charges de démolition 20 pts
- N'importe quel Goliath Rockgrinder peut remplacer son laser minier lourd par une des armes suivantes:
 - Incinérateur de déblaiement 5 pts/figurine
 - Canon sismique lourd 10 pts/figurine

GOLIATH ROCKGRINDERS

75 PUNKTE

Goliath Rockgrinder	Panzerung					Einheitentyp	Zusammensetzung
	BF	F	S	H	RP		
	3	12	10	10	3	Fahrzeug (Panzer, Transporter)	1 Goliath Rockgrinder

AUSRÜSTUNG:

- **Maschinengewehr**
- **Schwerer Bergbaulaser**
- **Bohrdozerschaufel**

SONDERREGELN:

Robuste Konstruktion: Wenn dieses Modell ein „Crew betäubt“- , „Crew durchgeschüttelt“- oder „Lahmgelegt“-Ergebnis erleidet, wirf einen Würfel. Bei einer 4 oder mehr ignoriert das Fahrzeug das Ergebnis, verliert aber wie normal einen Rumpfpunkt.

TRANSPORT:

- **Transportkapazität:** Sechs Modelle
- **Feuerluken:** Bis zu sechs Modelle können von der Plattform am Heck schießen.
- **Zugangspunkte:** Die Plattform am Heck des Fahrzeugs ist ein großer Zugangspunkt.

OPTIONS:

- Darf bis zu zwei zusätzliche Goliath Rockgrinders enthalten 75 Pkt./Modell
- Jeder Goliath Rockgrinder darf mit Versteckten Sprengladungen ausgerüstet werden 20 Pkt.
- Jeder Goliath Rockgrinder darf seinen Schweren Bergbaulaser durch eine einzelne der folgenden Waffen ersetzen:
 - Räumungsbrenner 5 Pkt./Modell
 - Schwere Seismokanone 10 Pkt./Modell

GOLIATH ROCKGRINDER

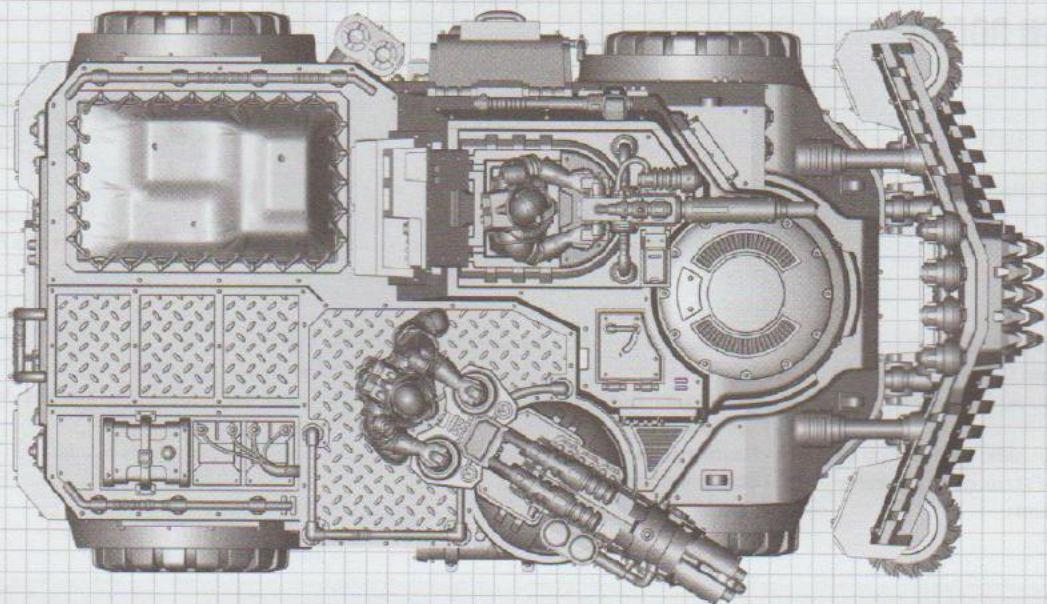
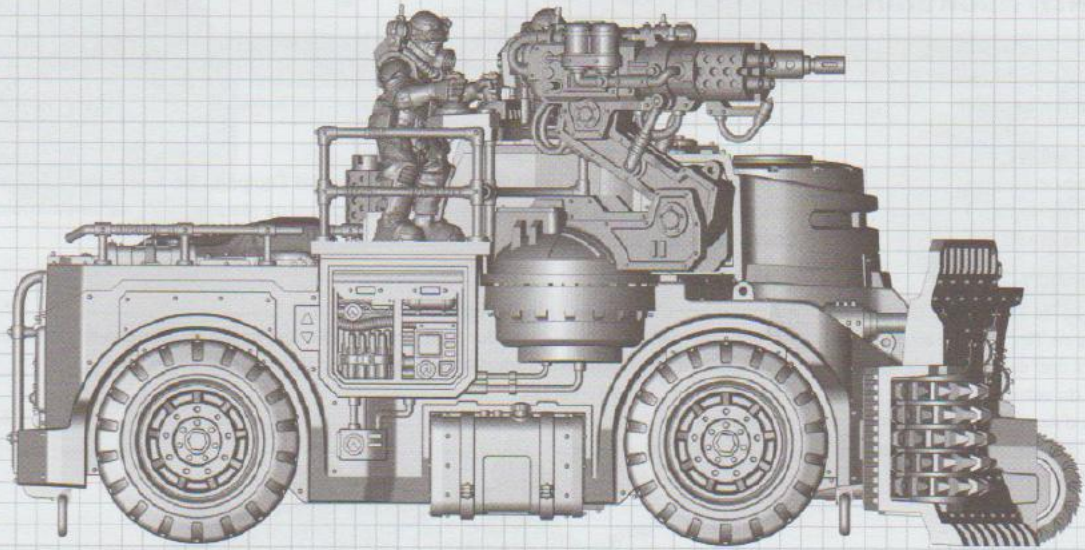
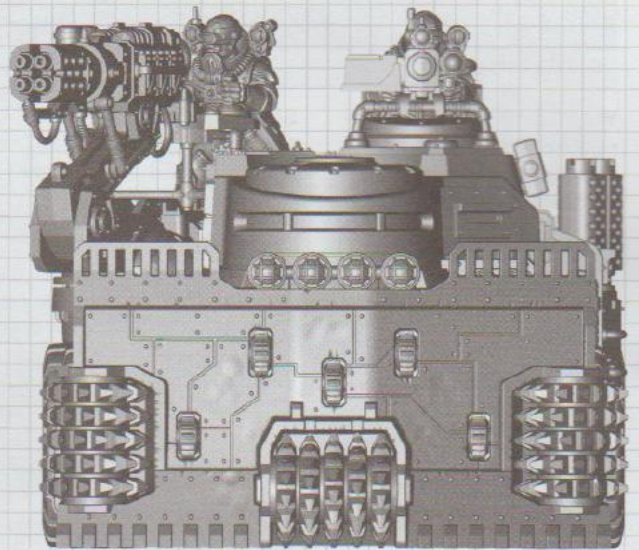
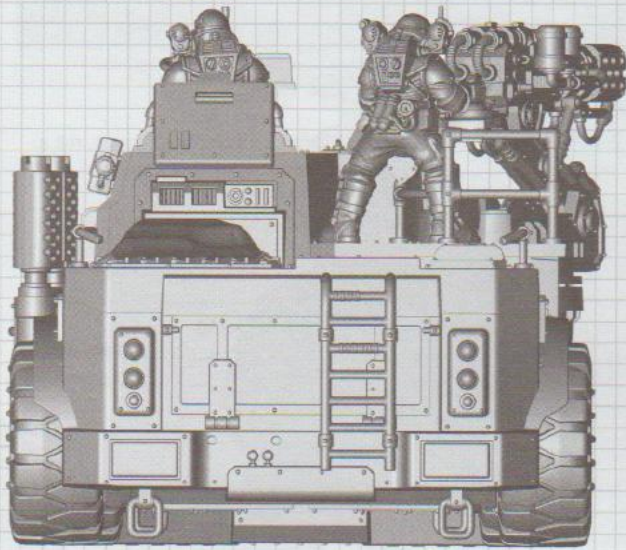

6 - 10 GOLIATH TRUCK

6 a 

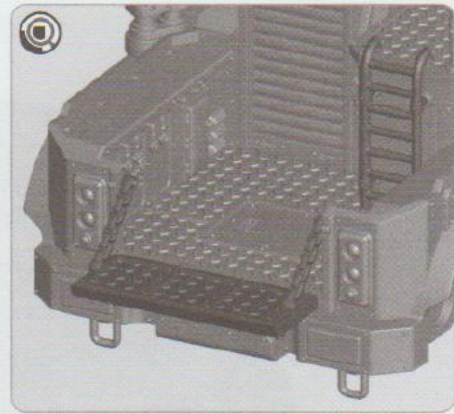
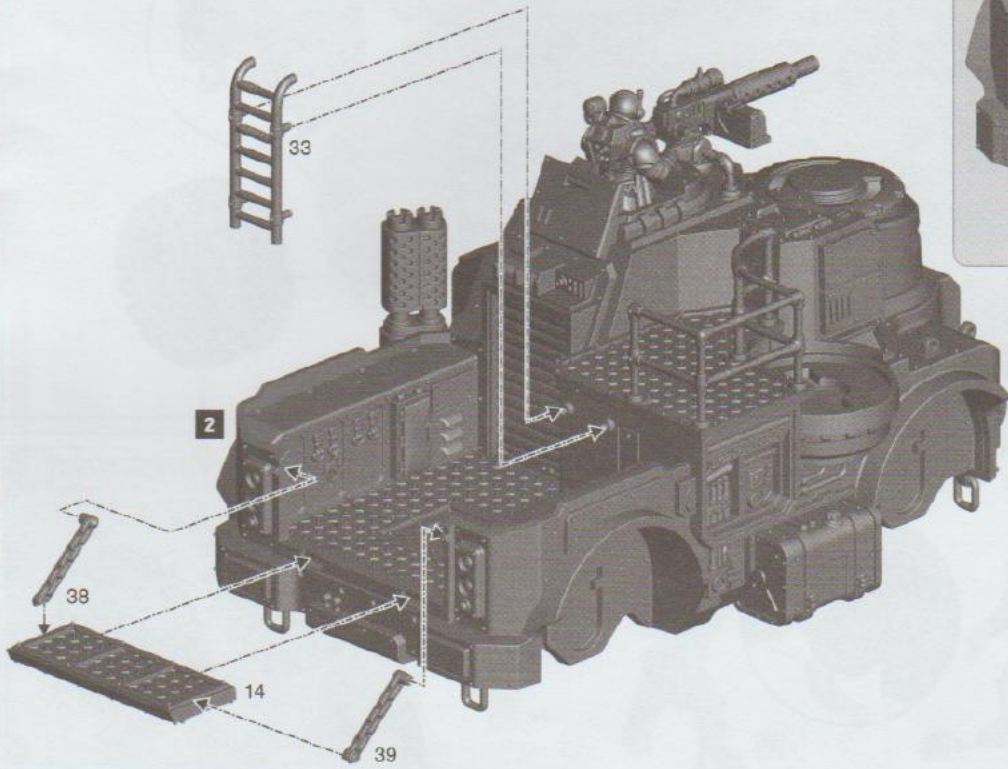

6 b

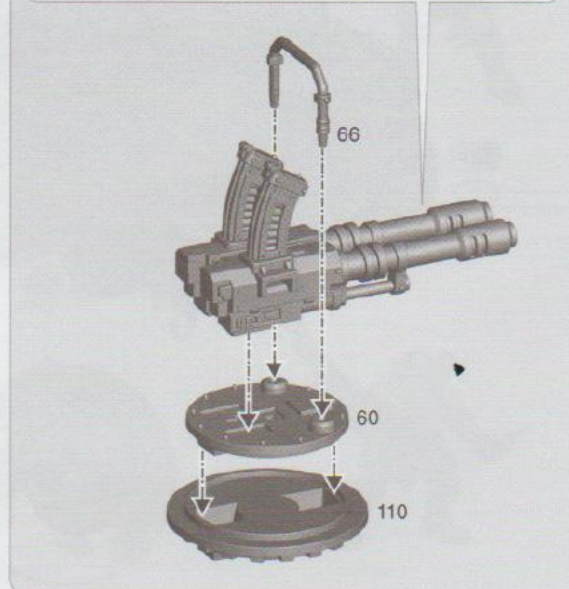
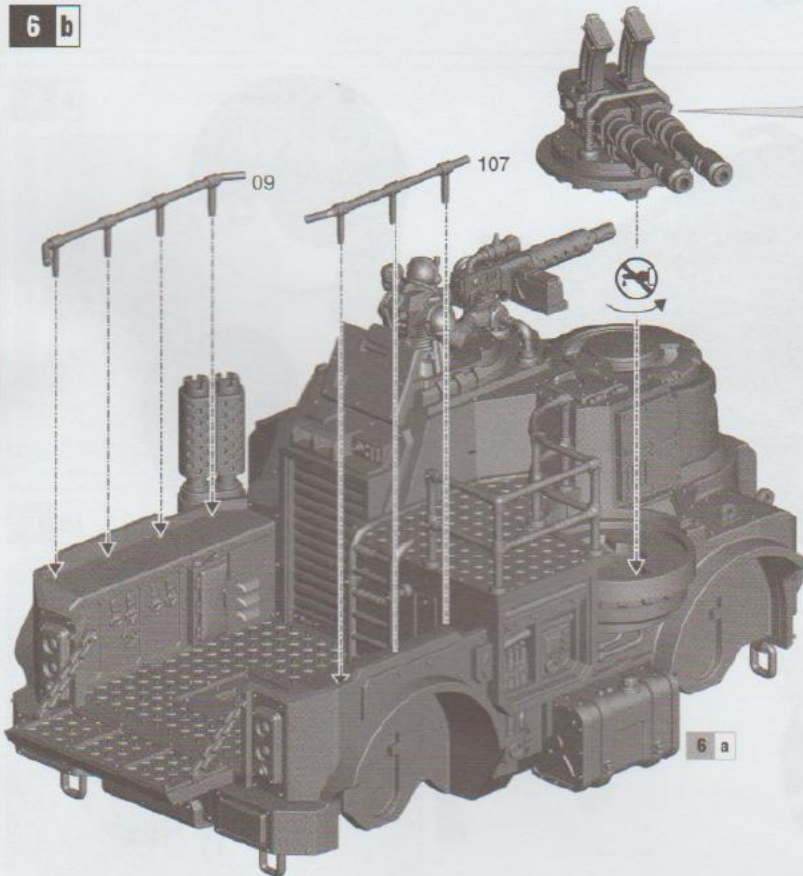

6 c

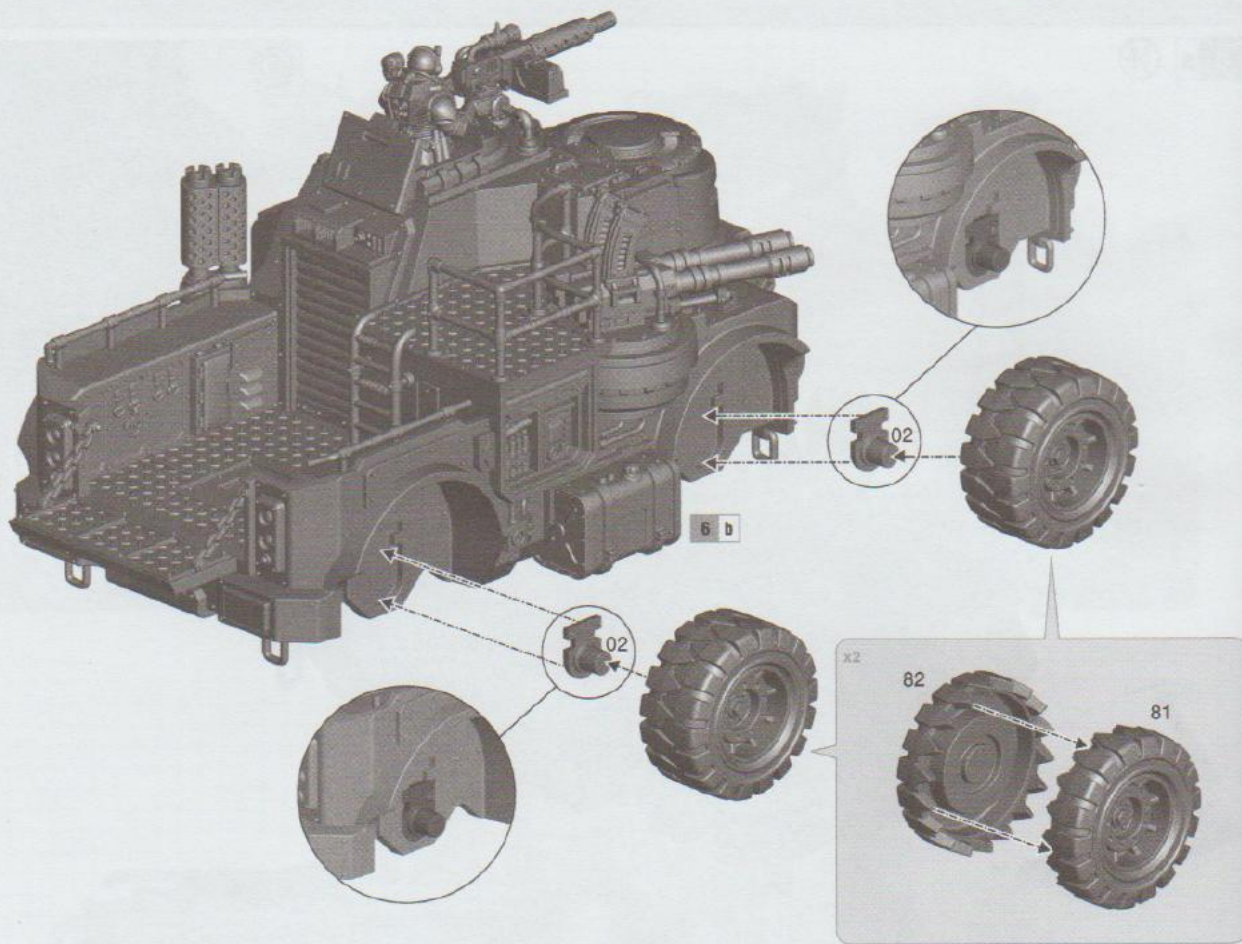

6 d

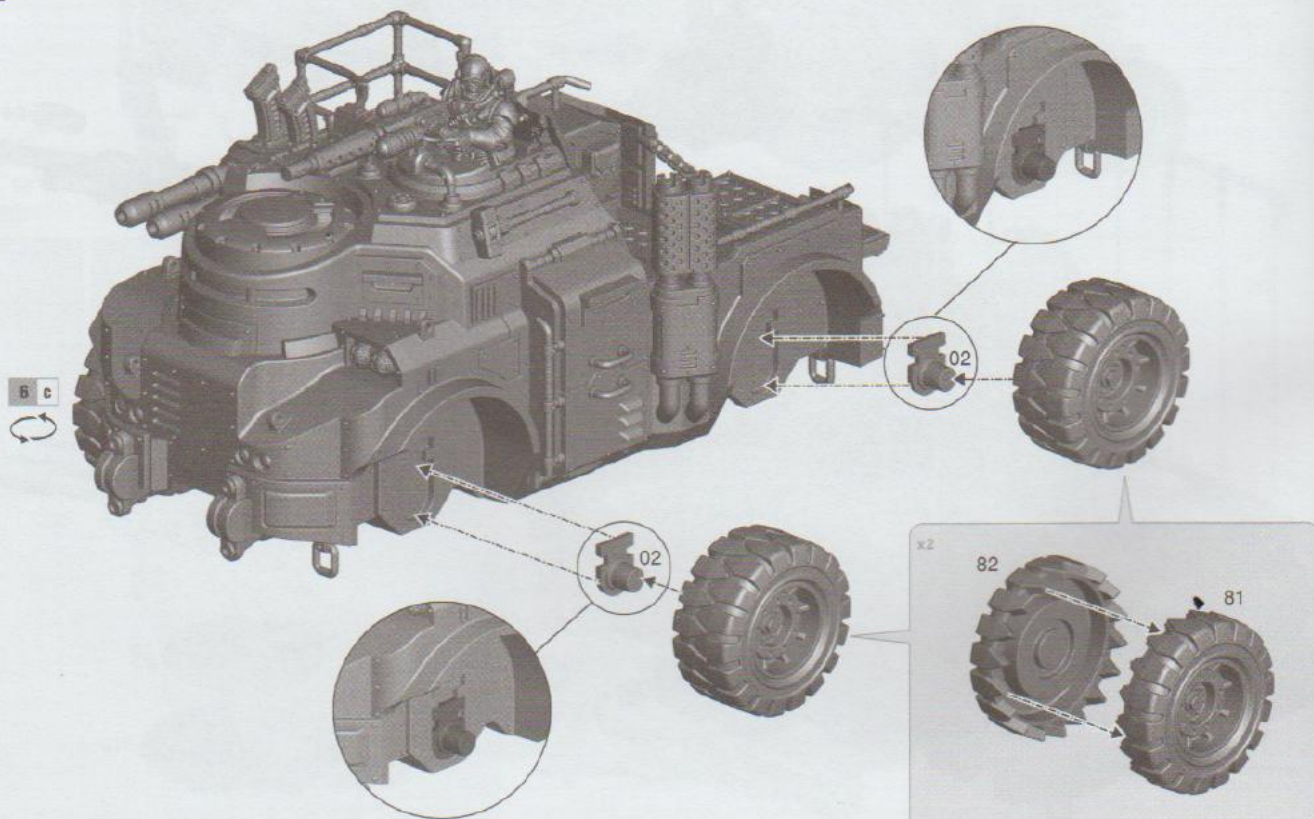

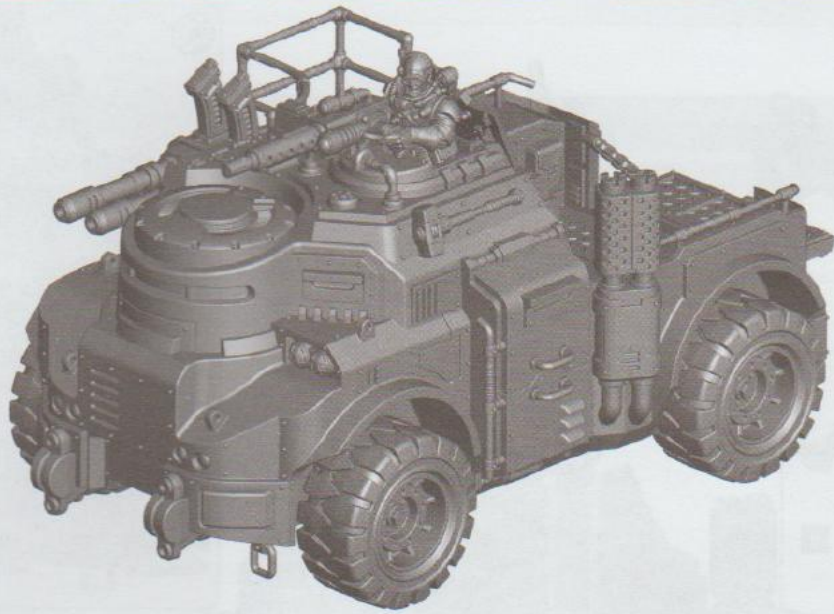

7 a



7 b



7 c



8 a



8 b

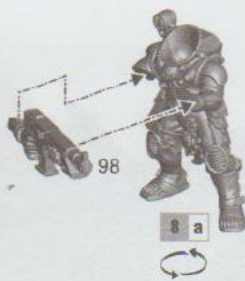

8 c



9 a

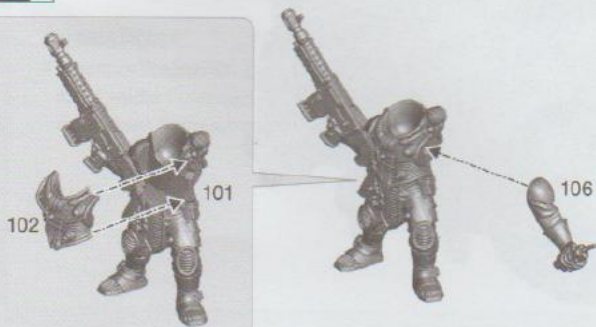

9 b



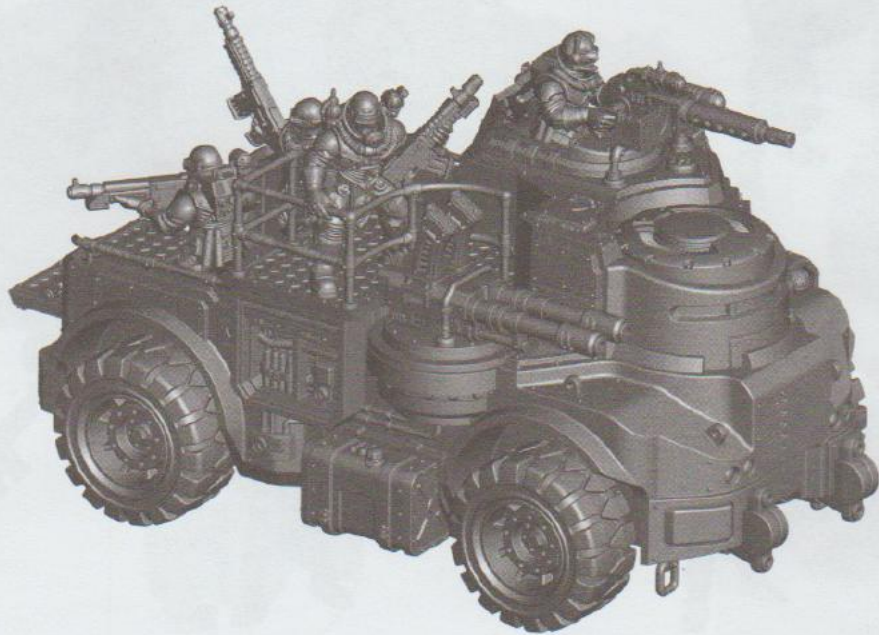

GOLIATH TRUCK

50 POINTS

Goliath Truck	┌ Armour ┐					Unit Type	Unit Composition
	BS	F	S	R	HP		
Goliath Truck	3	11	10	10	3	Vehicle (Open-topped, Transport)	1 Goliath Truck

WARGEAR:

- Heavy stubber
- Twin-linked autocannon

SPECIAL RULES:

Rugged Construction: If this model suffers a Crew Stunned, Crew Shaken or Immobilised result, roll a dice. On a roll of 4 or more, the vehicle ignores that result, but still loses a Hull Point as normal.

TRANSPORT:

- **Transport capacity:** Ten models. It cannot carry Purestrain Genestealers or a Patriarch.

OPTIONS:

- May be equipped with a cache of demolition charges 20 pts

GOLIATH TRUCK

50 POINTS

Goliath Truck	┌ Blindage ┐					Type d'Unité	Composition d'Unité
	CT	Av	Fl	Ar	PC		
Goliath Truck	3	11	10	10	3	Véhicule (Découvert, Transport)	1 Goliath Truck

ÉQUIPEMENT:

- Autocanon jumelé
- Mitrailleuse

RÈGLE SPÉCIALE:

Conception Robuste: Si cette figurine subit un résultat Équipage Secoué, Équipage Sonné ou Immobilisé, jetez un dé. Sur 4 ou plus, le véhicule ignore ce résultat, mais perd néanmoins 1 Point de Coque comme d'ordinaire.

TRANSPORT:

- **Capacité de Transport:** Dix figurines. Un Goliath Truck ne peut pas transporter de Purestrain Genestealers ni de Patriarch.

OPTIONS:

- Cache de charge de démolition 20 pts

GOLIATH TRUCK

50 PUNKTE

Goliath Truck	┌ Panzerung ┐					Einheitentyp	Zusammensetzung
	BF	F	S	H	RP		
Goliath Truck	3	11	10	10	3	Fahrzeug (Offen, Transporter)	1 Goliath Truck

AUSRÜSTUNG:

- Maschinengewehr
- Synchronisierte Maschinenkanone

SONDERREGELN:

Robuste Konstruktion: Wenn dieses Modell ein „Crew betäubt“- , „Crew durchgeschüttelt“- oder „Lahmgelegt“-Ergebnis erleidet, wirf einen Würfel. Bei einer 4 oder mehr ignoriert das Fahrzeug das Ergebnis, verliert aber wie normal einen Rumpfpunkt.

TRANSPORT:

- **Transportkapazität:** Zehn Modelle. Kann weder Purestrain Genestealers noch einen Patriarch transportieren.

OPTIONEN:

- Darf mit Versteckten Sprengladungen ausgerüstet werden 20 Pkt.

GOLIATH TRUCK

