



Free Downloads of Build Instructions,
Assembly Booklets & How To Guides

BuildInstructions.com

ATALAN JACKALS





• **READ THIS FIRST • À LIRE EN PREMIER • LEER ANTES DE MONTAR**
 • **LIES DIES ZUERST • LEGGI PRIMA QUESTO**

- **BEFORE ASSEMBLING YOUR MINIATURES PLEASE READ THROUGH THE INSTRUCTIONS IN THIS BOOKLET CAREFULLY.** A pair of plastic cutters is required to remove the plastic components in this kit from their frame. We advise using a mouldline scraping tool to clean up the parts. To assemble your model you will need plastic glue. Games Workshop sells Citadel Fine Detail Cutters, Citadel Mouldline Remover and Citadel Plastic Glue, but does not recommend these products for use by children under the age of 16 without adult supervision.
- **AVANT D'ASSEMBLER VOS FIGURINES, VEUILLEZ LIRE ATTENTIVEMENT LES INSTRUCTIONS DE CE LIVRET.** Une pince coupante est requise pour détacher chaque élément de sa grappe. Nous vous recommandons l'utilisation d'un grattoir pour ébarber les éléments. Pour l'assemblage, vous aurez également besoin de colle plastique. Games Workshop commercialise les Pinces de Précision Citadel, l'Ébarboir Citadel et la Colle Plastique Citadel, mais n'en recommande pas l'utilisation pour des enfants de moins de 16 ans sans la supervision d'un adulte.
- **POR FAVOR, LEE CUIDADOSAMENTE ESTE LIBRETO DE INSTRUCCIONES ANTES DE EMPEZAR A MONTAR LAS MINIATURAS.** Te harán falta unas tenazas para plástico a fin de separar las piezas de la matriz. También aconsejamos una herramienta para rebabas a fin de limpiar cada pieza. Para montar la miniatura necesitarás pegamento para plástico. Games Workshop vende Tenazas Citadel, Herramientas para rebabas Citadel y Pegamento para plástico Citadel, pero no recomienda estos productos a menores de 16 años sin la supervisión de un adulto.
- **VOR DEM ZUSAMMENBAU DER MINIATUREN BITTE DIE ANWEISUNGEN IN DIESER ANLEITUNG AUFMERKSAM DURCHLESEN.** Du benötigst einen Kunststoffseitenschneider, um die Kunststoffbauteile aus dem Gussrahmen herauszutrennen, und Kunststoffkleber, um die Miniatur zusammenzubauen. Außerdem empfehlen wir, die Bauteile vorher mit einem Gussgratentferner zu säubern. Games Workshop bietet Präzisions-Kunststoffseitenschneider von Citadel sowie Citadel-Kunststoffkleber an, empfiehlt aber, dass Kinder unter 16 Jahren diese nur unter Aufsicht eines Erwachsenen benutzen.
- **PRIMA DI ASSEMBLARE LE TUE MINIATURE LEGGI ATTENTAMENTE TUTTE LE ISTRUZIONI DI QUESTO LIBRETTO.** Sono necessarie un paio di tronchesine per plastica per staccare i componenti dai loro sprue. Consigliamo di usare un attrezzo apposito per pulire i componenti. Per assemblare il modello avrai bisogno di colla per plastica. Games Workshop vende Tronchesine di precisione Citadel, Attrezzo per ripulire Citadel e Colla per plastica Citadel, ma non consiglia questi prodotti ad un pubblico minore di 16 anni senza la supervisione di un adulto.

• **EXPLANATION OF SYMBOLS • EXPLICATION DES SYMBOLES • EXPLICACIÓN DE SÍMBOLOS**
 • **ERLÄUTERUNG DER SYMBOLE • LEGENDA DEI SIMBOLI**



- Special instruction - Please read
- Instructions spéciales - Lire attentivement
- Instrucción especial: Por favor, léela
- Besondere Anweisung - Bitte lesen
- Istruzioni speciali - Leggi attentamente



- Variant assembly
- Variante d'assemblage
- Variante de montaje
- Bauvariante
- Assemblaggio alternativo



- Dry fit stage before gluing
- Tester avant de coller
- Comprobar el encaje antes de pegar
- Positionierung erst ohne Klebstoff ausprobieren
- Prova a secco prima di incollare



- Repeat process
- Répéter l'étape
- Repetir pasos
- Vorgang wiederholen
- Ripeti il processo



- Choice of parts
- Choix d'éléments
- Modelos de componentes
- Auswahl an Teilen
- Scelta di componenti



- Stage complete
- Étape terminée
- Paso completado
- Schritt abgeschlossen
- Fase completa

1 - 3 ATALAN LEADER / ATALAN JACKAL 1

1 a

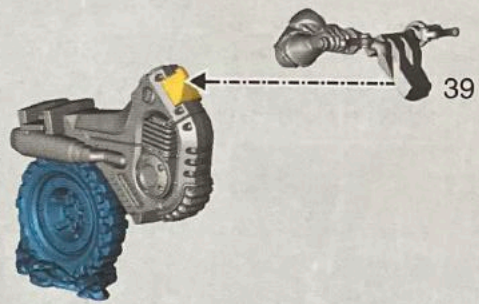
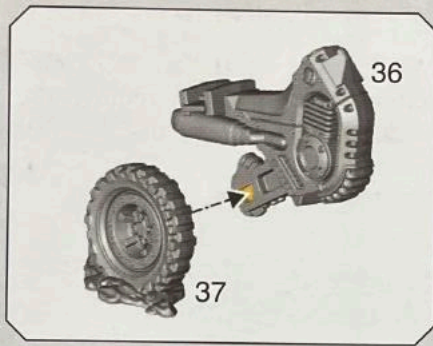

1 b

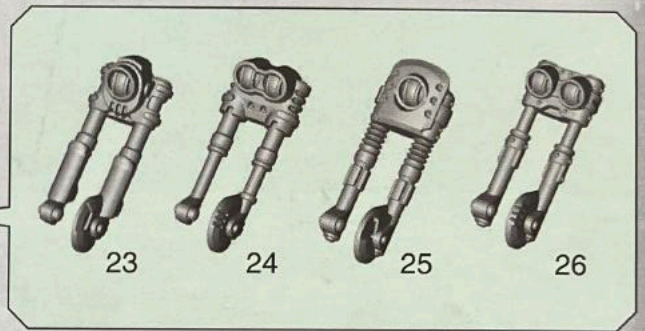
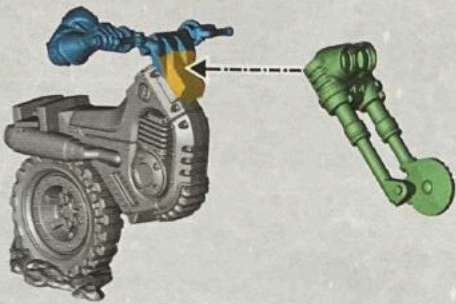

1 c

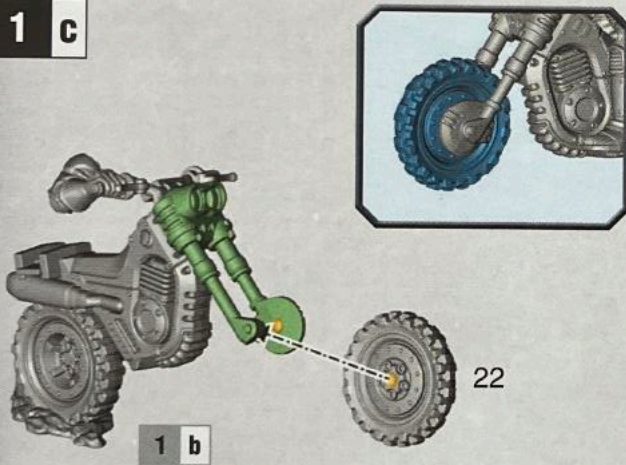

1 d

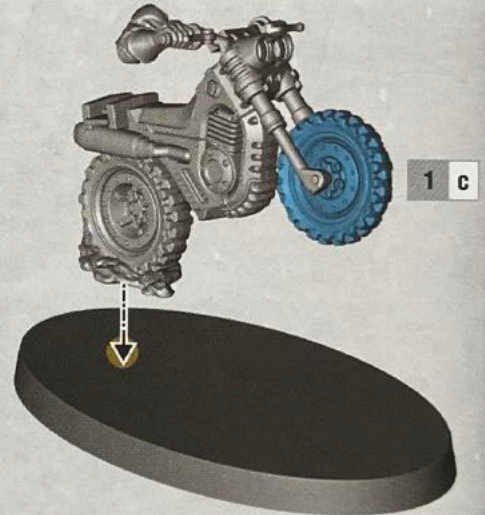

1 e

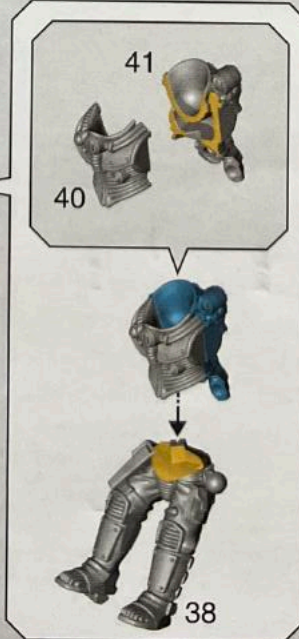
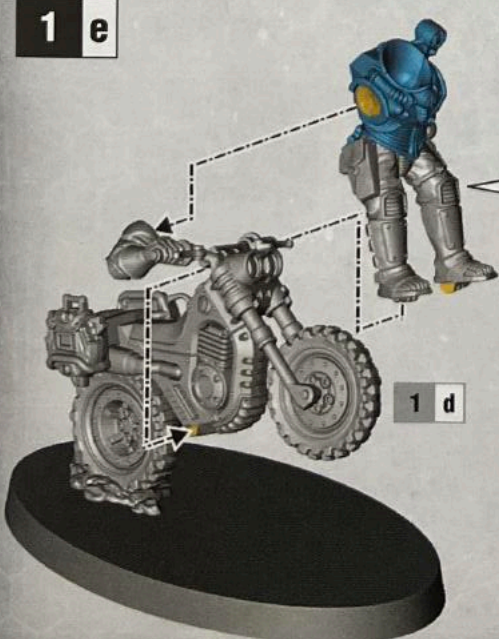



- CHOOSE THE VARIANT YOU WANT TO BUILD
- CHOISISSEZ LA VARIANTE À ASSEMBLER
- ELIGE QUÉ VERSIÓN QUIERES MONTAR
- WÄHLE DIE VARIANTE, DIE DU BAUEN MÖCHTEST
- SCEGLI LA VARIANTE CHE VUOI ASSEMBLARE

2 ATALAN LEADER



3 ATALAN JACKAL 1



2 a

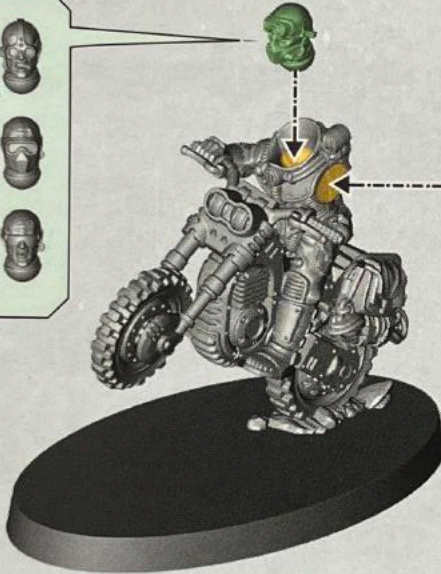
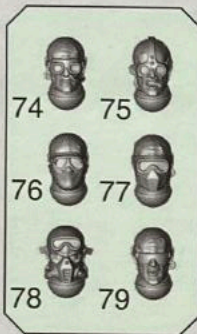

- BOLT PISTOL
- PISTOLET BOLTER
- PISTOLA BÓLTER
- BOLTPISTOLE
- PISTOLA REQUIEM

- POWER AXE
- HACHE ÉNERGÉTIQUE
- HACHA DE ENERGÍA
- ENERGIEAXT
- ASCIA POTENZIATA

- AUTOGUN
- MITRAILLEUSE
- RIFLE AUTOMÁTICO
- STURMGEWehr
- FUCILE AUTOMATICO

1



3 a

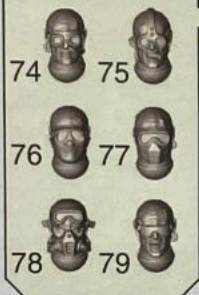

1

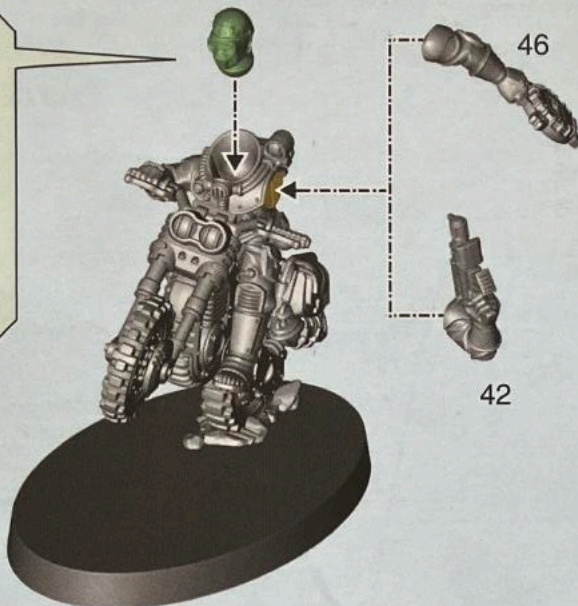

- DEMOLITION CHARGE
- CHARGE EXPLOSIVE
- CARGA EXPLOSIVA
- BERGBAUSPRENLADUNGEN
- CARICA ESPLOSIVA

- AUTOPISTOL
- PISTOLET-MITRAILLEUR
- PISTOLA AUTOMÁTICA
- MASCHINENPISTOLE
- PISTOLA AUTOMATICA



4 ATALAN JACKAL 2

4 a

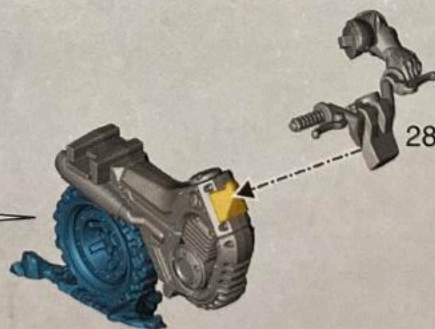
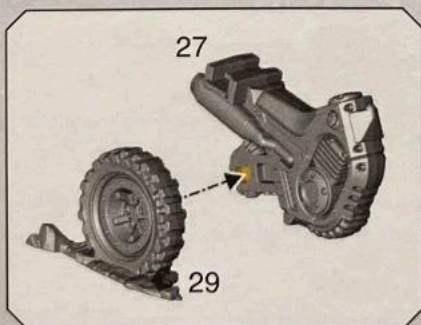

4 b

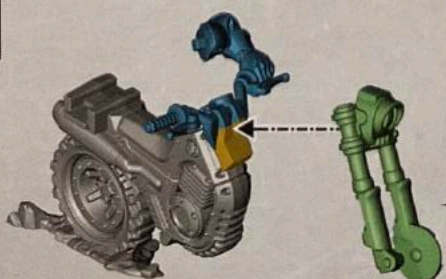

4 a

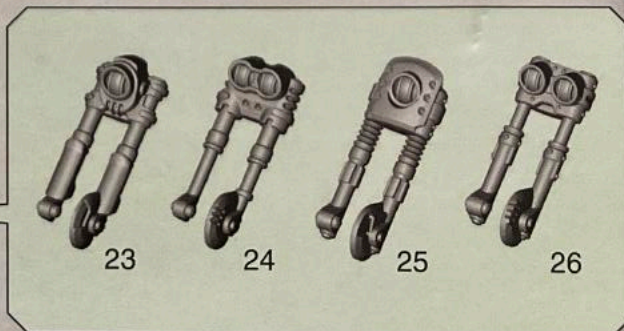

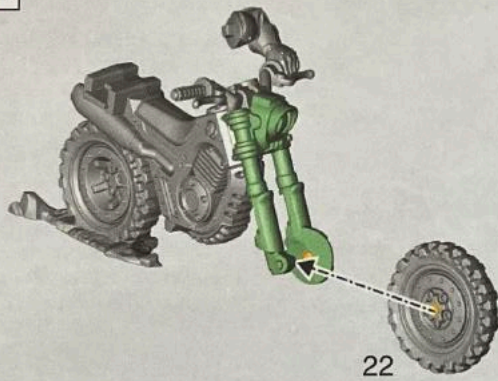
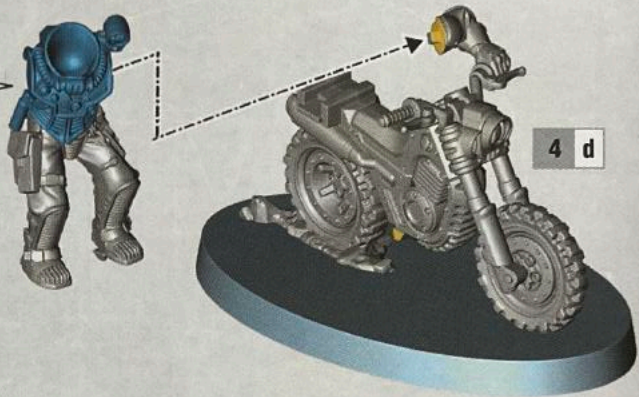
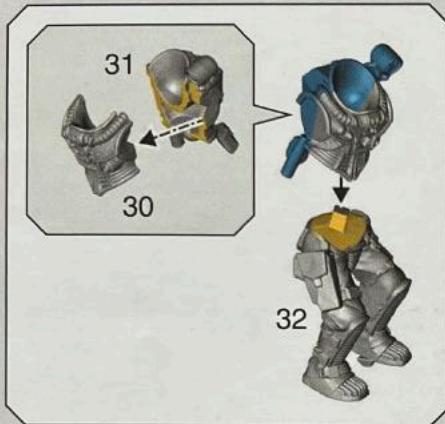
4 c**4 b****4 d****4 e****4 f**

- POWER PICK
- PIOCHE ÉNERGÉTIQUE
- PICO DE ENERGÍA
- BERGBAUHACKE
- PICCONE POTENZIATO



- AUTOPISTOL
- PISTOLET-MITRAILLEUR
- PISTOLA AUTOMÁTICA
- MASCHINENPISTOLE
- PISTOLA AUTOMATICA

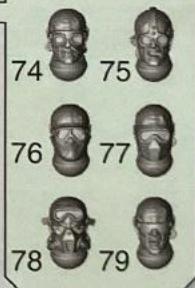
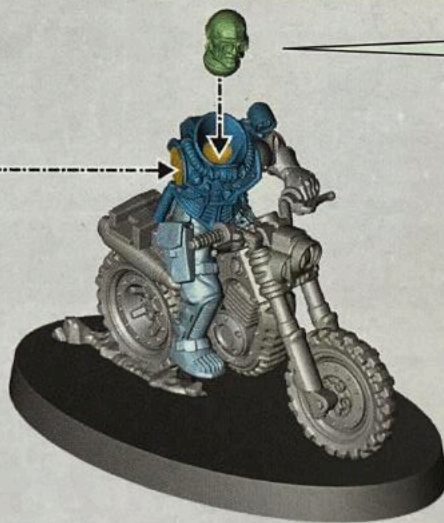

- SHOTGUN
- FUSIL À POMPE
- ESCOPETA
- SCHROTFLINTE
- FUCILE A POMPA

**4 e**

5 ATALAN JACKAL 3

5 a

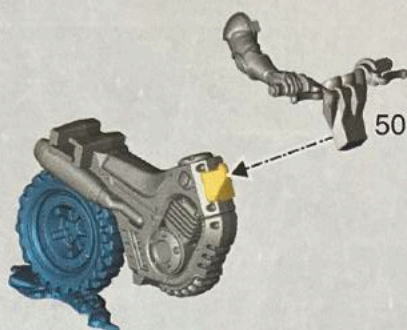
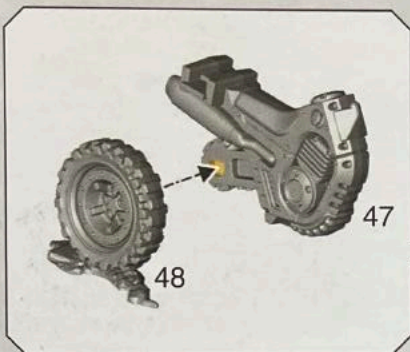

5 b

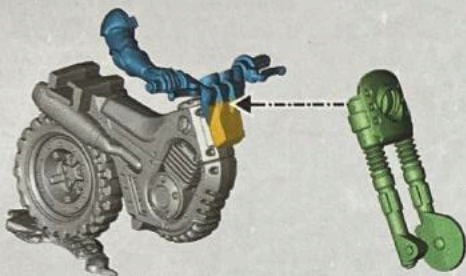

5 a

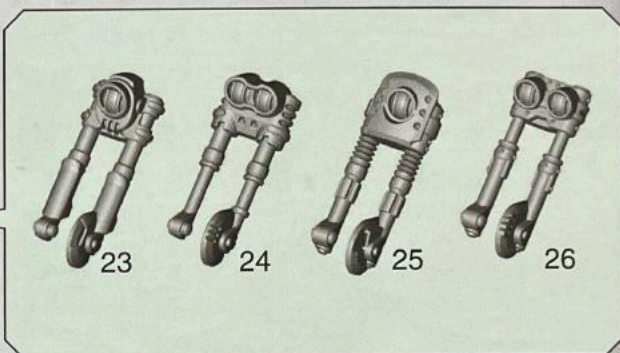

5 c

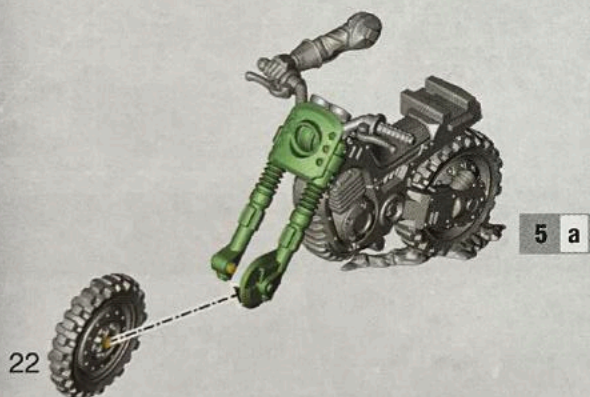

5 d

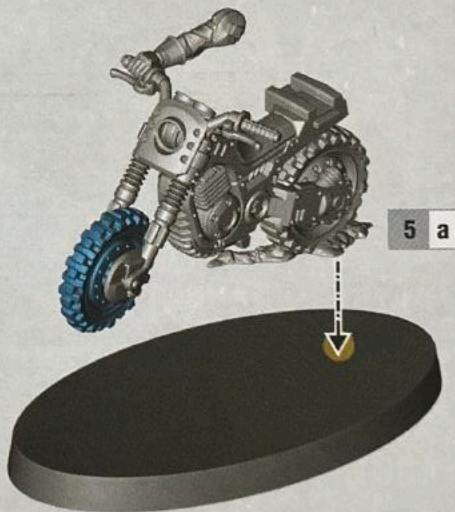

5 e

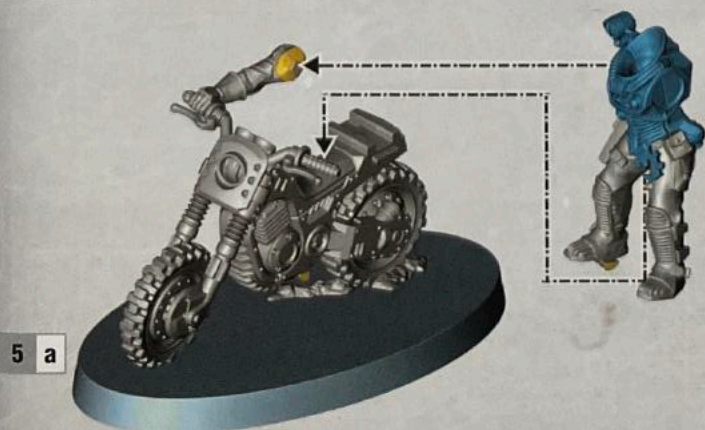

5 a

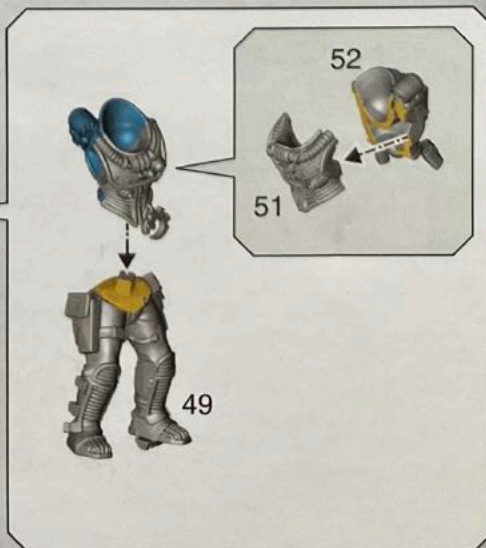

52

51

49

5 f



5 e



54



53

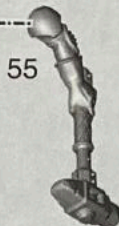

55

- SHOTGUN
- FUSIL À POMPE
- ESCOPETA
- SCHROTELINTE
- FUCILE A POMPA

- AUTOPISTOL
- PISTOLET-MITRAILLEUR
- PISTOLA AUTOMÁTICA
- MASCHINENPISTOLE
- PISTOLA AUTOMATICA

- POWER HAMMER
- MARTEAU ÉNERGÉTIQUE
- MARTILLO DE ENERGÍA
- BERGBAUHAMMER
- MARTELLO POTENZIATO

5 g



5 f



80



81



82



83



6 ATALAN JACKAL 4

6 a

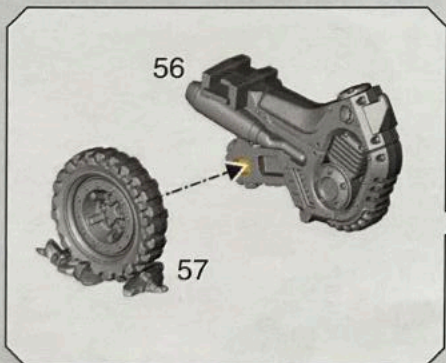

56



57

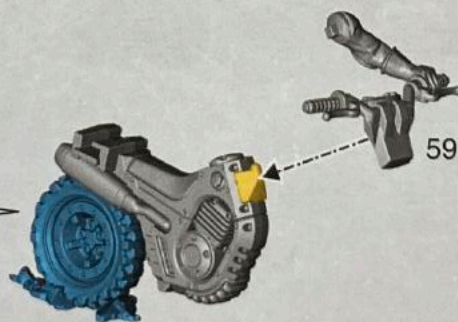

59

6 b

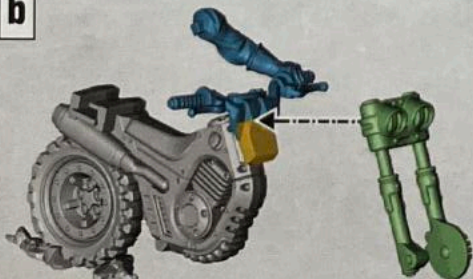

6 a



23



24



25

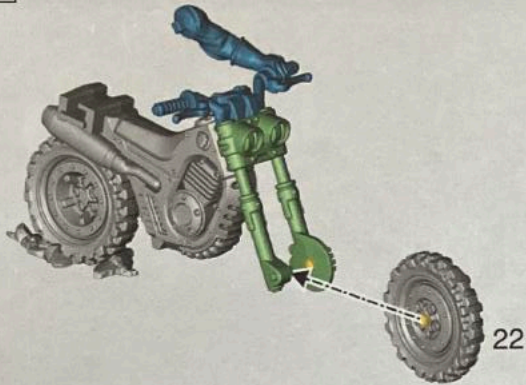
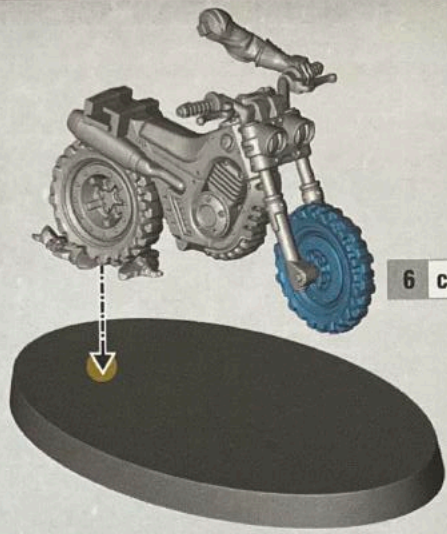

26

6 c**6 b****6 d****6 c****6 e**

61

60

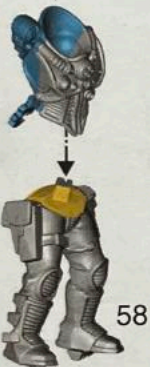
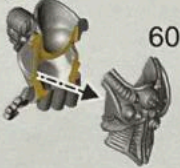

58

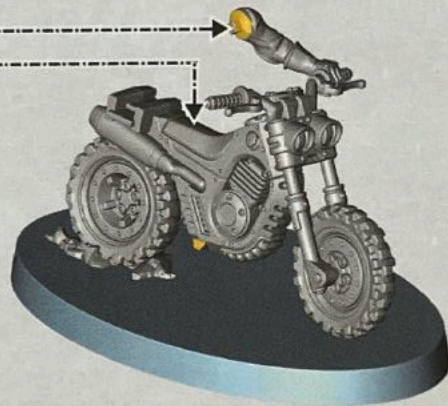
**6 d****6 f**

- GRENADE LAUNCHER
- LANCE-GRENADES
- LANZAGRANADAS
- GRANATWERFER
- LANCIAGRANATE

- IMPROVISED WEAPON
- ARME IMPROVISÉE
- ARMA IMPROVISADA
- IMPROVISIERTE WAFFE
- ARMA IMPROVVISATA

- AUTOPISTOL
- PISTOLET-MITRAILLEUR
- PISTOLA AUTOMÁTICA
- MASCHINENPISTOLE
- PISTOLA AUTOMATICA

63



64



62

**6 e**

6 g



6 f



7 a

x4

66



- CULTIST KNIFE
- POIGNARD DE CULTISTE
- CUCHILLO DE CULTIST
- CULTIST-MESSER
- COLTELLO DEI CULTISTI

68



- DEMOLITIONS CHARGE
- CHARGE EXPLOSIVE
- CARGA DE DEMOLICIÓN
- SPRENGLADUNG
- CARICA DA DEMOLIZIONE

72



- POWER PICK
- PIOCHE ÉNERGÉTIQUE
- PICO DE ENERGÍA
- BERGBAUHACKE
- PICCONE POTENZIATO

71



- SHOTGUN
- FUSIL À POMPE
- ESCOPETA
- SCHROTFLINTE
- FUCILE A POMPA

70

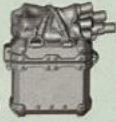

73



69



67



- STOWAGE • SACOCHES • BULTOS • LADUNG • BISACCE

2-6



8 a

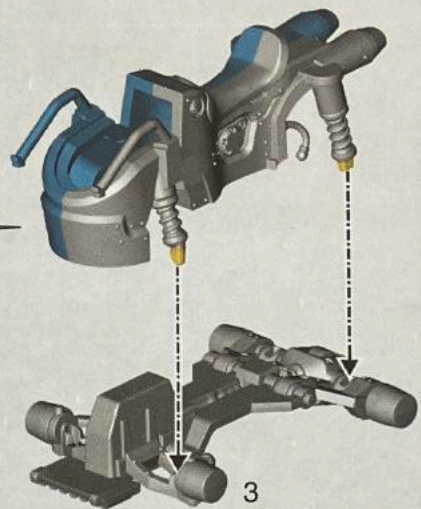
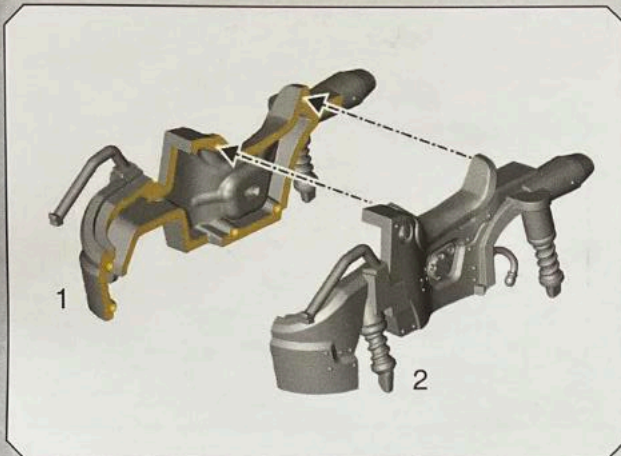

8 b

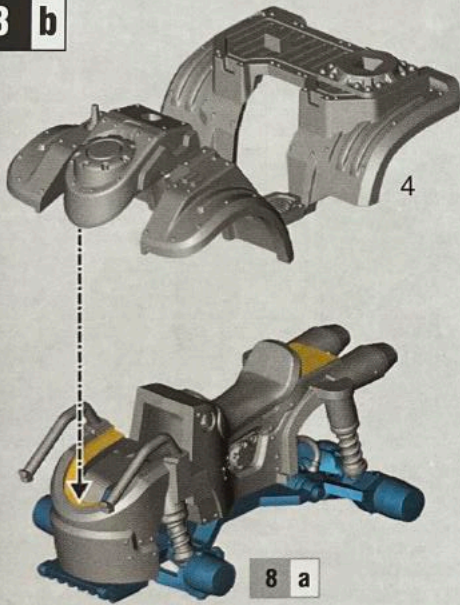

8 c

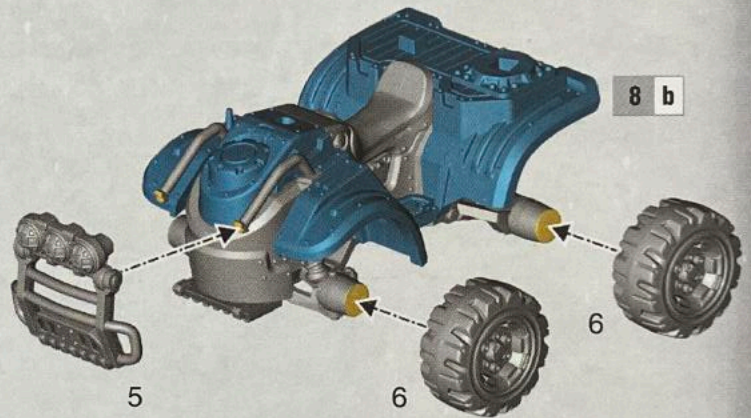

8 d

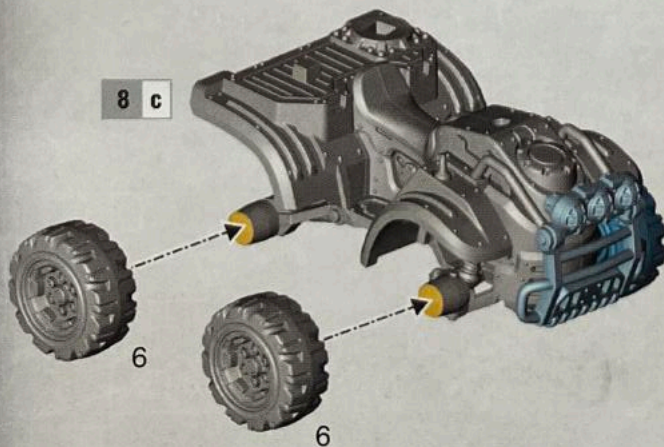

8 e

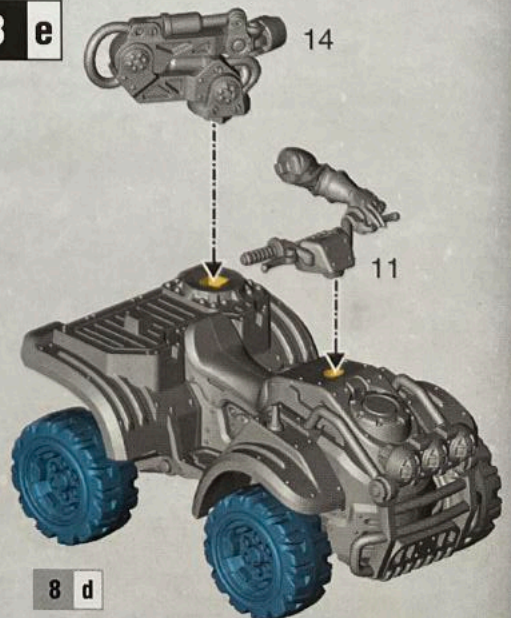

8 f

ATALAN INCINERATOR

- INCINÉRATEUR ATALAN • INCINERADOR ATALAN
- ATALAN-BRENNER • INCENERITORE ATALAN

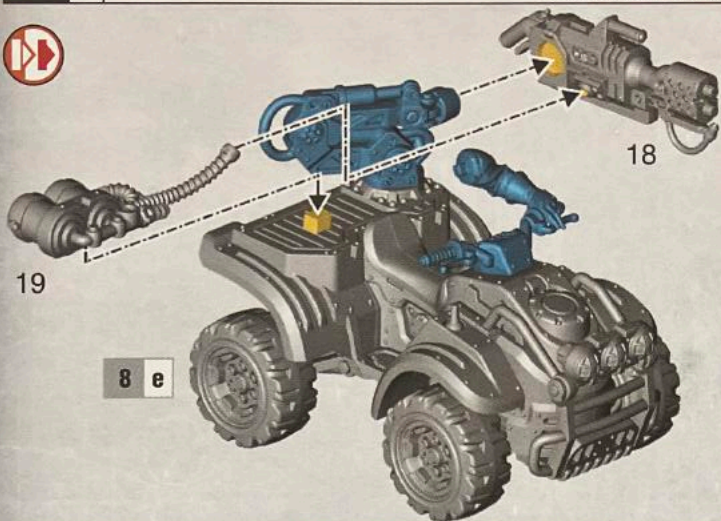

MINING LASER

- LASER MINIER • LÁSER DE MINERÍA
- BERGBAULASER • LASER MINATORE

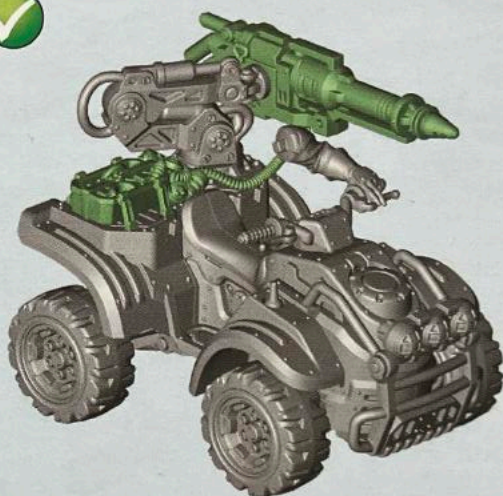
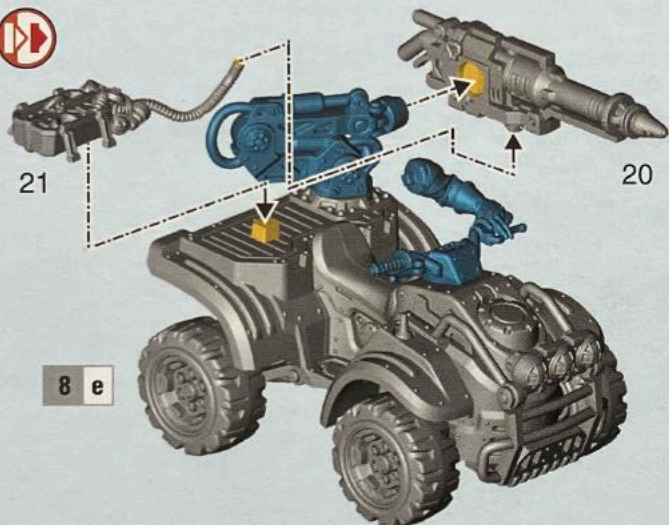

HEAVY STUBBER

- MITRAILLEUSE • AMETRALLADORA PESADA
- MASCHINENGEWEHR • MITRAGLIATORE PESANTE

17

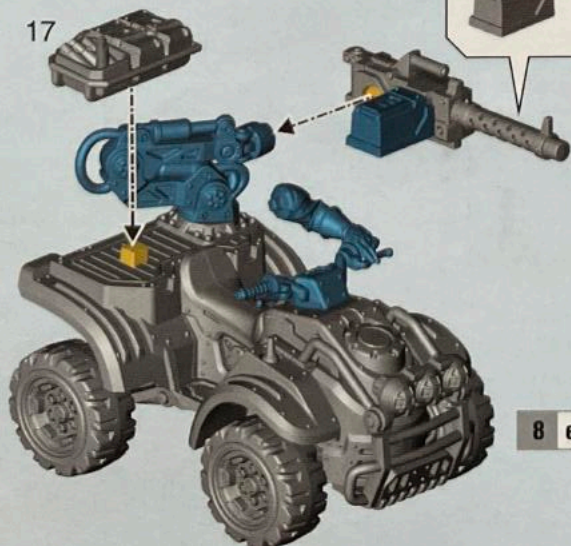

16

15

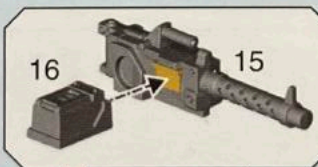

8 g

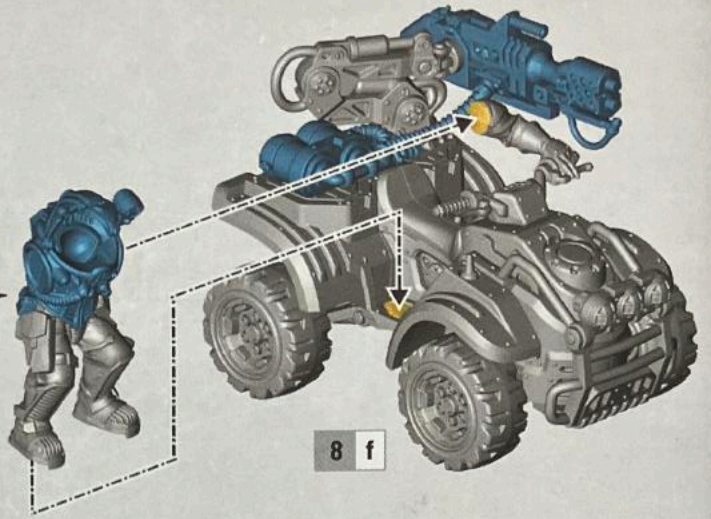
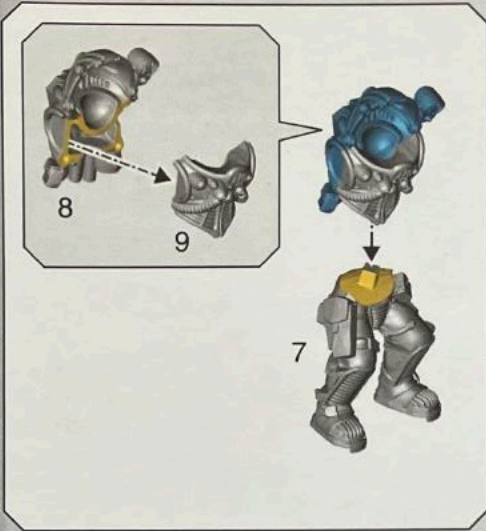

8 h

IMPROVISED WEAPON
 ARME IMPROVISÉE
 ARMA IMPROVISADA
 IMPROVISIERTE WAFFE
 ARMA IMPROVVISATA

BLASTING CHARGES
 CHARGE EXPLOSIVE
 CARGA EXPLOSIVA
 BERGBAUSPRENG-
 LADUNGEN
 CARICHE ESPLOSIVE

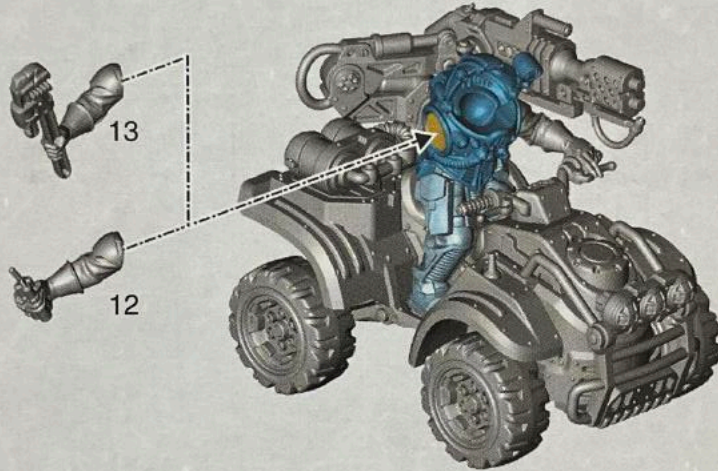

8 g

8 i

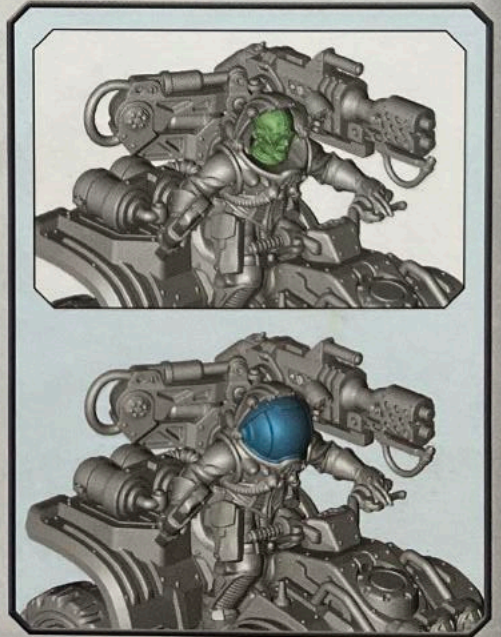
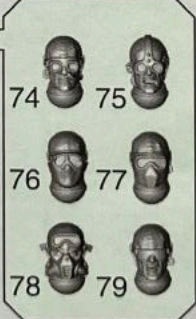
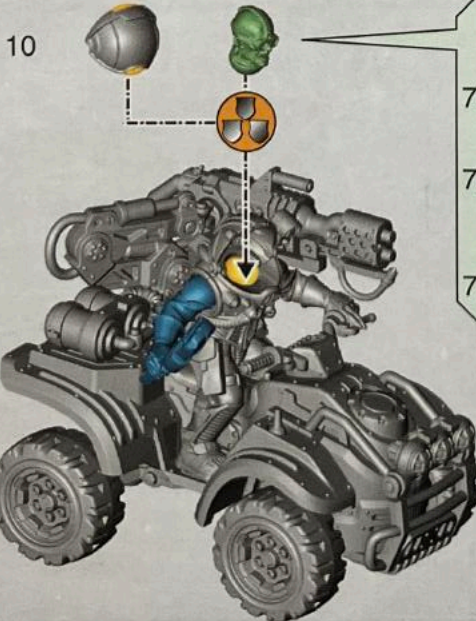

8 h

8 k

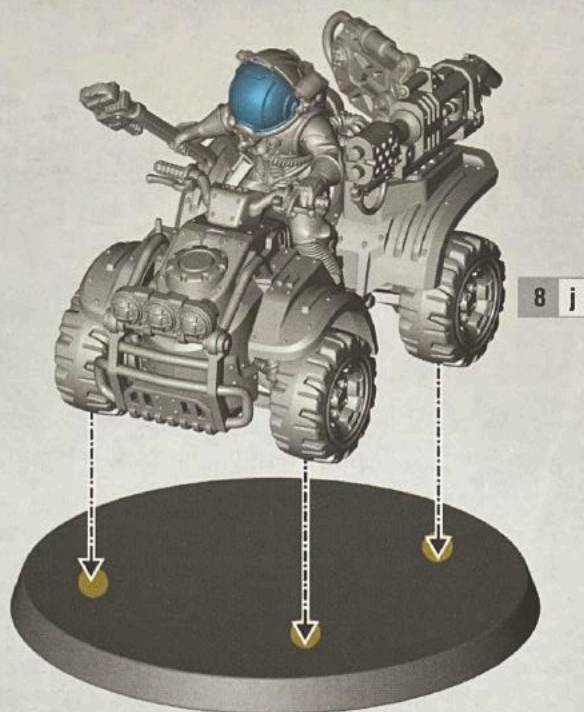

ATALAN JACKALS



NAME	M	WS	BS	S	T	W	A	Ld	Sv
Atalan Jackal	14"	4+	4+	3	4	2	1	7	5+
Atalan Leader	14"	4+	4+	3	4	2	2	8	5+
Atalan Wolfquad	14"	4+	4+	3	4	4	1	7	5+

This unit contains 1 Atalan Leader and 3 Atalan Jackals. It can include 4 additional Atalan Jackals (**Power Rating +3**) or 8 additional Atalan Jackals (**Power Rating +6**). For every four Atalan Jackals and/or Atalan Leaders in the unit, it can include 1 Atalan Wolfquad (**Power Rating +2 per model**). Each model is armed with an autopistol and blasting charges. Each Atalan Wolfquad is also equipped with a heavy stubber.

WEAPON	RANGE	TYPE	S	AP	D	ABILITIES
Atalan incinerator	12"	Heavy D6	5	-1	1	This weapon automatically hits its target.
Autopistol	12"	Pistol 1	3	0	1	-
Heavy stubber	36"	Heavy 3	4	0	1	-
Mining laser	24"	Heavy 1	9	-3	D6	-
Shotgun	12"	Assault 2	3	0	1	If the target is within half range, add 1 to this weapon's Strength.
Improvised weapon	Melee	Melee	User	0	1	-
Power pick	Melee	Melee	User	-2	D3	Each time a model with a rending claw makes an attack with this weapon, it can make one additional attack with its rending claw.
Blasting charge	6"	Grenade D6	3	0	1	-

WARGEAR OPTIONS

- The Atalan Leader and each Atalan Jackal must take two weapons from the *Atalan Weapons* list. The same model cannot take the same weapon twice. Only one in every four of these models can take a grenade launcher, and only the Atalan Leader can take an autogun, bolt pistol or power axe.
- Any Atalan Wolfquad can take one of the following: autopistol, shotgun, improvised weapon or power pick.
- Any Atalan Wolfquad can replace its heavy stubber with a mining laser or Atalan incinerator.

ABILITIES

Cult Ambush, Unquestioning Loyalty

Skilled Outriders: Subtract 1 from hit rolls for attacks that target this unit in the Shooting phase.

FACTION KEYWORDS

TYRANIDS, GENESTEALER CULTS, <CULT>

KEYWORDS

BIKER, ATALAN JACKALS

ATALAN WEAPONS LIST

WEAPONS	RANGE	TYPE	S	AP	D	ABILITIES
Autogun	24"	Rapid Fire 1	3	0	1	-
Bolt pistol	12"	Pistol 1	4	0	1	-
Cultist knife	Melee	Melee	User	0	1	Each time the bearer fights, it can make 1 additional attack with this weapon.
Demolition charge	6"	Grenade D6	8	-3	D3	The bearer can only use this weapon once per battle.
Grenade launcher	When attacking with this weapon, choose one of the profiles below.					
- Frag grenade	24"	Assault D6	3	0	1	-
- Krak grenade	24"	Assault 1	6	-1	D3	-
Power axe	Melee	Melee	+1	-2	1	-
Power hammer	Melee	Melee	+2	-1	1	-

ATALAN JACKALS



NOM	M	CC	GT	F	E	PV	A	Gd	Sv
Atalan Jackal	14"	4+	4+	3	4	2	1	7	5+
Atalan Leader	14"	4+	4+	3	4	2	2	8	5+
Atalan Wolfquad	14"	4+	4+	3	4	4	1	7	5+

Cette unité contient 1 Atalan Leader et 3 Atalan Jackals. Elle peut inclure 4 Atalan Jackals additionnels (**Rang de Puissance +3**) ou 8 Atalan Jackals additionnels (**Rang de Puissance +6**). Par tranche de 4 Atalan Jackals et/ou Atalan Leaders dans l'unité, elle peut inclure 1 Atalan Wolfquad (**Rang de Puissance +2 par figurine**). Chaque figurine est armée d'un pistolet-mitrailleur et de charges explosives. Chaque Atalan Wolfquad est en outre équipé d'une mitrailleuse.

ARME	PORTÉE	TYPE	F	PA	D	APTITUDES
Incinérateur Atalan	12"	Lourde D6	5	-1	1	Cette arme touche automatiquement sa cible.
Pistolet-mitrailleur	12"	Pistolet 1	3	0	1	-
Mitrailleuse	36"	Lourde 3	4	0	1	-
Laser minier	24"	Lourde 1	9	-3	D6	-
Fusil à pompe	12"	Assaut 2	3	0	1	Si la figurine est à demi-portée ou moins, ajoutez 1 à la Force de cette arme.
Arme improvisée	Mêlée	Mêlée	Util.	0	1	-
Pioche énergétique	Mêlée	Mêlée	Util.	-2	D3	Chaque fois qu'une figurine avec serre perforante effectue une attaque avec cette arme, elle peut effectuer une attaque supplémentaire avec sa serre perforante.
Charge explosive	6"	Grenade D6	3	0	1	-

OPTIONS D'ÉQUIPEMENT

- L'Atalan Leader et chaque Atalan Jackal doivent recevoir deux armes de la liste *Armes d'Atalan*. Une même figurine ne peut pas recevoir deux fois la même arme. Une de ces figurines sur quatre peut recevoir un lance-grenades, et seul l'Atalan Leader peut recevoir un fusil d'assaut, un pistolet bolter ou une hache énergétique.
- Chaque Atalan Wolfquad peut recevoir une des armes suivantes : pistolet-mitrailleur, fusil à pompe, arme improvisée ou pioche énergétique.
- Chaque Atalan Wolfquad peut remplacer sa mitrailleuse par un laser minier ou un Incinérateur Atalan.

APTITUDES

Embuscade du Culte, Loyauté Aveugle

Éclaireur Compétent : Soustrayez 1 aux jets de touche des attaques qui ciblent cette unité à la phase de Tir.

MOTS-CLÉS DE FACTION

TYRANIDS, GENESTEALER CULTS, <CULTE>

MOTS-CLÉS

MOTARD, ATALAN JACKALS

LISTE D'ARMES D'ATALANS

ARMES	PORTÉE	TYPE	F	PA	D	APTITUDES
Pistolet-mitrailleur	24"	Tir Rapide 1	3	0	1	-
Pistolet bolter	12"	Pistolet 1	4	0	1	-
Poignard de cultiste	Mêlée	Mêlée	Util.	0	1	Chaque fois que le porteur combat, il peut effectuer 1 attaque supplémentaire avec cette arme.
Charge de démolition	6"	Grenade D6	8	-3	D3	Le porteur ne peut utiliser cette arme qu'une fois par bataille.
Lance-grenades	Lorsque vous attaquez avec cette arme, choisissez 1 des profils ci-dessous.					
- Grenade Frag	24"	Assaut D6	3	0	1	-
- Grenade Krak	24"	Assaut 1	6	-1	D3	-
Hache énergétique	Mêlée	Mêlée	+1	-2	1	-
Marteau énergétique	Mêlée	Mêlée	+2	-1	1	-

ATALAN JACKALS



NOMBRE	M	HA	HP	F	R	H	A	L	S
Atalan Jackal	14"	4+	4+	3	4	2	1	7	5+
Atalan Leader	14"	4+	4+	3	4	2	2	8	5+
Atalan Wolfquad	14"	4+	4+	3	4	4	1	7	5+

Esta unidad consta de 1 Atalan Leader y 3 Atalan Jackals. Puede incluir 4 Atalan Jackals adicionales (**Potencia de unidad +3**) u 8 Atalan Jackals adicionales (**Potencia de unidad +6**). Por cada cuatro Atalan Jackals y/o Atalan Leaders en la unidad, ésta puede incluir 1 Atalan Wolfquad (**Potencia de unidad +2 por miniatura**). Cada miniatura va armada con una pistola automática y cargas explosivas. Cada Atalan Wolfquad también está equipado con una ametralladora pesada.

ARMAS	ALC.	TIPO	F	FP	D	HABILIDADES
Incinerador Atalan	12"	Pesada 1D6	5	-1	1	Esta arma impacta en el blanco automáticamente.
Pistola automática	12"	Pistola 1	3	0	1	-
Ametralladora pesada	36"	Pesada 3	4	0	1	-
Láser de minería	24"	Pesada 1	9	-3	1D6	-
Escopeta	12"	Asalto 2	3	0	1	Si el blanco está a la mitad del alcance, o más cerca, suma 1 a la Fuerza de esta arma.
Arma improvisada	Com.	Combate	Port.	0	1	-
Pico de energía	Com.	Combate	Port.	-2	1D3	Cada vez que una miniatura con garra acerada haga un ataque con esta arma, puede hacer un ataque adicional con la garra acerada.
Carga explosiva	6"	Granada 1D6	3	0	1	-

OPCIONES DE EQUIPO

- El Atalan Leader y cada Atalan Jackal debe elegir dos armas de la lista de *Armas atalanas*. La misma miniatura no puede elegir dos veces la misma arma. Sólo una de cada cuatro de estas miniaturas puede elegir un lanzagranadas y sólo el Atalan Leader puede elegir un rifle automático, pistola bólter o hacha de energía.
- Cualquier Atalan Wolfquad puede elegir una de las siguientes: pistola automática, escopeta, arma improvisada o pico de energía.
- Cualquier Atalan Wolfquad puede cambiar la ametralladora pesada por un láser de minería o un incinerador Atalan.

HABILIDADES

Emboscada del culto, Lealtad incondicional

Escoltas hábiles. Resta 1 a las tiradas para impactar de ataques que tengan como blanco a esta unidad en la fase de disparo.

CLAVES DE FACCIÓN

TYRANIDS, GENESTEALER CULTS, <CULTO>

CLAVES

MOTORISTA, ATALAN JACKALS

LISTA DE ARMAS ATALANAS

ARMAS	ALCANCE	TIPO	F	FP	D	HABILIDADES
Carga de demolición	6"	Granada 1D6	8	-3	1D3	El portador sólo puede usar esta arma una vez por batalla.
Cuchillo de Cultist	Com.	Combate	Port.	0	1	Cada vez que el portador lucha puede hacer 1 ataque adicional con esta arma.
Hacha de energía	Com.	Combate	+1	-2	1	-
Lanzagranadas	Al atacar con esta arma, elige uno de los siguientes perfiles					
- Granada frag	24"	Asalto 1D6	3	0	1	-
- Granada perforante	24"	Asalto 1	6	-1	1D3	-
Martillo de energía	Com.	Combate	+2	-1	1	-
Pistola bólter	12"	Pistola 1	4	0	1	-
Rifle automático	24"	Fuego rápido 1	3	0	1	-

ATALAN JACKALS



NAME	B	KG	BF	S	W	LP	A	MW	RW
Atalan Jackal	14"	4+	4+	3	4	2	1	7	5+
Atalan Leader	14"	4+	4+	3	4	2	2	8	5+
Atalan Wolfquad	14"	4+	4+	3	4	4	1	7	5+

Diese Einheit besteht aus 1 Atalan Leader und 3 Atalan Jackals. Sie darf bis zu vier zusätzliche Atalan Jackals (**Macht +3**) oder bis zu 8 zusätzliche Atalan Jackals enthalten (**Macht +6**). Für jeweils vier Atalan Jackals und/oder Atalan Leaders in der Einheit darf sie 1 Atalan Wolfquad enthalten (**Macht +2 pro Modell**). Jedes Modell ist mit einer Maschinenpistole und Bergbausprengladungen bewaffnet. Jedes Atalan Wolfquad ist außerdem mit einem Maschinengewehr bewaffnet.

WAFFE	REICHW.	TYP	S	DS	SW	FÄHIGKEITEN
Atalan-Brenner	12"	Schwer W6	5	-1	1	Diese Waffe trifft ihr Ziel automatisch.
Bergbaulaser	24"	Schwer 1	9	-3	W6	-
Maschinengewehr	36"	Schwer 3	4	0	1	-
Maschinenpistole	12"	Pistole 1	3	0	1	-
Schrotflinte	12"	Sturm 2	3	0	1	Wenn sich das Ziel innerhalb der halben Reichweite befindet, addiere 1 auf den Stärkewert dieser Waffe.
Bergbauhacke	Nahkampf	Nahkampf	Träger	-2	W3	Jedes Mal, wenn ein Modell mit Zangenkralle eine Attacke mit dieser Waffe ausführt, darf es auch eine zusätzliche Attacke mit seiner Zangenkralle ausführen.
Improvisierte Waffe	Nahkampf	Nahkampf	Träger	0	1	-
Bergbausprengladungen	6"	Granate W6	3	0	1	-

AUSRÜSTUNGSOPTIONEN

- Der Atalan Leader und jeder Atalan Jackal müssen jeweils zwei Waffen von der Liste der Atalan-Waffen wählen. Kein Modell darf zweimal die gleiche Waffe wählen. Nur ein Modell von vier darf einen Granatwerfer wählen. Nur der Atalan Leader darf ein Sturmgewehr, eine Bolt pistole oder eine Bergbauhacke wählen.
- Jedes Atalan Wolfquad darf eine dieser Waffen erhalten: Maschinenpistole, Schrotflinte, Improvisierte Waffe oder Bergbauhacke.
- Jedes Atalan Wolfquad darf sein Maschinengewehr entweder durch einen Bergbaulaser oder einen Atalan-Brenner ersetzen.

FÄHIGKEITEN

Cult-Hinterhalt, Bedingungslose Loyalität

Geschickt im Sattel: Ziehe 1 von Trefferwürfen für Attacken während der Fernkampfphase ab, die diese Einheit zum Ziel haben.

FRAKTION

TYRANIDS, GENESTEALER CULTS, <CULT>

SCHLÜSSELWÖRTER

BIKER, ATALAN JACKALS

ATALAN-WAFFENLISTE

WAFFE	REICHW.	TYP	S	DS	SW	FÄHIGKEITEN
Boltpistole	12"	Pistole 1	4	0	1	-
Granatwerfer	Wähle eines der folgenden Profile, wenn du mit dieser Waffe attackierst.					
- Fragmentgranate	24"	Sturm W6	3	0	1	-
- Sprenggranate	24"	Sturm 1	6	-1	W3	-
Sturmgewehr	24"	Schnellfeuer 1	3	0	1	-
Bergbauhammer	Nahkampf	Nahkampf	+2	-1	1	-
Cultist-Messer	Nahkampf	Nahkampf	Träger	0	1	Jedes Mal, wenn der Träger kämpft, darf er 1 zusätzliche Attacke mit dieser Waffe ausführen.
Energieaxt	Nahkampf	Nahkampf	+1	-2	1	-
Sprengladung	6"	Granate W6	8	-3	W3	Der Träger darf diese Waffe nur einmal pro Schlacht einsetzen.

ATALAN JACKALS



NOME	M	AC	AB	Fo	R	Fe	A	D	S
Atalan Jackal	14"	4+	4+	3	4	2	1	7	5+
Atalan Leader	14"	4+	4+	3	4	2	2	8	5+
Atalan Wolfquad	14"	4+	4+	3	4	4	1	7	5+

Questa unità include 1 Atalan Leader e 3 Atalan Jackals. Può comprendere 4 Atalan Jackals addizionali (**Valore di Potenza +3**) o 8 Atalan Jackals addizionali (**Valore di Potenza +6**). Ogni quattro Atalan Jackals e/o Atalan Leaders dell'unità, può includere 1 Atalan Wolfquad (**Valore di Potenza +2 per modello**). Ciascun modello è armato con pistola automatica e cariche esplosive. Ciascun Atalan Wolfquad è anche equipaggiato con mitragliatore pesante.

ARMI	GITTATA	TIPO	Fo	VP	Da	ABILITÀ
Inceneritore Atalan	12"	Pesante D6	5	-1	1	Quest'arma colpisce automaticamente il bersaglio.
Pistola automatica	12"	Pistola 1	3	0	1	-
Mitragliatore pesante	36"	Pesante 3	4	0	1	-
Laser minatore	24"	Pesante 1	9	-3	D6	-
Fucile a pompa	12"	Assalto 2	3	0	1	Se il bersaglio si trova entro metà gittata, aggiungi 1 alla Forza di quest'arma.
Arma improvvisata	Mischia	Mischia	Mod.	0	1	-
Piccone potenziato	Mischia	Mischia	Mod.	-2	D3	Ogni volta che un modello con artiglio dilaniante effettua un attacco con quest'arma, può effettuare un attacco addizionale con il suo artiglio dilaniante.
Carica esplosiva	6"	Granata D6	3	0	1	-

OPZIONI DI EQUIPAGGIAMENTO

- L'Atalan Leader e ogni Atalan Jackal devono prendere due armi dalla lista *Armi degli Atalan*. Lo stesso modello non può prendere la stessa arma due volte. Solo uno ogni quattro di questi modelli può prendere un lanciagranate, e solo l'Atalan Leader può prendere un fucile automatico, una pistola requiem o un'ascia potenziata.
- Qualsiasi Atalan Wolfquad può prendere una delle seguenti: pistola automatica, fucile a pompa, arma improvvisata o piccone potenziato.
- Qualsiasi Atalan Wolfquad può sostituire il mitragliatore pesante con un laser minatore o un inceneritore Atalan.

ABILITÀ

Imboscata del Culto, Lealtà Incondizionata

Staffette Esperte: nella fase di Tiro sottrai 1 dai tiri per colpire degli attacchi che hanno come bersaglio questa unità.

KEYWORDS DI FAZIONE

TYRANIDS, GENESTEALER CULTS, <CULTO>

KEYWORDS

MOTOCICLISTA, ATALAN JACKALS

ARMI DEGLI ATALAN

ARMI	GITTATA	TIPO	Fd	VP	DA	ABILITÀ
Fucile automatico	24"	Cadenza Rapida 1	3	0	1	-
Pistola requiem	12"	Pistola 1	4	0	1	-
Coltello dei cultisti	Mischia	Mischia	Mod.	0	1	Ogni volta che il portatore combatte, può effettuare 1 attacco addizionale con quest'arma.
Carica da demolizione	6"	Granata D6	8	-3	D3	Il portatore può usare quest'arma solo una volta per battaglia.
Lanciagranate	Quando attacchi con quest'arma, scegli uno dei profili in basso.					
- Granata a frammentazione	24"	Assalto D6	3	0	1	-
- Granata perforante	24"	Assalto 1	6	-1	D3	-
Ascia potenziata	Mischia	Mischia	+1	-2	1	-
Martello potenziato	Mischia	Mischia	+2	-1	1	-