



Free Downloads of Build Instructions,
Assembly Booklets & How To Guides

BuildInstructions.com

WARHAMMER AGE OF SIGMAR

FREEGUILD FUSILIERS

FUSILIERS DES GUILDES FRANCHES • FUSILEROS DEL GREMIO LIBRE • FREIGILDEN FÜSILIERE
FUCILIERI DELLA GILDA LIBERA • フリーギルド・フェュシリア • 自由兵团燧发枪士兵

READ THIS FIRST • À LIRE EN PRIORITÉ • BITTE BEACHTEN • LEE ESTO PRIMERO
LEGGI PRIMA QUESTO • 最初にお読みください • 请优先阅读

ENG BEFORE ASSEMBLING YOUR MINIATURES, PLEASE READ THROUGH THE INSTRUCTIONS IN THIS BOOKLET CAREFULLY. A pair of plastic cutters is required to remove the plastic components in this kit from their frame. We advise using a mouldline scraping tool to clean up the parts. To assemble your model you will need plastic glue. Games Workshop sells Citadel Fine Detail Cutters, Citadel Mouldline Remover and Citadel Plastic Glue, but does not recommend these products for use by children under the age of 16 without adult supervision.

FRE AVANT D'ASSEMBLER VOS FIGURINES, VEUILLEZ LIRE ATTENTIVEMENT LES INSTRUCTIONS DE CE LIVRET. Une pince coupante est requise pour détacher chaque élément de sa grappe. Nous vous recommandons l'utilisation d'un grattoir pour ébarber les éléments. Pour l'assemblage, vous aurez également besoin de colle plastique. Games Workshop commercialise les Pinces de Précision Citadel, l'Ébarboir Citadel et la Colle Plastique Citadel, mais n'en recommande pas l'utilisation pour des enfants de moins de 16 ans sans la supervision d'un adulte.

SPA POR FAVOR, LEE CUIDADOSAMENTE ESTE LIBRETO DE INSTRUCCIONES ANTES DE EMPEZAR A MONTAR LAS MINIATURAS. Te harán falta unas tenazas para plástico a fin de separar las piezas de la matriz. También aconsejamos una herramienta para rebabas a fin de limpiar cada pieza. Para montar la miniatura necesitarás pegamento para plástico. Games Workshop vende Tenazas Citadel, Herramientas para rebabas Citadel y Pegamento para plástico Citadel, pero no recomienda estos productos a menores de 16 años sin la supervisión de un adulto.

GER VOR DEM ZUSAMMENBAU DER MINIATUREN BITTE DIE ANWEISUNGEN IN DIESER ANLEITUNG AUFMERKSAM DURCHLESEN. Du benötigst einen Kunststoffseitenschneider, um die Kunststoffbauteile aus dem Gussrahmen herauszutrennen, und Kunststoffkleber, um die Miniatur zusammenzubauen. Außerdem empfehlen wir, die Bauteile vorher mit einem Gussgratentferner zu säubern. Games Workshop bietet Präzisions-Kunststoffseitenschneider von Citadel sowie Citadel-Kunststoffkleber an, empfiehlt aber, dass Kinder unter 16 Jahren diese nur unter Aufsicht eines Erwachsenen benutzen.

ITA PRIMA DI ASSEMBLARE LE TUE MINIATURE LEGGI ATTENTAMENTE TUTTE LE ISTRUZIONI DI QUESTO LIBRETTO. Sono necessarie un paio di tronchesine per plastica per staccare i componenti dai loro sprue. Consigliamo di usare un attrezzo apposito per pulire i componenti. Per assemblare il modello avrai bisogno di colla per plastica. Games Workshop vende Tronchesine di precisione Citadel, Attrezzo per ripulire Citadel e Colla per plastica Citadel, ma non consiglia questi prodotti ad un pubblico minore di 16 anni senza la supervisione di un adulto.

日本 本キット内のフレームからプラスチックパーツを切り離すためには、ニッパーが必要です。パーツのモールドを平らにするには、専用ツールの使用をお勧めいたします。本キットの組み立てには、プラ用接着剤が必要です。ゲームズワークショップはシタデル・ニッパー、プラ用接着剤、シタデル・モールドラインリムーバーを販売しておりますが、16歳以下の子供が大人の監督なしにこれらの道具を使用されることをお勧めしません。

中文 你需要一把模型剪将塑料部件从板件上剪下来。我们建议使用分模线刮刀来处理零件。组装时你还需要用到模型胶水。你可以从 Games Workshop 处购买到 Citadel Fine Detail Cutter 模型剪、Citadel Mouldline Remover 分模线刮刀和 Citadel Plastic Glue 模型胶，但 16 岁以下儿童不得在没有成年人监护的情况下使用这些产品。

EXPLANATION OF SYMBOLS • EXPLICATION DES SYMBOLES • EXPLICACIÓN DE SÍMBOLOS
ERLÄUTERUNG DER SYMBOLE • LEGENDA DEI SIMBOLI • アイコン解説 • 符号说明



- Choice of parts
- Choix d'éléments
- Modelos de componentes
- Auswahl an Teilen
- Scelta di componenti
- パーツの選択
- 选择部件



- Variant assembly
- Variante d'assemblage
- Variante de montaje
- Bauvariante
- Assemblaggio alternativo
- 組み立てバリエーション
- 多种组装方式



- Dry fit stage before gluing
- Tester avant de coller
- Comprobar el encaje antes de pegar
- Positionierung erst ohne Klebstoff ausprobieren
- Prova a secco prima di incollare
- 接着前にぴったり合わせる
- 粘接前的假组阶段



- Build the number required, up to the limit shown
- Assembler le nombre requis jusqu'à la limite indiquée



- Stage complete
- Étape terminée

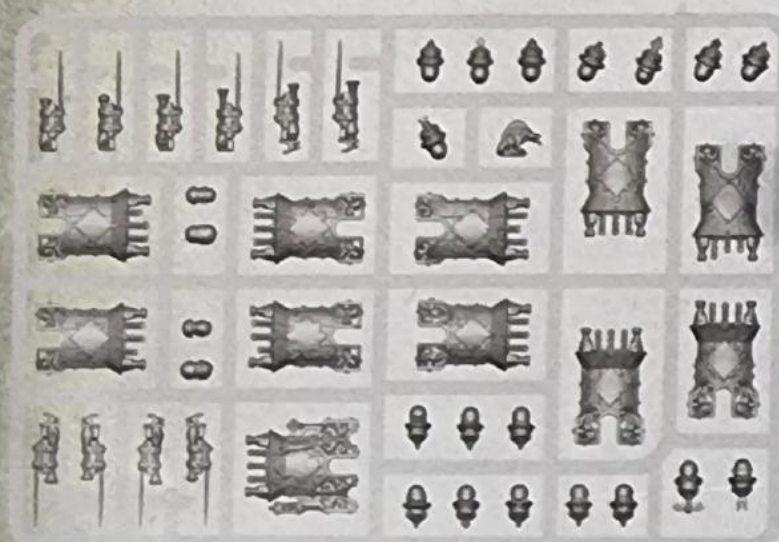

**BUILD VARIANTS • VARIANTES D'ASSEMBLAGE • VARIANTES DE MONTAJE • BAUVARIANTEN
VARIANTI D'ASSEMBLAGGIO • パリエーション • 変体版**

- Assemblies for build variants are colour coded.
- Les assemblages de variantes ont un code couleur.
- Las instrucciones para montajes alternativos se indican con un color diferente.
- Optionen für Bauvarianten sind farblich markiert.
- Le diverse varianti d'assemblaggio sono divise per colore.
- パリエーションごとの組み立ては色分けされています。
- 変体版の装飾部は有彩色区分。





• Special instruction - Take care • Instruction spéciale - Faites attention • Instrucciones especiales - Presta atención
 • Besondere Anweisung - bitte beachten • Istruzioni speciali: prestare attenzione • 特記事項 - 要注意 • 特别说明 - 小心



1:1

**CITADEL
COLOUR**





1

- Interchangeable parts • Éléments interchangeables • Partes intercambiables • Austauschbare Teile
- Componenti intercambiabili • 組み換え可能な部品 • 可互换零件

1 a



1 b



1 c

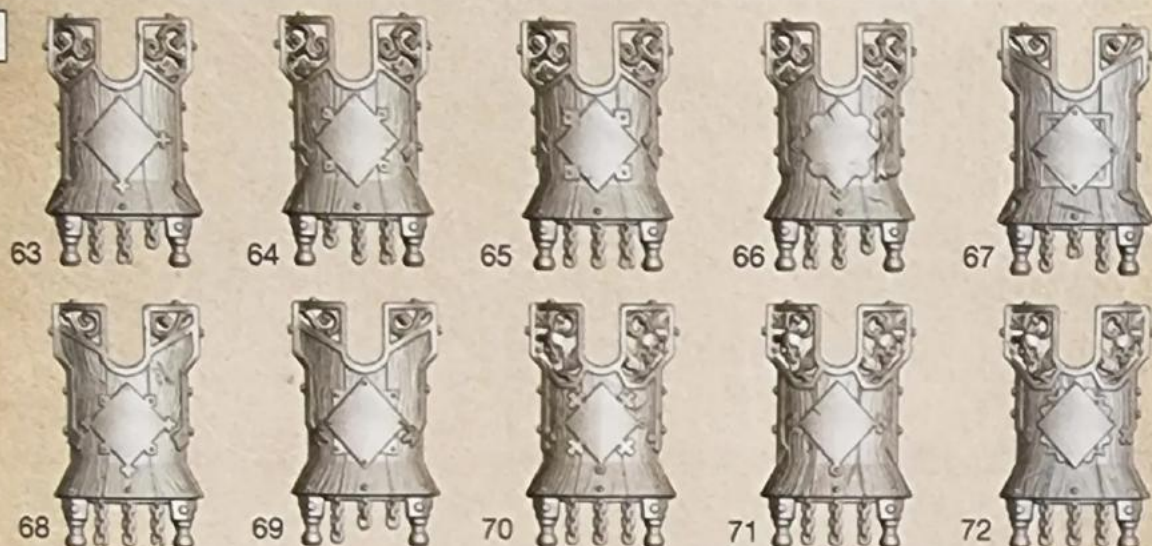

! 2

- Choose the variant you want to build
- Choisissez la variante à assembler
- Elige qué versión quieres montar
- Wähle die Variante, die du bauen möchtest

- Scegli la variante che vuoi assemblare
- 組み立てバリエーションの選択
- 选择你喜欢的拼装方式

2a-2c

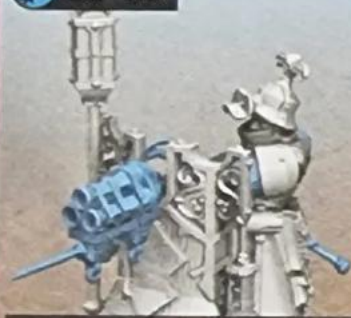

• Champion • Campçon • Campione • チャンピオン • 勇士

2a; 2d - 2e



2a; 2f - 2g

- Freeguild Fusiliers
- Fusiliers des Guildes Franches
- Fusileros del Gremio Libre
- Freigilden-Füsilier
- Fucilieri della Gilda Libera
- フリーギルド・フュージリア
- 自由兵団燧发枪士兵



2 a

27



2 b

28



32

2 a

34

33



2 c



2 d

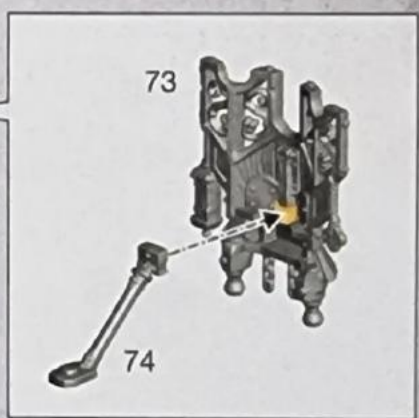

2 e

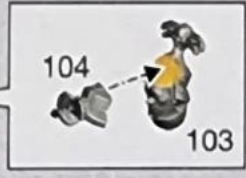
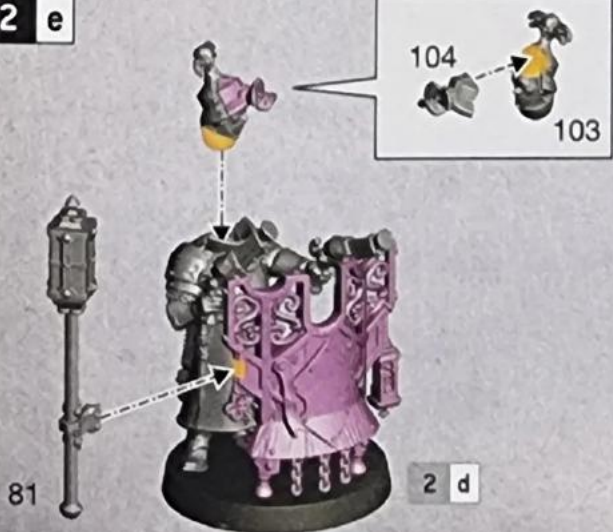

2 f

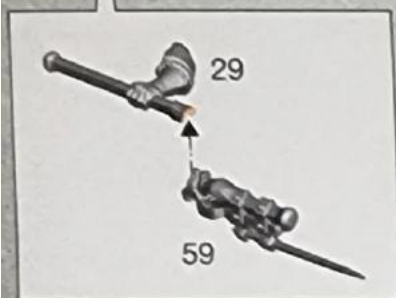

2 g



3 a

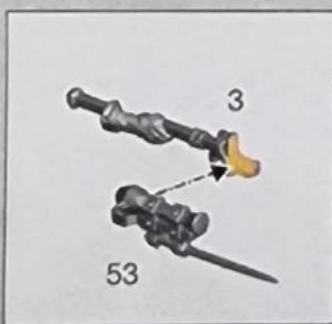

▶▶ 3 b



▶▶ 4 a

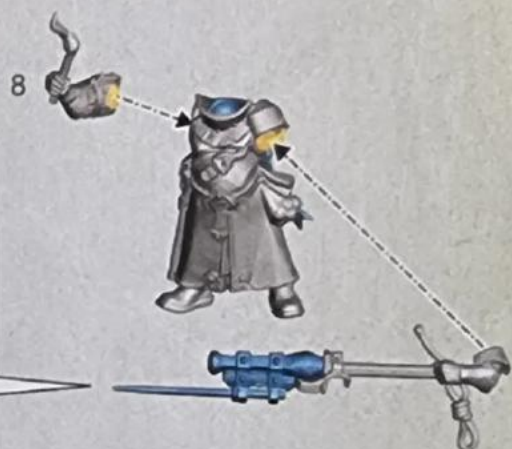

▶▶ 4 b



5 a



5 b



6 a

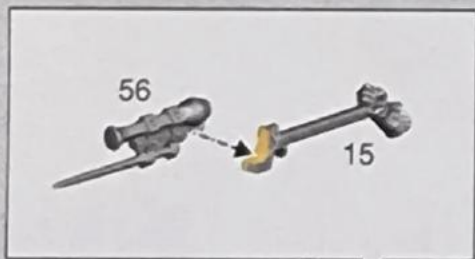

6 b



7 a

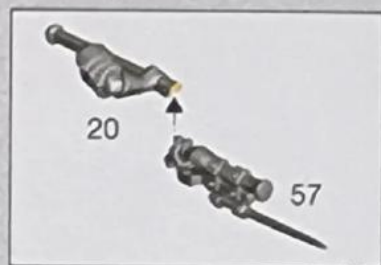

7 b

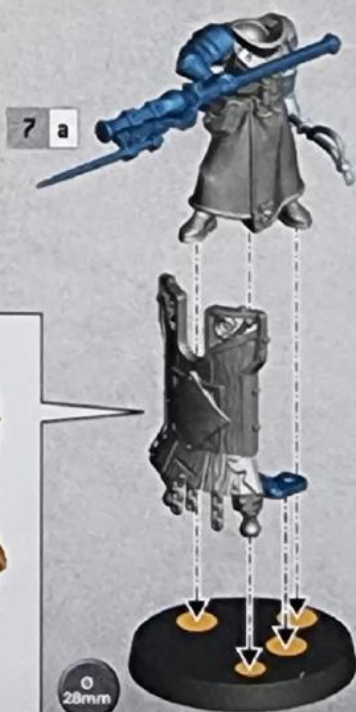

8 a



8 b



9 a

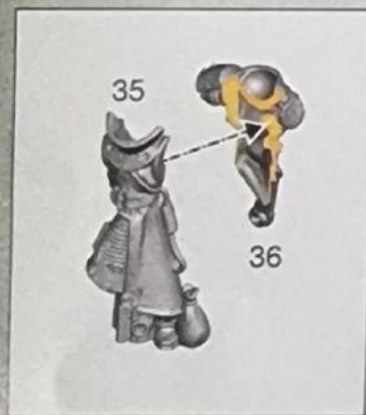

▶ 9 b



▶ 10 a

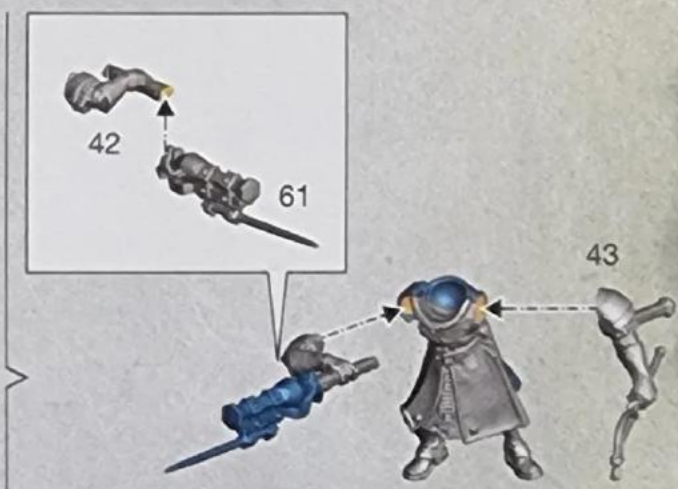
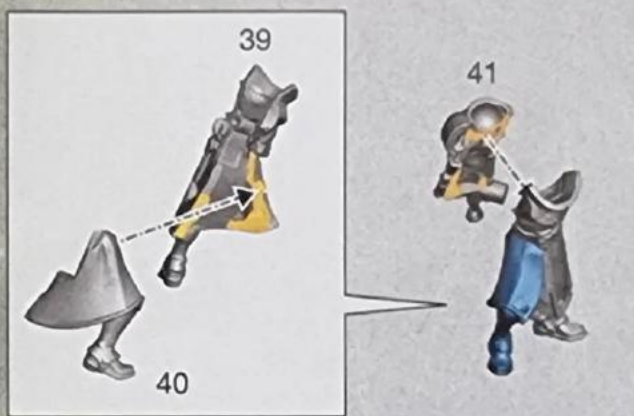

▶ 10 b

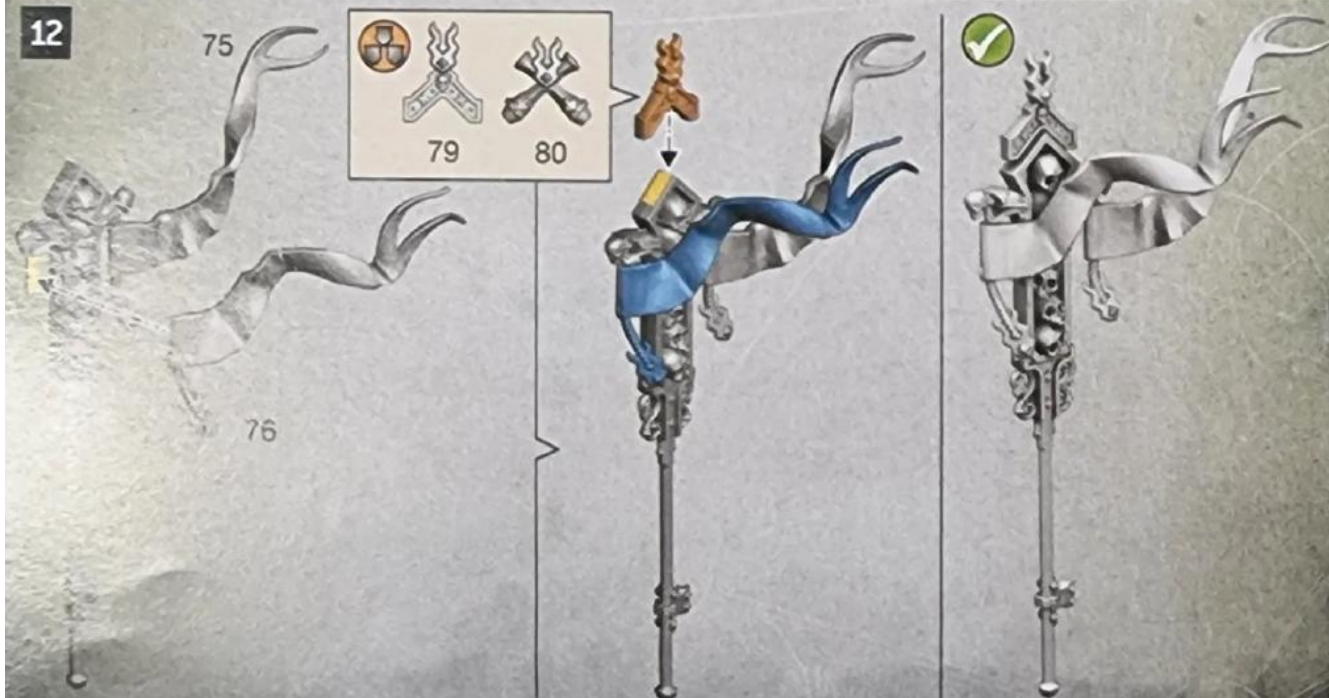

11 a**11 b****12**



12

≤1

- Standard Bearer
- Porte-étendard
- Portaestandartes
- Standartenträger
- Alfiere
- スタンダードベアラ
- 旗手



77



78



105



106



3-12



14

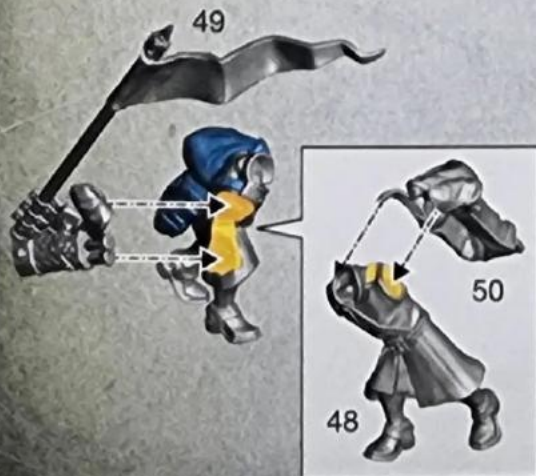

49

50

48



51

52

25mm







ENG More painting guides can be found on citadelcolour.com
FRE D'autres guides de peinture sont disponibles citadelcolour.com
SPA Encontrarás más guías de pintura en citadelcolour.com
GER Weitere Bemalanleitungen auf citadelcolour.com

ITA Puoi trovare altre guide alla pittura su citadelcolour.com
日本語 citadelcolour.com には他にも様々なペイントガイドが掲載されている
中文 更多涂装指南请至 citadelcolour.com.



ENG Used alongside the core rules found on warhammer.com, the following essential rules will get your new unit on the battlefield. For the full rules for this unit, see the battletome relevant to your army.

FRE Utilisées avec les règles de base disponibles sur warhammer.com, les règles essentielles qui suivent vous permettront de jouer votre nouvelle unité. Pour connaître les règles complètes de cette unité, consultez le Tome de Bataille correspondant à votre armée.

SPA Usadas junto con las reglas básicas que encontrarás en warhammer.com, las siguientes reglas esenciales te permiten desplegar esta nueva unidad en el campo de batalla. Para ver las reglas completas de esta unidad, consulta el Tomo de batalla correspondiente a tu ejército.

GER Mit den Grundregeln auf warhammer.com und den folgenden grundlegenden Regeln kannst du deine neue Einheit direkt auf das Schlachtfeld führen. Die vollständigen Regeln für diese Einheit findest du im Kriegsbuch deiner Armee.

ITA Con le seguenti regole fondamentali, usate assieme alle regole base che puoi trovare su warhammer.com, potrai schierare in campo la tua nuova unità. Per le regole complete di questa unità vedi il tomo da guerra della tua armata.

日本語 warhammer.comに掲載されているコアルールと一緒に使用することで、以下の簡易版ルールでこのユニットを戦場で使用することができます。このユニットの完全版ルールについては、アーマーに対応したバトルトームを参照してください。

中文 与 warhammer.com 上的核心规则一起使用，以下基本规则适用于您在战场上的新单位。有关该单位的完整规则，请参阅与您的军队相关的战斗宝典。

FREEGUILD FUSILIERS

FUSILIERS DES GUILDES FRANCHES • FUSILEROS DEL GREMIO LIBRE
FREIGILDEN-FÜSILIERE • FUCILIERI DELLA GILDA LIBERA
フリーギルド・フェュージリア • 自由兵团燧发枪士兵



Icon	Value	Icon	Value	Icon	Value	Icon	Value
☀	24"	☠	2	✂	4+	☠	4+
🛡	12"	☠	1	✂	4+	☠	4+
🔥	9"	☠	4	✂	3+	☠	3+
☠	1"	☠	1	✂	4+	☠	4+

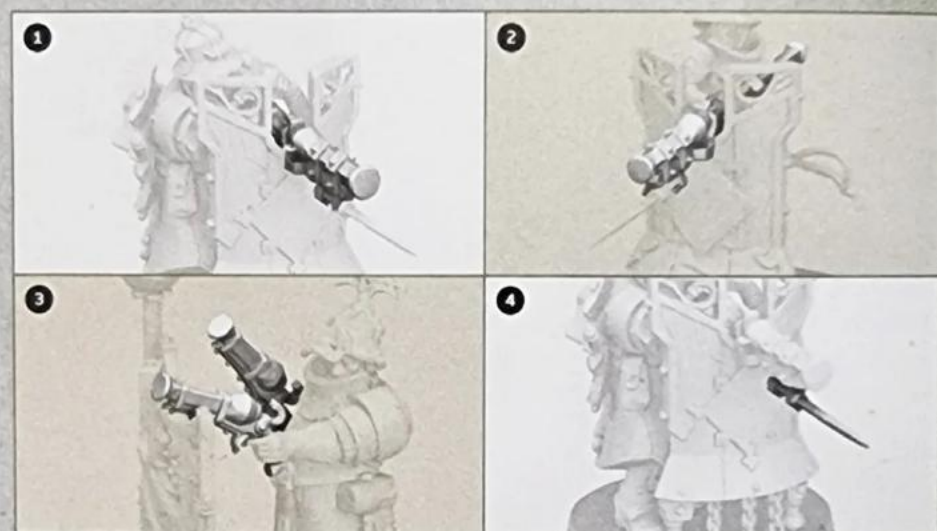

ICON KEY • LÉGENDE DES ICÔNES • CLAVE DE ICONOS • BEDEUTUNG DER SYMBOLE • LEGENDA DELLE ICONE • アイコン説明・図例

	☀	🛡	🔥	☠	☠	☠	☠	☠	☠	☠	☠	☠	☠
ENG	Move	Save	Wounds	Bravery	Missile Weapon	Melee Weapon	Range	Attacks	To Hit	To Wound	Rend	Damage	
FRE	Mouvement	Sauvegarde	Blessures	Bravoure	Armes à Projectiles	Armes de Mêlée	Portée	Attaques	Toucher	Blesser	Perf.	Dégâts	
SPA	Mov.	Salvación	Heridas	Coraje	Armas a distancia	Armas de combate	Alcance	Ataques	Impactar	Herir	Perforar	Daño	
GER	Bewegung	Schutz	Wunden	Mut	Fernkampfwaffen	Nahkampfwaffen	Reichw.	Attacken	Treffen	Verwunden	Wucht	Schaden	
ITA	Mov.	Salvezza	Ferite	Coraggio	Armi da tiro	Armi da mischia	Gittata	Attacchi	Per Colpire	Per Ferire	Impatto	Danni	
日本語	移動力	防御力	負傷 限界値	勇猛度	射撃武器	接近戦武器	射程	攻撃回数	ヒット 成功値	ウーンズ 成功値	貫通値	ダメージ量	
中文	移动	防御	伤害 限值	勇气	远程武器	近战武器	射程	攻击	命中	致伤	穿甲	伤害	



WARHAMMER.COM

Games Workshop Limited, Willow Road,
Nottingham, NG7 2WS, UK

© Copyright Games Workshop Limited 2023.

