



Free Downloads of Build Instructions,  
Assembly Booklets & How To Guides

**BuildInstructions.com**

# WARHAMMER 40,000

## FIELD ORDNANCE BATTERY

BATTERIE D'ARTILLERIE | BATERÍA DE ARTILLERÍA DE CAMPAÑA | FELDGESCHÜTZBATTERIE | BATTERIA D'ARTIGLIERIA MOBILE

БАТАРЕЯ ПОЛЕВОЙ АРТИЛЛЕРИИ | フィールド・オードナンス・バッテリー | 野战炮群



**!** READ THIS FIRST | À LIRE EN PRIORITÉ | BITTE BEACHTE | LEE ESTO PRIMERO | LEGGI PRIMA QUESTO  
В ПЕРВУЮ ОЧЕРЕДЬ ПРОЧИТАЙТЕ ЭТО | 最初にお読みください。 | 请优先阅读

**ENG** BEFORE ASSEMBLING YOUR MINIATURES, PLEASE READ THROUGH THE INSTRUCTIONS IN THIS BOOKLET CAREFULLY. A pair of plastic cutters is required to remove the plastic components in this kit from their frame. We advise using a mouldline scraping tool to clean up the parts. To assemble your model you will need plastic glue. Games Workshop sells Citadel Fine Detail Cutters, Citadel Mouldline Remover and Citadel Plastic Glue, but does not recommend these products for use by children under the age of 16 without adult supervision.

**FRE** AVANT D'ASSEMBLER VOS FIGURINES, VEUILLEZ LIRE ATTENTIVEMENT LES INSTRUCTIONS DE CE LIVRET. Une pince coupante est requise pour détacher chaque élément de sa grappe. Nous vous recommandons l'utilisation d'un grattoir pour ébarber les éléments. Pour l'assemblage, vous aurez également besoin de colle plastique. Games Workshop commercialise les Pinces de Précision Citadel, l'Ébarboir Citadel et la Colle Plastique Citadel, mais n'en recommande pas l'utilisation pour des enfants de moins de 16 ans sans la supervision d'un adulte.

**SPA** POR FAVOR, LEE CUIDADOSAMENTE ESTE LIBRETO DE INSTRUCCIONES ANTES DE EMPEZAR A MONTAR LAS MINIATURAS. Te harán falta unas tenazas para plástico a fin de separar las piezas de la matriz. También aconsejamos una herramienta para rebabas a fin de limpiar cada pieza. Para montar la miniatura necesitarás pegamento para plástico. Games Workshop vende Tenazas Citadel, Herramientas para rebabas Citadel y Pegamento para plástico Citadel, pero no recomienda estos productos a menores de 16 años sin la supervisión de un adulto.









**GER** VOR DEM ZUSAMMENBAU DER MINIATUREN BITTE DIE ANWEISUNGEN IN DIESER ANLEITUNG AUFMERKSAM DURCHLESEN. Du benötigst einen Kunststoffseitenschneider, um die Kunststoffbauteile aus dem Gussrahmen herauszutrennen, und

**ITA** PRIMA DI ASSEMBLARE LE TUE MINIATURE LEGGI ATTENTAMENTE TUTTE LE ISTRUZIONI DI QUESTO LIBRETTO. Sono necessarie un paio di tronchesine per plastica per staccare i componenti dai loro sprue. Consigliamo di usare un attrezzo apposito per pulire i componenti. Per assemblare il modello avrai bisogno di colla per plastica. Games Workshop vende Tronchesine di precisione Citadel, Attrezzo per ripulire Citadel e Colla per plastica Citadel, ma non consiglia questi prodotti ad un pubblico minore di 16 anni senza la supervisione di un adulto.

**RUS** Кусачки для пластика нужны для снятия пластиковых элементов набора с рамок. Для зачистки деталей рекомендуем использовать инструмент для удаления дефектов. Для сборки модели вам понадобится клей для пластика. Компания Games Workshop предоставляет кусачки «Citadel Fine Detail Cutters», инструмент для удаления дефектов «Citadel Mouldline Remover» и клей для пластика «Citadel Plastic Glue», но не рекомендует эти изделия для использованию детьми младше 16 лет без надзора взрослых.

**日本語** 本キット内のフレームからプラスチックパーツを切り離すためには、ニッパーが必要です。パーツのモールドを平らにするには、専用ツールの使用をお勧めいたします。本キットの組み立てには、プラ用接着剤が必要です。ゲームワークショップはシタデル・ニッパー、プラ用接着剤、シタデル・モールドラインリムーバーを販売しておりますが、16歳以下の子供が大人の監督なしにこれらの道具を使用されることをお勧めしません。

**中文** 你需要一把模型剪将塑料部件从板件上剪下来。我们建议使用分模线刮刀来处理零件。组装时你还需要用到模型胶水。你可以从...

- |  |   |  |
|--|---|--|
| <p> • Special instruction - take care<br/>         • Instruction spéciale - faites attention<br/>         • Instrucciones especiales - presta atención<br/>         • Besondere Anweisung - bitte beachten<br/>         • Istruzioni speciali: prestare attenzione<br/>         • Особая инструкция - Будьте осторожны<br/>         • 特記事項 - 要注意<br/>         • 特别说明 - 小心</p>  | <p> • Paint before assembly<br/>         • Peindre avant assemblage<br/>         • Pintar antes del montaje<br/>         • Erst bemalen, dann zusammenbauen<br/>         • Dipinti prima dell'assemblaggio<br/>         • Покрасьте перед сборкой<br/>         • 組み立て前にペイントすること<br/>         • 組裝前塗裝</p> | <p> • Variant assembly<br/>         • Variante d'assemblage<br/>         • Variante de montaje<br/>         • Bauvariante<br/>         • Assemblaggio alternativo<br/>         • Варианты сборки<br/>         • 組み立てバリエーション<br/>         • 多种组装方式</p> |
| <p> • Build the number required, up to the limit shown<br/>         • Assembler le nombre requis, jusqu'à la limite indiquée<br/>         • Monta la cantidad requerida, hasta el límite mostrado<br/>         • Bau die benötigte Anzahl, bis zum angegebenen Limit<br/>         • Assembla il numero richiesto, fino al limite indicato<br/>         • Соберите нужное количество<br/>         • 示されている上限を超えないように、必要数を組み立てること<br/>         • 按要求数量組裝直至上限</p> | <p> • Repeat process<br/>         • Répéter l'étape<br/>         • Repetir pasos<br/>         • Vorgang wiederholen<br/>         • Ripeti il processo<br/>         • Повторите действие<br/>         • 同じ作業を繰り返すこと<br/>         • 重复步骤</p>   | <p> • Choice of parts<br/>         • Choix d'éléments<br/>         • Modelos de componentes<br/>         • Auswahl an Teilen<br/>         • Scelta di componenti<br/>         • Выбор деталей<br/>         • パーツの選択<br/>         • 选择部件</p>           |
| <p> • Use matching parts<br/>         • Utiliser les éléments correspondants<br/>         • Usa las piezas que correspondan<br/>         • Verwende die passenden Teile<br/>         • Usa le parti corrispondenti<br/>         • Используйте подходящие детали<br/>         • 適合するパーツを使用<br/>         • 使用匹配部件</p>  | <p> • Do not glue the components<br/>         • Ne pas coller les éléments<br/>         • No pegar los componentes<br/>         • Bitte die Teile nicht kleben<br/>         • Non incollare i componenti<br/>         • Не склеивайте детали<br/>         • このパーツは接着不可<br/>         • 请勿粘接</p>           | <p> • Stage complete<br/>         • Étape terminée<br/>         • Paso completado<br/>         • Schritt abgeschlossen<br/>         • Fase completa<br/>         • Этап завершен<br/>         • このステージの完成<br/>         • 完成</p>                       |

CONTENTS | CONTENU | CONTENIDO | INHALT | CONTENUTO | СОДЕРЖИМОЕ | コンテンツ | 内含板件

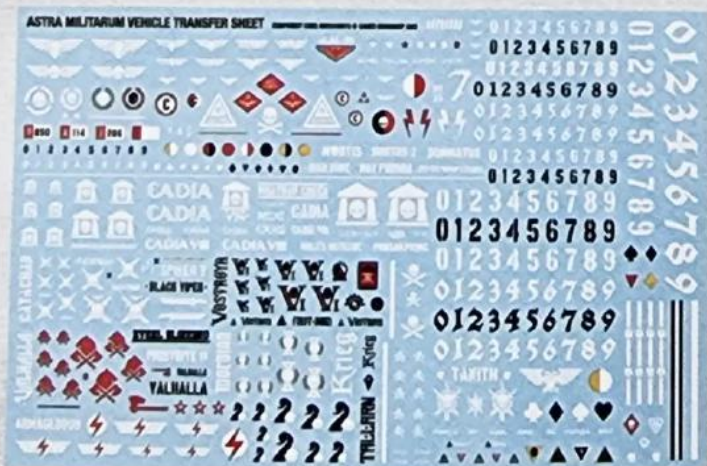
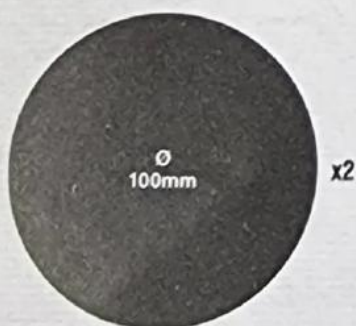
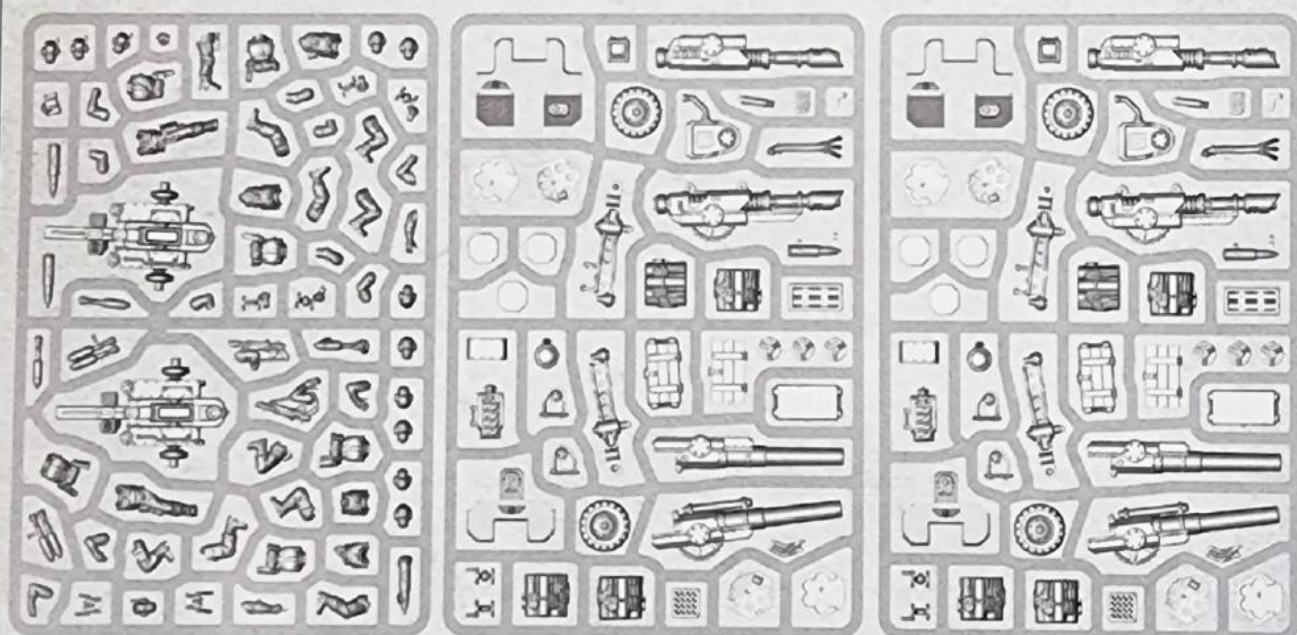



- Assemblies for build variants are colour coded.
- Les assemblages de variantes ont un code couleur.
- Las instrucciones para montajes alternativos se indican con un color diferente.
- Optionen für Bauvarianten sind farblich markiert.
- Le diverse varianti d'assemblaggio sono divise per colore.
- Различные варианты сборки выделены разными цветами.
- バリエーション違いの組み立ては色分けされている。
- 変体版拼装部件有颜色区分



**1 - 11**

**FIELD ORDNANCE BATTERY**

**BATTERIE D'ARTILLERIE | BATERIA DE ARTILLERIA DE CAMPANA | FELDGESCHÜTZBATTERIE**  
**BATTERIA D'ARTIGLIERIA MOBILE | БАТАРЕЯ ПОЛЕВОЙ АРТИЛЛЕРИИ**  
**フィールド・オードナンス・バッテリー | 野戦砲群**

**1 a x2**



1 b x2

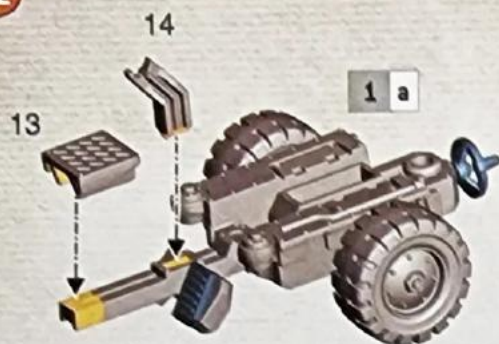

1 c x2

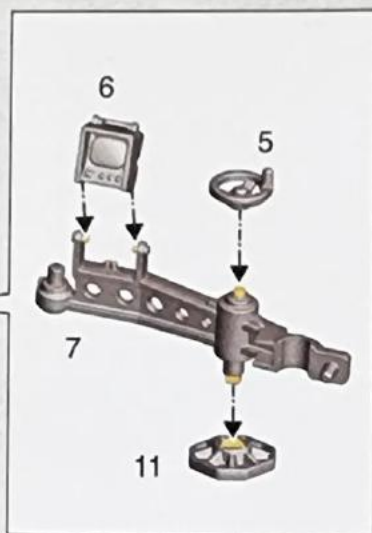

1 d x2

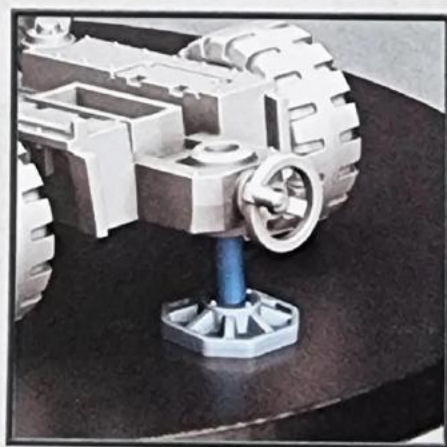
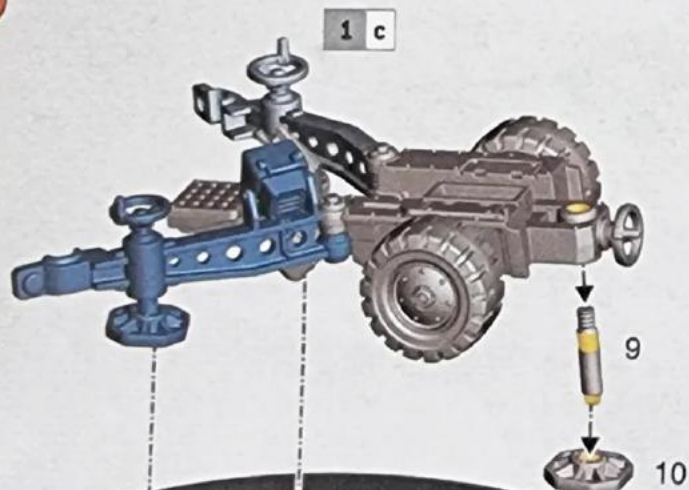

Ø 100mm

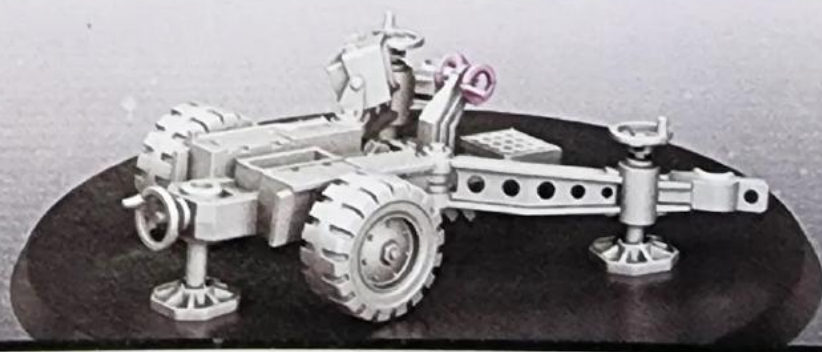
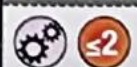
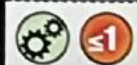
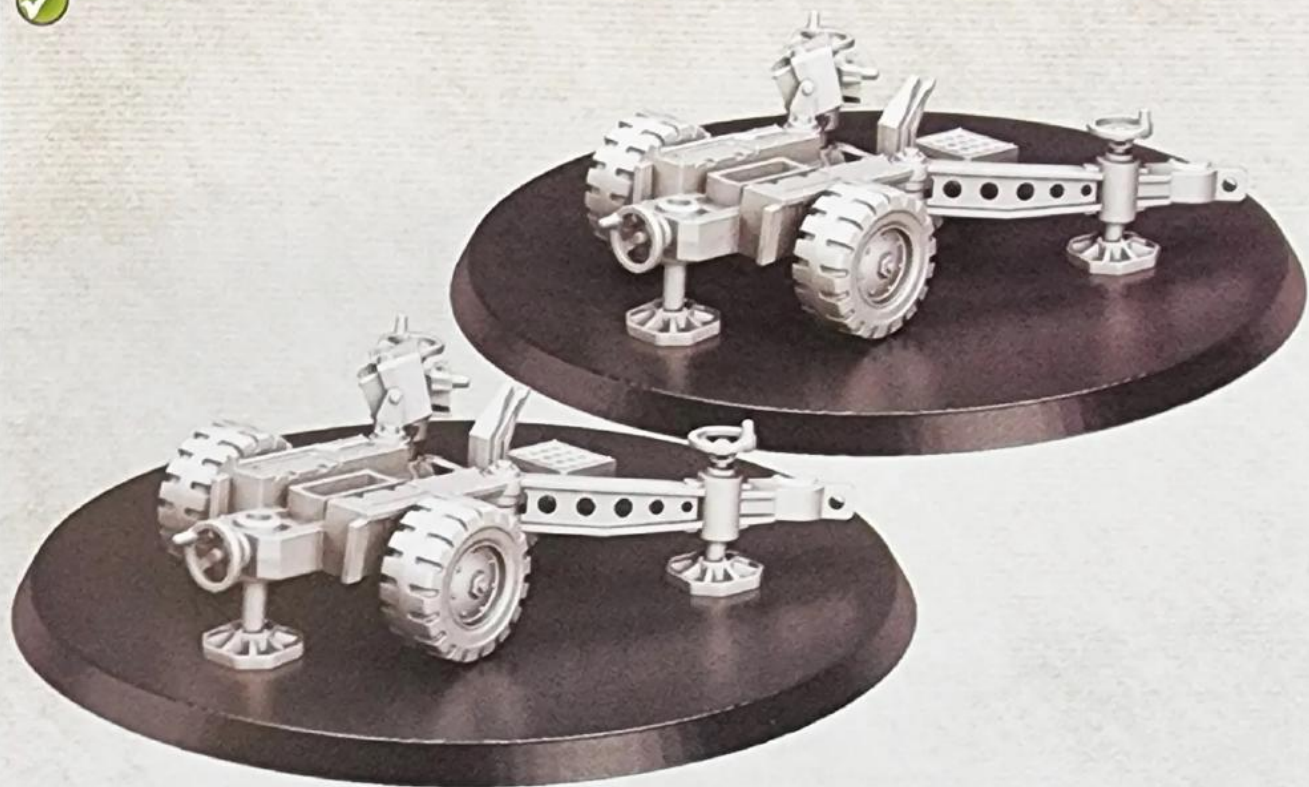

46

45

1

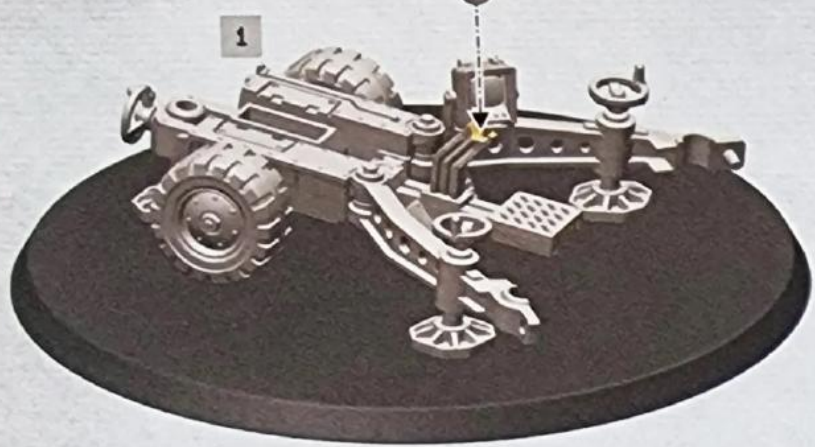

55

56

57

58



41

42



39

43

44



40

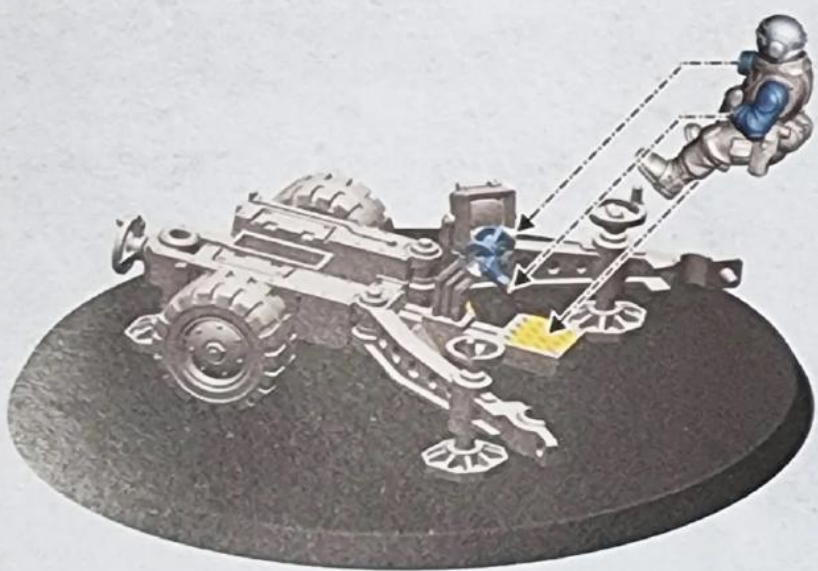
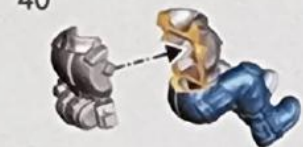

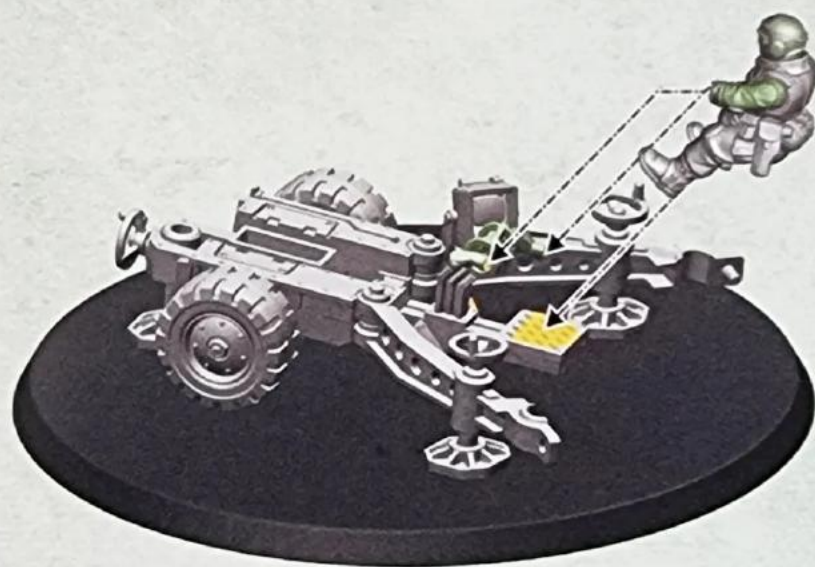
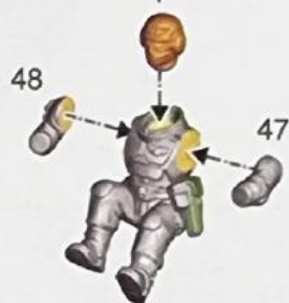
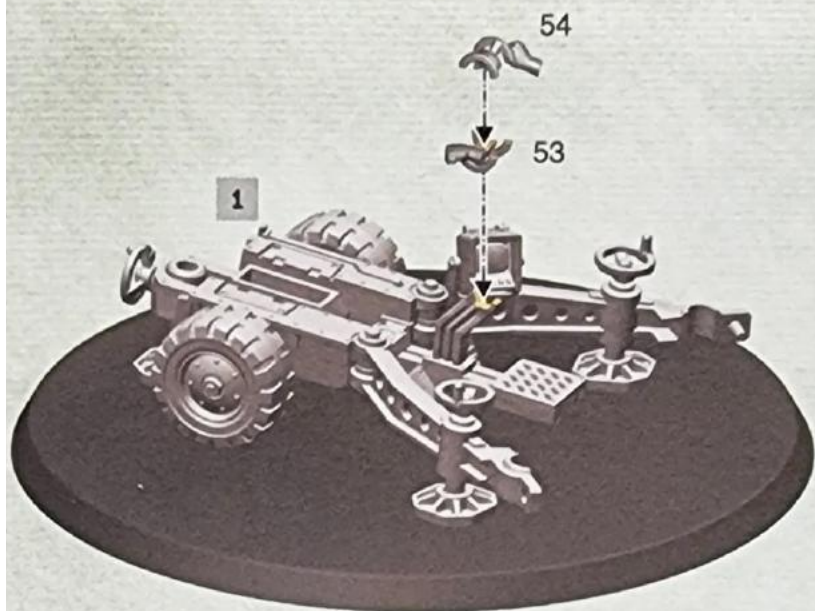



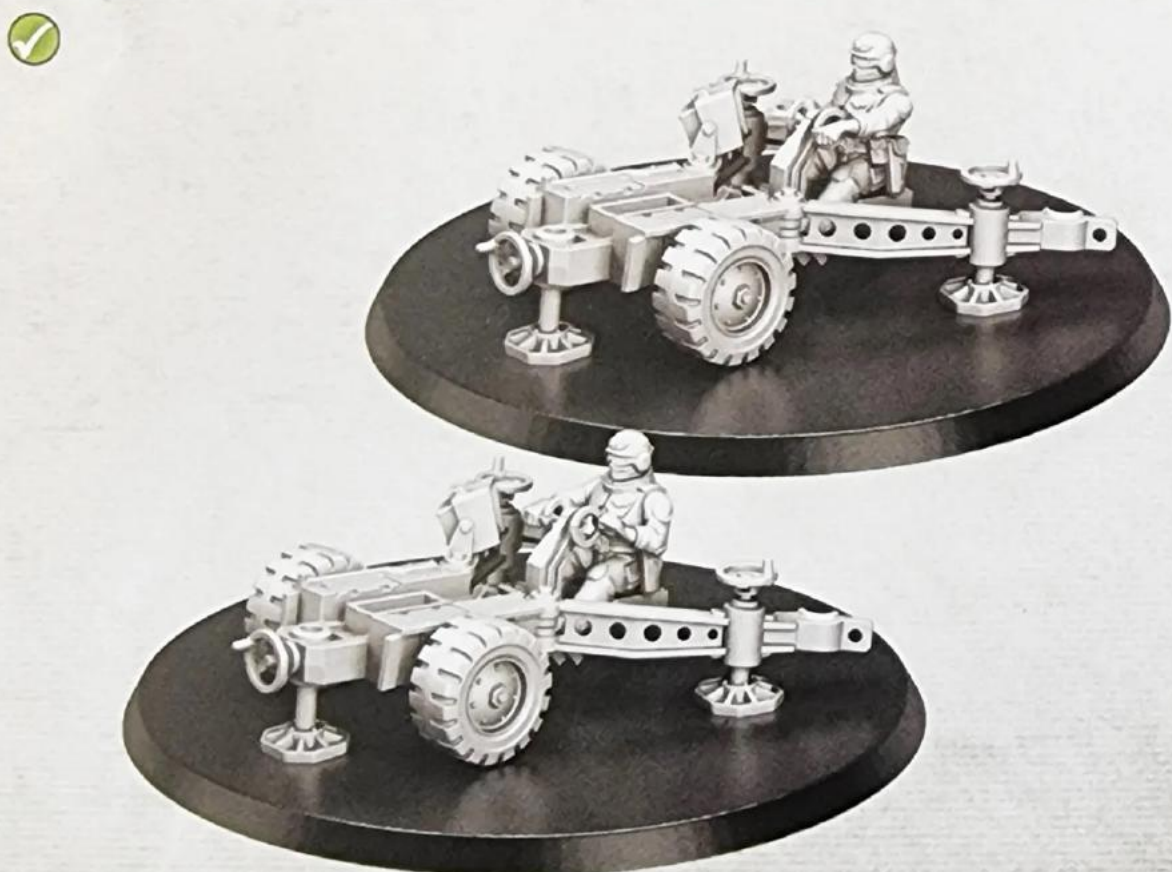
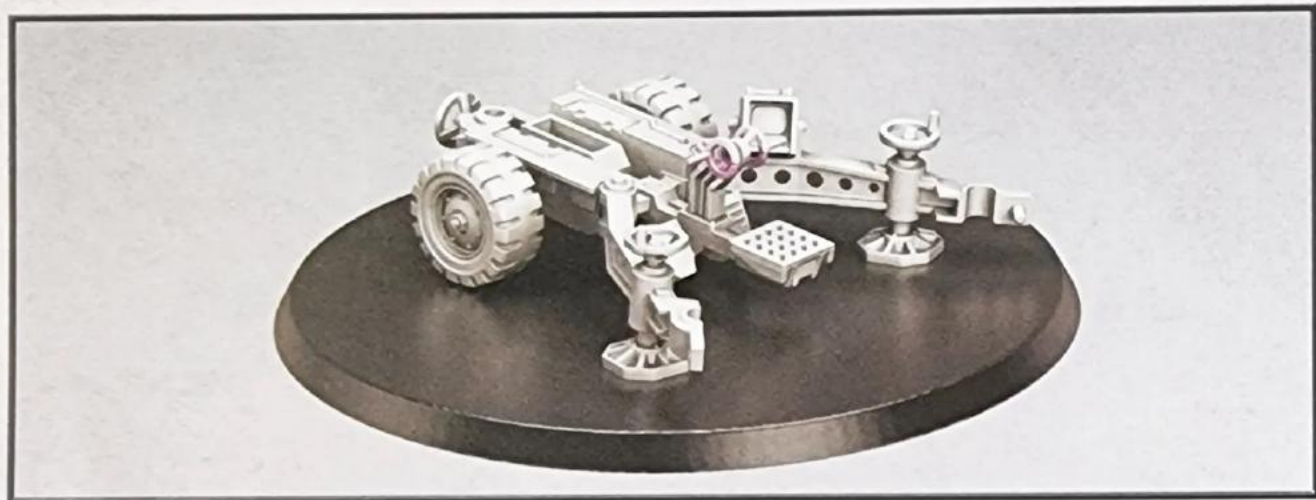
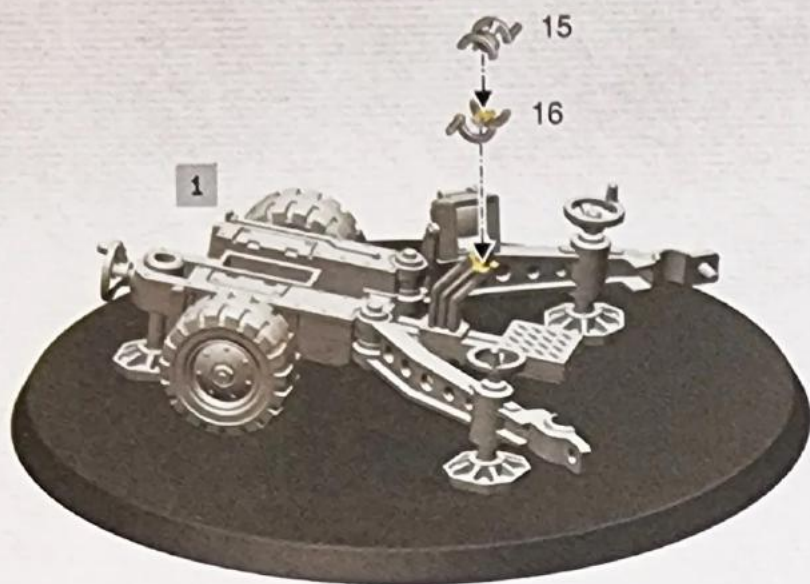

! 3-11 x2

3;6-11 ≤2



4;6-11 ≤2



5;6-11 ≤2



3 a

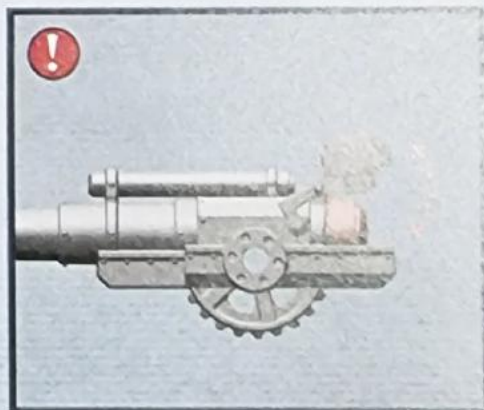

3 b

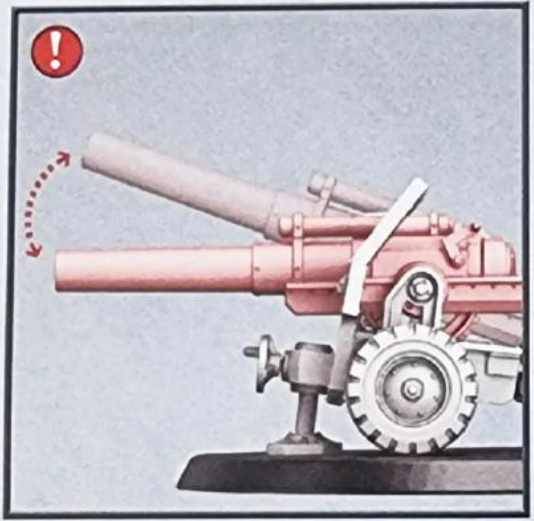
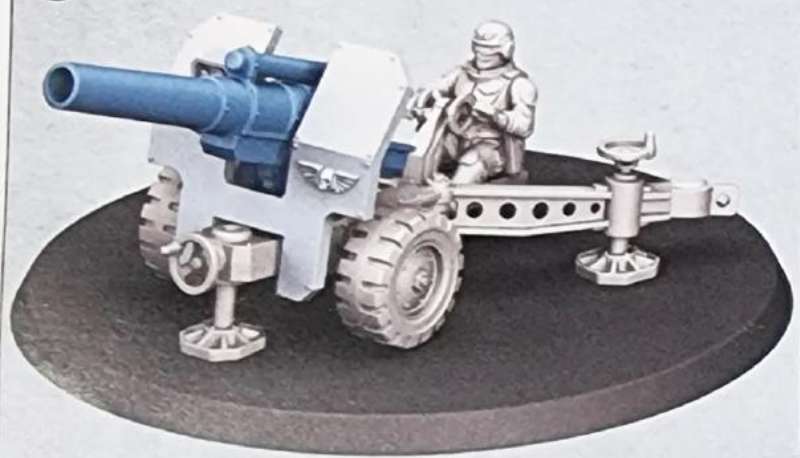
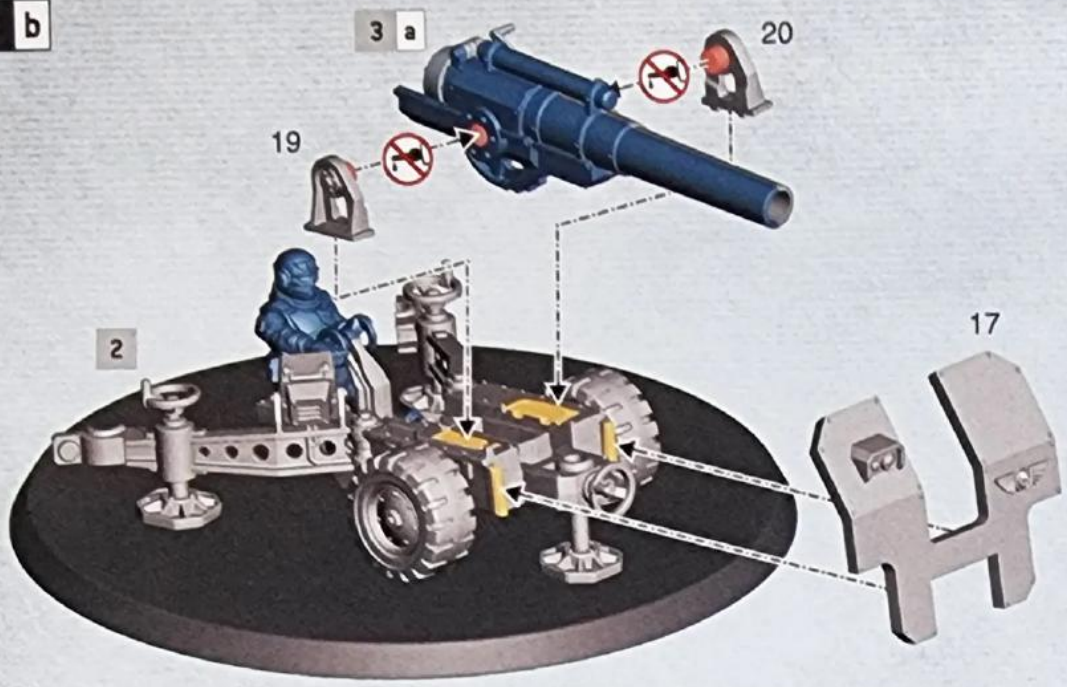

4 a

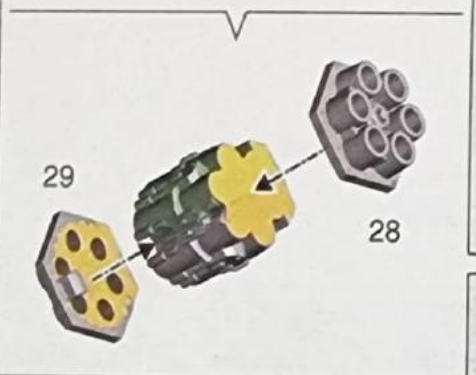
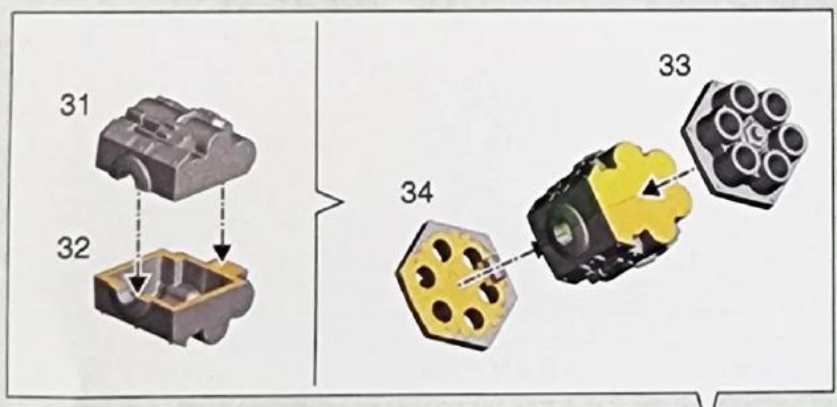
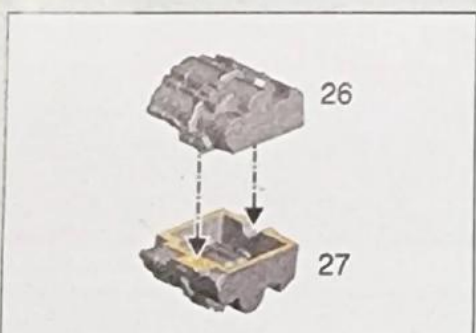

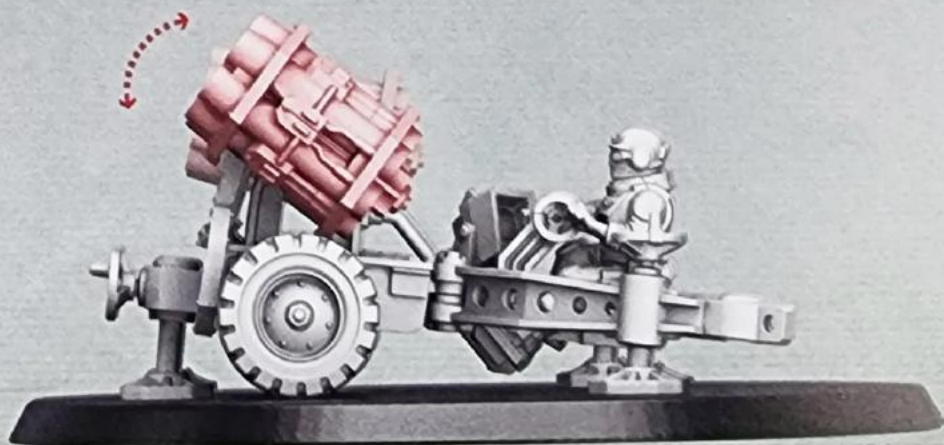
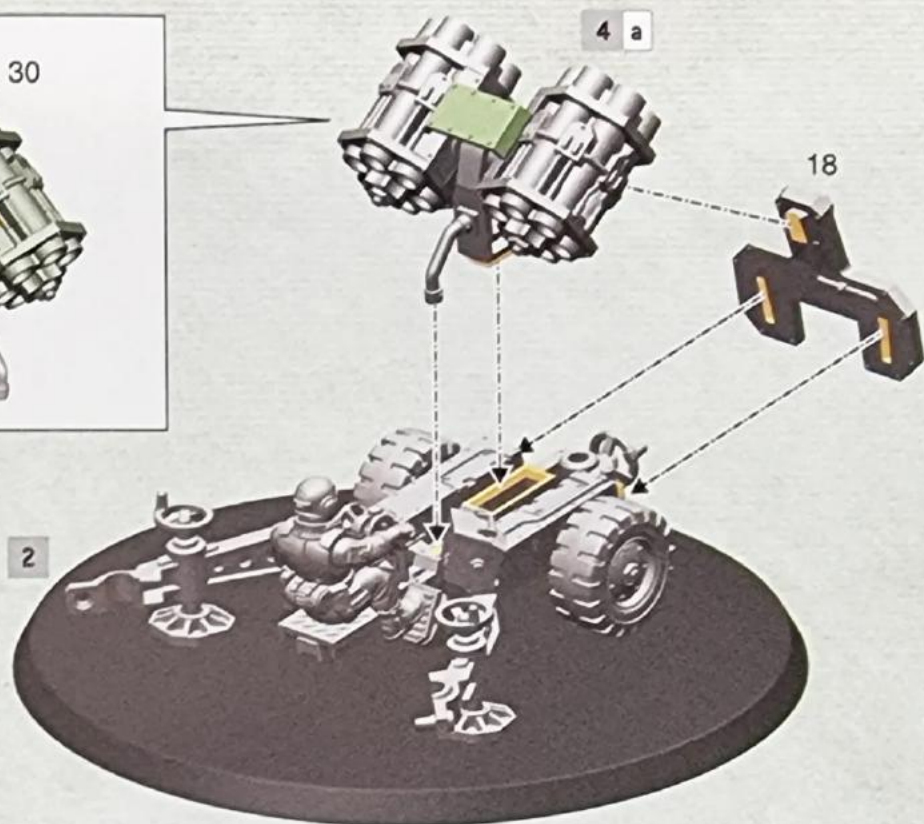
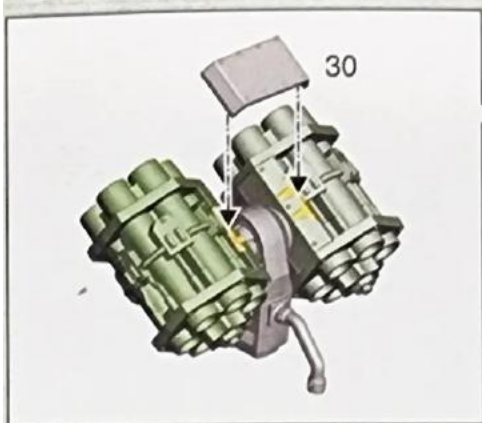

5 a



5 b

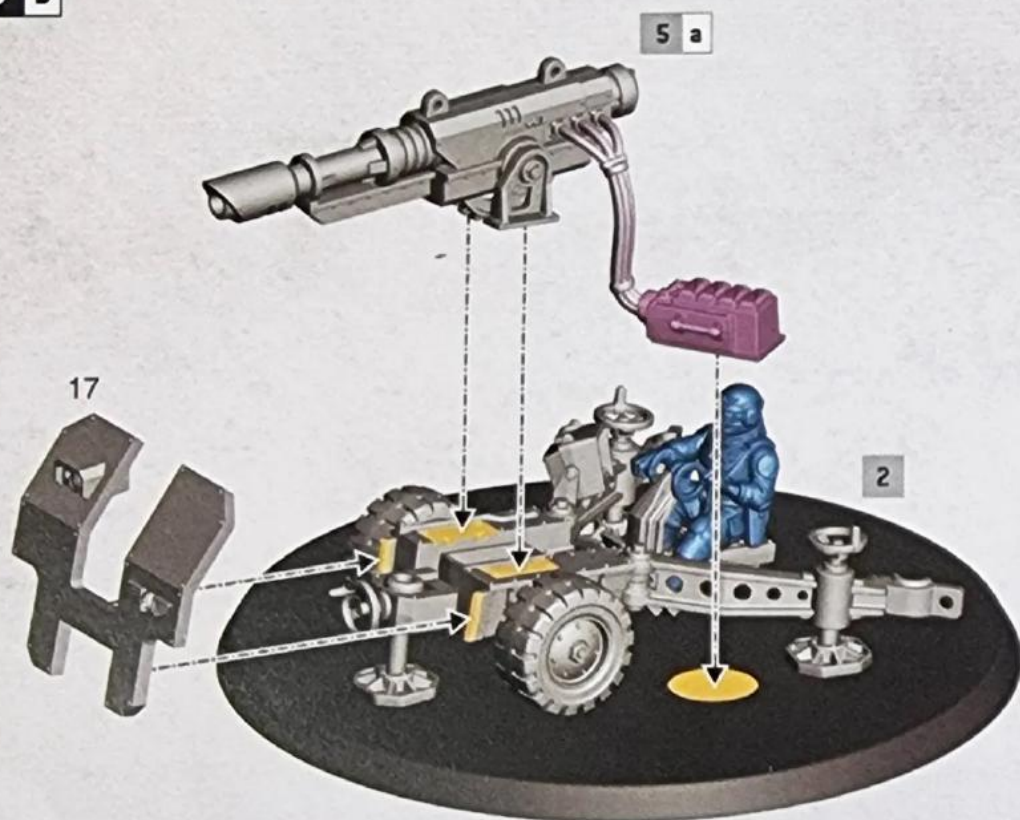

**6 a**

65 66

**6 b**

71



72



75



76



77

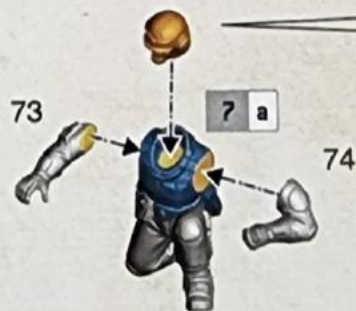

78

**7 a**
**7 b**

75



76



77



78





8 ≤2

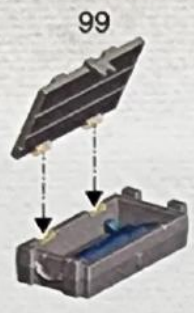
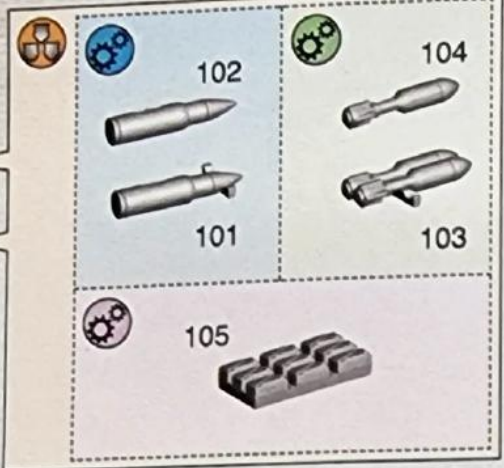

9 a



9 b



9 c

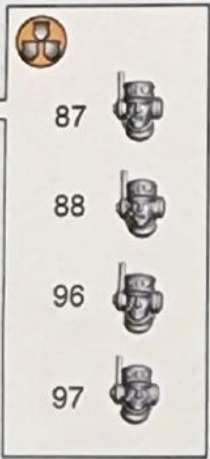

10

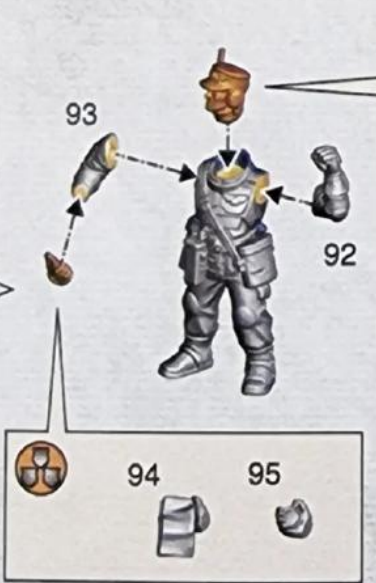



6



8



7



8



10



9

100



3/4/5

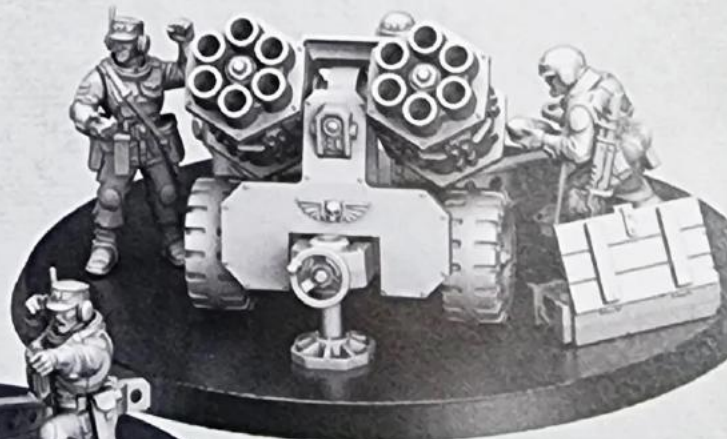
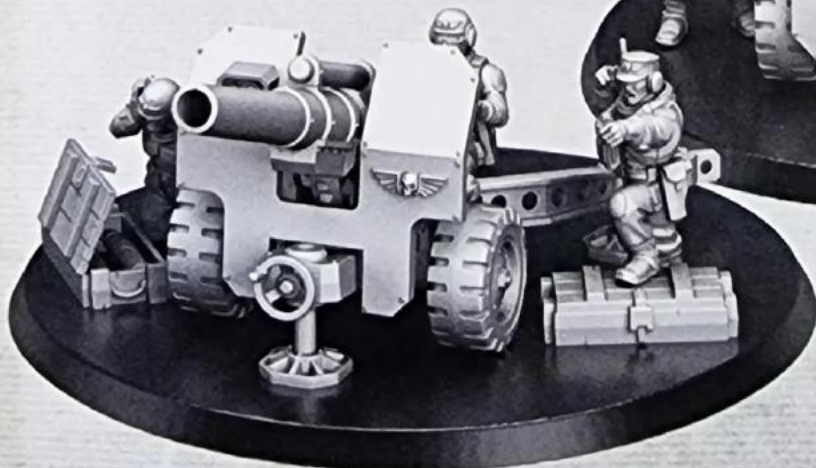
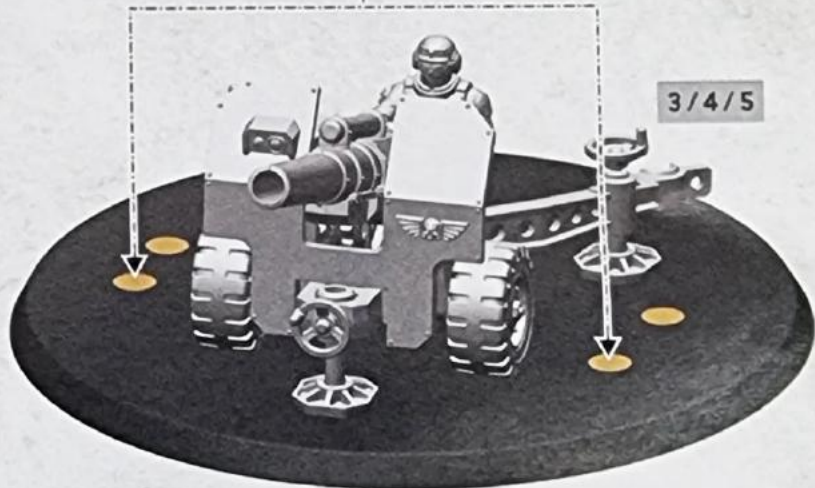



**ENG** Used alongside the core rules found on warhammer40000.com, the following essential rules will get your new unit on the battlefield. For the full rules for this unit, see the Codex relevant to your army.

**FRE** Utilisées avec les règles de base disponibles sur warhammer40000.com, les règles essentielles qui suivent vous permettront de jouer votre nouvelle unité. Pour connaître les règles complètes de cette unité, consultez le Codex correspondant à votre armée.

**SPA** Usadas junto con las reglas básicas que encontrarás en warhammer40000.com, las siguientes reglas esenciales te permiten desplegar esta nueva unidad en el campo de batalla. Para ver las reglas completas de esta unidad, consulta el Codex correspondiente a tu ejército.

**GER** Mit den Grundregeln auf warhammer40000.com und den folgenden grundlegenden Regeln kannst du deine neue Einheit direkt auf das Schlachtfeld führen. Die vollständigen Regeln für diese Einheit findest du im Codex deiner Armee.

**ITA** Con le seguenti regole fondamentali, usate assieme alle regole base che puoi trovare su warhammer40000.com, potrai schierare in campo la tua nuova unità. Per le regole complete di questa unità vedi il codex della tua armata.

**RUS** Следующие необходимые правила, используемые в сочетании с указанными на warhammer40000.com основными правилами, позволят вам задействовать новый отряд на игровом поле. Полные правила для этого отряда указаны в кодексе вашей армии.

**日・中** warhammer40000.com に掲載されているコアルールと一緒に使用することで、以下の簡易版ルールでこのユニットを戦場で使用することができます。このユニットの完全版ルールについては、アーマーに対応したコデックスを参照してください。

**中文** 与 warhammer40000.com 上的核心规则一起使用，以下基本规则适用于您在战场上的新单位。有关该单位的完整规则，请参阅与您的军队相关的圣典。

## FIELD ORDNANCE BATTERY

BATTERIE D'ARTILLERIE | BATERÍA DE ARTILLERÍA DE CAMPAÑA | FELDGESCHÜTZBATTERIE  
BATTERIA D'ARTIGLIERIA MOBILE | БАТАРЕЯ ПОЛЕВОЙ АРТИЛЛЕРИИ  
フィールド・オードナンス・バッテリー | 野战炮群



Ordnance Team



6"



4+



4+



3



4



6



3



6



4+

1

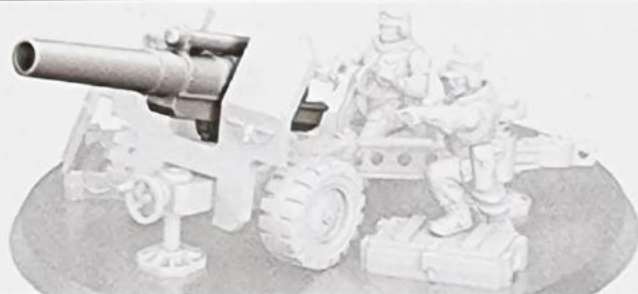

2



3



4



1	48"	D6	7	-2	2
2	48"	2	10	-4	D3+3
3	24"	1	3	0	1
4	48"	D6+6	6	-1	1



WARHAMMER.COM

Games Workshop Limited, Willow Road,  
Nottingham, NG7 2WS, UK

© Copyright Games Workshop Limited 2023.

