



Free Downloads of Build Instructions,  
Assembly Booklets & How To Guides

**BuildInstructions.com**

CHOOSE THE VARIANT YOU WANT TO BUILD • CHOISISSEZ LA VARIANTE À ASSEMBLER • ELIGE EL MODELO QUE VAYAS A MONTAR  
WÄHLE DIE VARIANTE, DIE DU BAUEN MÖCHTEST • SCEGLI LA VARIANTE CHE VUOI ASSEMBLARE • 組み立てたい方のミニチュアを選択する

**DWARF GYROBOMBER • GYROBOMBARDIER NAIN • GIROBOMBARDERO ENANO**  
**GYROBOMBER DER ZWERGE • GIROBOMBARDIERE DEI NANI • ドワーフ ジャイロボマー**



STEPS  
ÉTAPES  
PASOS  
SCHITTE  
FASI  
ステップ

1 - 6

**DWARF GYROCOPTER • GYROCOPTÈRE NAIN • GIROCÓPTERO ENANO**  
**GYROKOPTER DER ZWERGE • GIROCOTTERO DEI NANI • ドワーフ ジャイロコプター**



STEPS  
ÉTAPES  
PASOS  
SCHITTE  
FASI  
ステップ

1 &  
7 - 10

EXPLANATION OF SYMBOLS • EXPLICATION DES SYMBOLES • EXPLICACIÓN DE SÍMBOLOS  
ERLÄUTERUNG DER SYMBOLE • LEGENDA DEI SIMBOLI • アイコンの説明 • 符号说明



SPECIAL INSTRUCTION - PLEASE READ  
INSTRUCTIONS SPÉCIALES - LIRE ATTENTIVEMENT  
INSTRUCCIÓN ESPECIAL: POR FAVOR, LÉALA  
BESONDERE ANWEISUNG - BITTE LESEN  
ISTRUZIONI SPECIALI - LEGGI ATTENTAMENTE  
特記事項 - 必ず読んでください  
特殊说明 - 请阅读



DO NOT GLUE THE COMPONENTS  
NE PAS COLLER LES ÉLÉMENTS  
NO PEGAR LOS COMPONENTES  
BITTE DIE TEILE NICHT KLEBEN  
NON INCOLLARE I COMPONENTI  
パーツを接着しないこと  
请勿粘合部件



PAINT BEFORE ASSEMBLY  
PEINDRE AVANT ASSEMBLAGE  
PINTAR ANTES DEL MONTAJE  
ERST BEMALEN, DANN ZUSAMMENBAUEN  
DIPINGI PRIMA DELL'ASSEMBLAGGIO  
組み立て前にペイントすること  
組立前请先涂装



STAGE COMPLETE  
ÉTAPE TERMINÉE  
PASO COMPLETADO  
SCHRITT ABGESCHLOSSEN  
FASE COMPLETA  
このステップの完成例  
阶段完成



CHOICE OF PARTS  
CHOIX D'ÉLÉMENTS  
MODELOS DE COMPONENTES  
AUSWAHL AN TEILEN  
SCELTA DI COMPONENTI  
パーツの選択  
部件选择



ALTERNATE VIEW  
AUTRE ANGLE DE VUE  
VISTA ALTERNATIVA  
ALTERNATIVE ANSICHT  
VISUALE ALTERNATIVA  
別の角度から見た図  
其他视角



REPEAT PROCESS  
RÉPÉTER L'ÉTAPE  
REPETIR PASOS  
VORGANG WIEDERHOLEN  
RIPETI IL PROCESSO  
この手順を繰り返すこと  
重复过程



**READ THIS FIRST:** Before assembling your model kit please read through the instructions in this booklet carefully. A pair of plastic cutters is required to remove the plastic components in this kit from their frame. To assemble your model you will need plastic glue. Games Workshop sells Citadel Plastic Cutters and Citadel Plastic Glue, but does not recommend these products for use by children under the age of 16 without adult supervision.



**À LIRE EN PREMIER :** Avant de vous lancer dans l'assemblage de ce kit, veuillez lire attentivement les instructions de ce livret. Une pince coupante pour plastique est nécessaire pour détacher chaque élément de sa grappe. Vous aurez également besoin de colle plastique. Les lignes de moulage peuvent être retirées avec un couteau de modélisme. Games Workshop commercialise des Pincas Coupantes Citadel et de la colle plastique Citadel, mais n'en recommande pas l'usage pour les enfants de moins de 16 ans sans la supervision d'un adulte.



**LEER ANTES DE MONTAR:** Antes de montar el contenido del kit, lee estas instrucciones cuidadosamente. Para montar este kit te hará falta unas Tenazas Citadel para separar las piezas de la matriz de plástico y también necesitarás pegamento para plástico. Games Workshop vende herramientas de modelismo y pegamento para plástico Citadel, pero no recomienda estos productos a menores de 16 años sin la supervisión de un adulto.



**LIES DIES ZUERST:** Bitte lies diese Anleitung sorgfältig, bevor du mit dem Zusammenbau deiner Miniatur beginnst. Du benötigst einen Kunststoffseitenschneider, um die Kunststoffbauteile aus dem Gussrahmen herauszutrennen, und Kunststoffkleber, um die Miniatur zusammenzubauen. Games Workshop bietet Citadel-Kunststoffseitenschneider und Citadel-Kunststoffkleber an, empfiehlt aber, dass Kinder unter 16 Jahren diese nur unter Aufsicht eines Erwachsenen benutzen.



**LEGGI PRIMA QUESTO:** leggi attentamente queste istruzioni prima di assemblare i modelli. Per rimuovere dallo sprue i componenti di plastica di questo kit sono necessarie un paio di tronchesine. Per assemblare i modelli occorre la colla per plastica. Games Workshop vende Tronchesine Citadel e Colla per plastica Citadel, ma ne sconsiglia l'uso da parte dei minori di 16 anni senza la supervisione di un adulto.



**組み立て前にお読みください:** ミニチュアを組み立てる前に、この組み立て説明書をよく読んでください。このキットに含まれるプラパーツをランナーから切り出すには、ニッパーが必要です。ミニチュアを組み立てるには、プラ用セメントが必要です。ゲームズワークショップは、シタデル・ニッパーとシタデル・プラ用セメントを販売していますが、保護者の監督なしに16歳未満のお子様がこれらの製品を使用することを推奨していません。



**首先阅读:** 在组装您的整套模型之前, 请仔细阅读本手册中的说明。如想将本套模型中的塑料部件从框架上剪下来, 您需要使用塑料剪钳。在组装模型时您需要塑料胶水, Games Workshop出售Citadel塑料剪钳和Citadel塑料胶水, 但建议16岁以下儿童在成人监护下使用这些产品。



CITADEL PLASTIC GLUE THICK  
COLLE PLASTIQUE ÉPAISSE CITADEL  
PEGAMENTO PARA PLÁSTICO ESPESO  
CITADEL-KUNSTSTOFFKLEBER (DICKFLÜSSIG)  
COLLA PER PLASTICA DENSA CITADEL  
シタデル・プラ用セメント (濃厚タイプ)  
CITADEL 塑料稠胶



CITADEL PLASTIC GLUE THIN  
COLLE PLASTIQUE LIQUIDE CITADEL  
PEGAMENTO PARA PLÁSTICO FLUIDO  
CITADEL-KUNSTSTOFFKLEBER (DÜNNFLÜSSIG)  
COLLA PER PLASTICA FLUIDA CITADEL  
シタデル・プラ用セメント (流し込みタイプ)  
CITADEL 塑料薄胶



CITADEL PLASTIC CUTTERS  
PINCAS COUPANTES POUR PLASTIQUE CITADEL  
TENAZAS CITADEL  
CITADEL-KUNSTSTOFFSEITENSCHNEIDER  
TRONCHESINE CITADEL  
シタデル・ニッパー  
CITADEL 塑料剪钳



Follow step 1 for all variants • Suivre l'étape 1 pour toutes les variantes  
 Sigue el paso 1 para todas las variantes • Folge Schritt 1 für alle Varianten  
 Segui la fase 1 per tutte le varianti • どのバリエーションもステップ1に従う

**1**

**PILOT AND COCKPIT ASSEMBLY • ASSEMBLAGE DU PILOTE & DU COCKPIT • MONTAJE DEL PILOTO Y LA CABINA  
 ZUSAMMENBAU VON PILOT UND COCKPIT • ASSEMBLAGGIO DEL PILOTA E DELLA CABINA • パイロットとコックピットの組み立て**

**A**

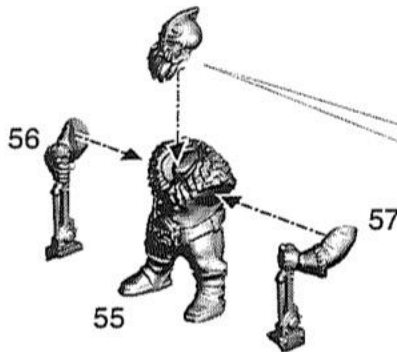

58

59

60

61



Choice of heads • Choix de têtes • Modelos de cabezas  
 Auswahl an Köpfen • Scelta di teste • 好きな頭を選択

**B**

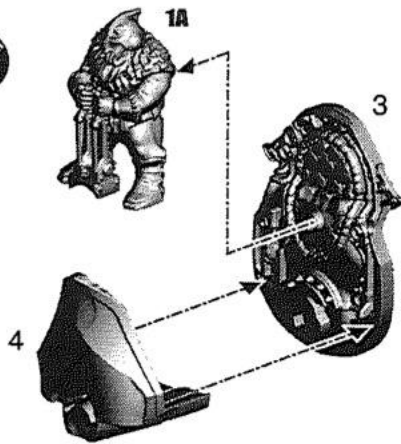

**C**

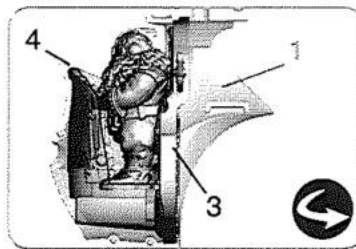
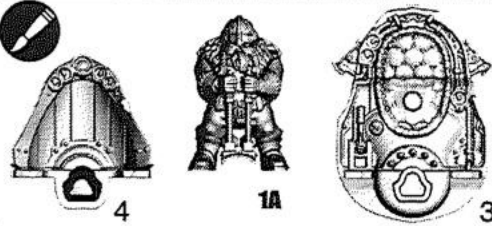
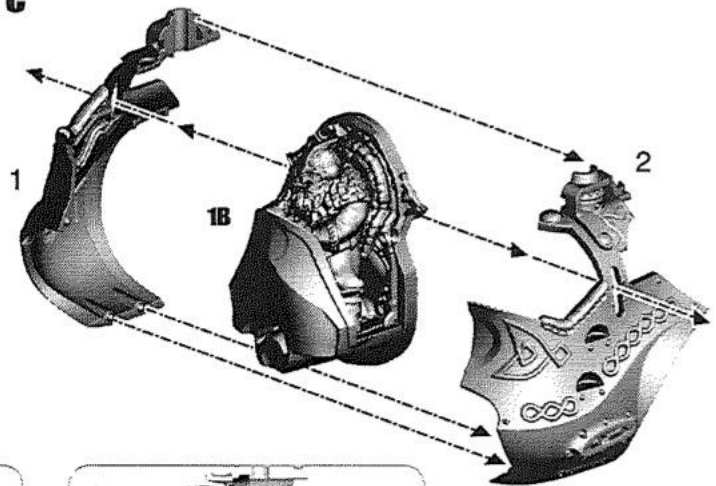

**D**

51



52



53



54



Choice of symbols • Choix de symboles • Modelos de símbolos  
 Auswahl an Symbolen • Scelta di simboli • 好きなシンボルを選択

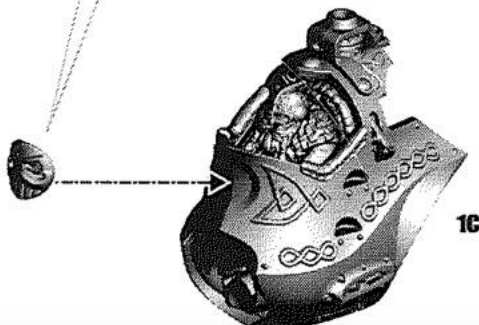

**E**

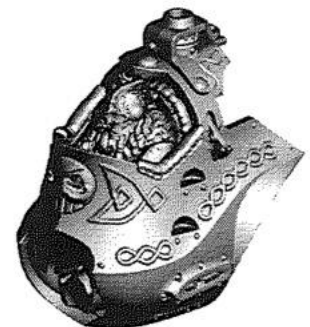

2

GUN AND NACELLE ASSEMBLY • ASSEMBLAGE DES ÉLICES & DU CANON • MONTAJE DEL CAÑÓN Y LA CUBIERTA DEL MOTOR  
ZUSAMMENBAU VON KANONE UND RUMPF • ASSEMBLAGGIO DI ARMA E GONDOLE MOTORI • 銃とエンジン室の組み立て

A

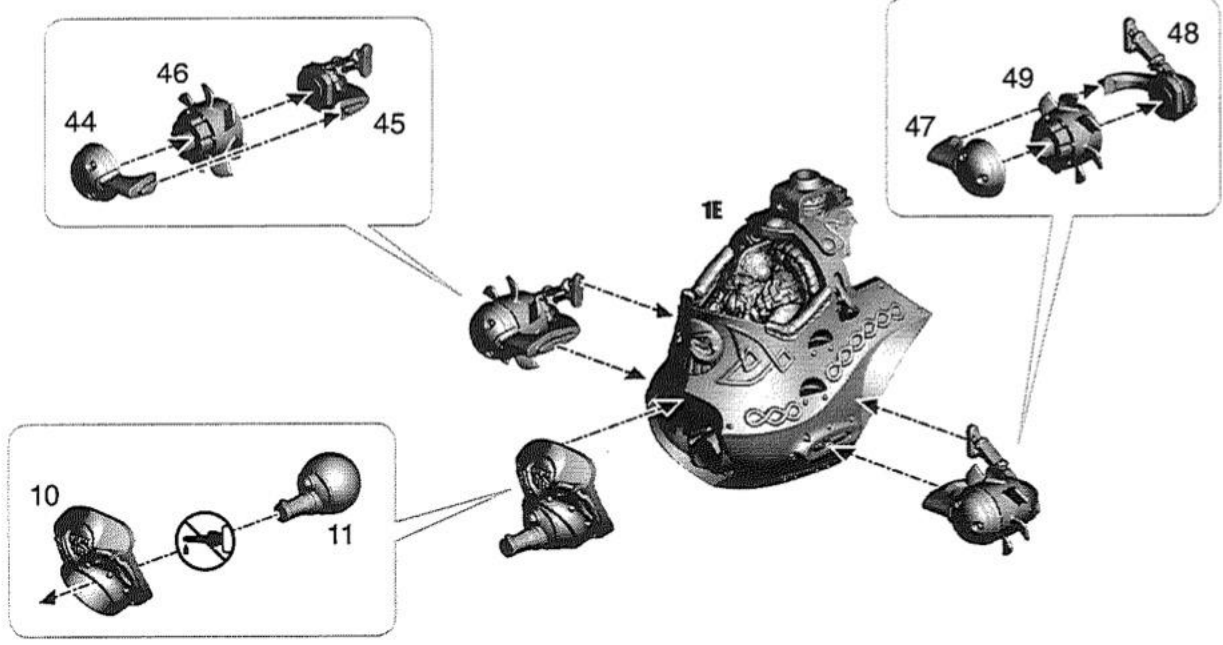

B

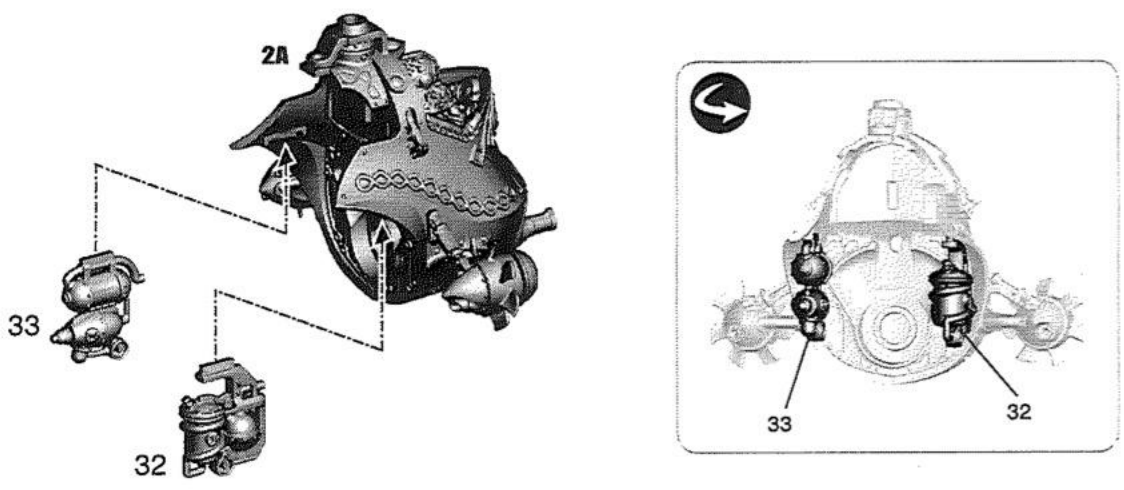

C

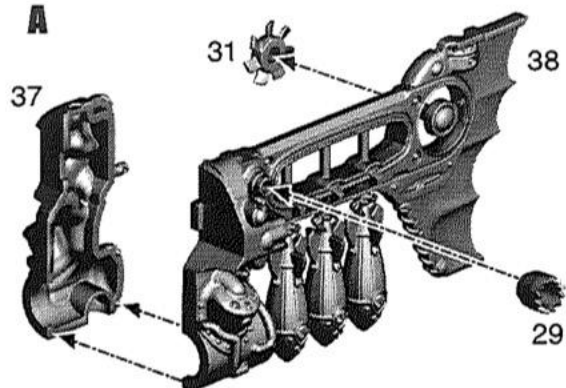
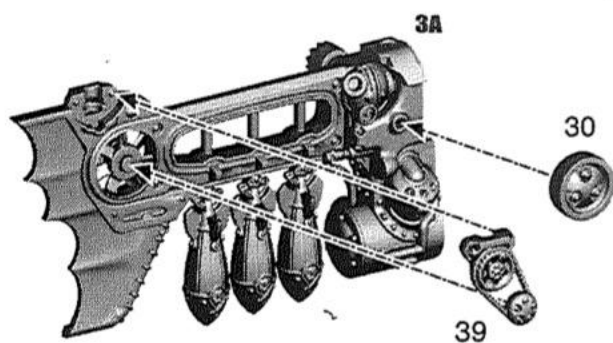
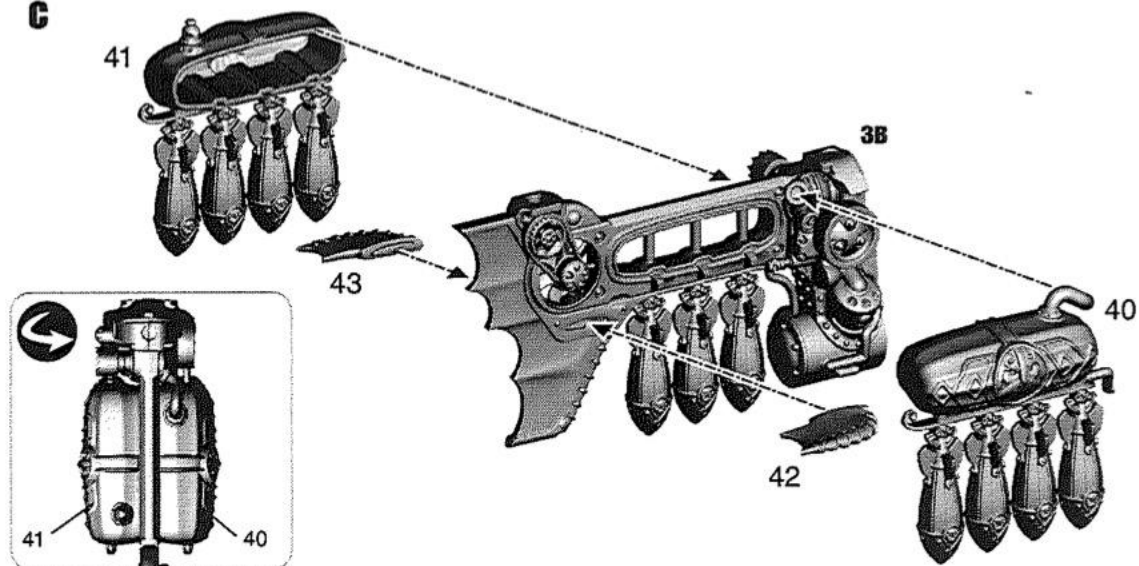
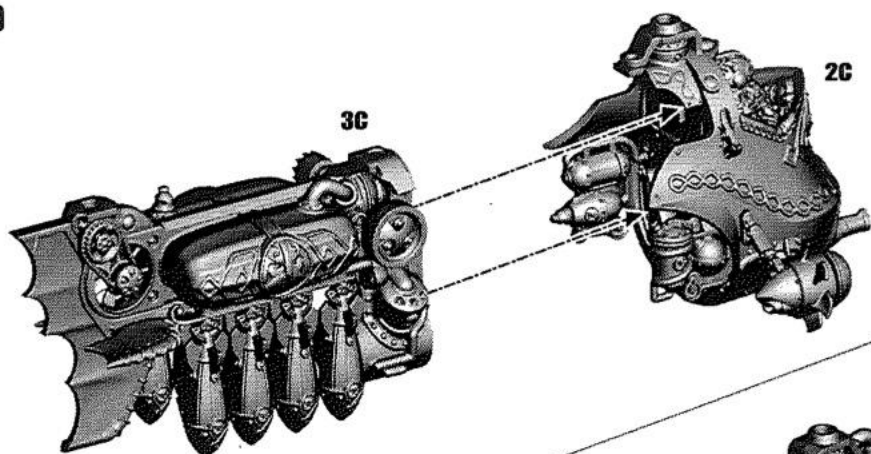
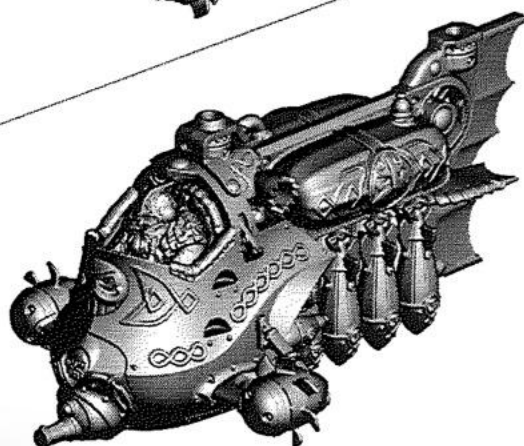

**3****ENGINE AND TAIL ASSEMBLY • ASSEMBLAGE DU MOTEUR ET DE LA QUEUE • MONTAJE DEL MOTOR Y LA COLA  
ZUSAMMENBAU VON MOTOR UND HECK • ASSEMBLAGGIO DI MOTORE E CODA • エンジンとテールの組み立て****A****B****C****D****E**

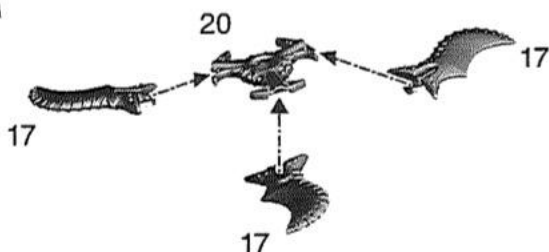

**4****REAR ROTOR ASSEMBLY • ASSEMBLAGE DU ROTOR ARRIÈRE • MONTAJE DEL ROTOR TRASERO****ZUSAMMENBAU DES HINTEREN ROTORS • ASSEMBLAGGIO DEL ROTORE POSTERIORE • 後部回転翼の組み立て****A**

Ensure correct parts are used in Stage 4 and 5

Assurez-vous que les bons éléments sont utilisés aux étapes 4 &amp; 5

Asegúrate de utilizar las piezas correctas en los pasos 4 y 5

Achte bei den Schritten 4 und 5 besonders darauf, die korrekten Teile zu verwenden

Assicurati di usare i componenti giusti nelle fasi 4 e 5

ステップ4と5では正しいパーツを必ず使用すること

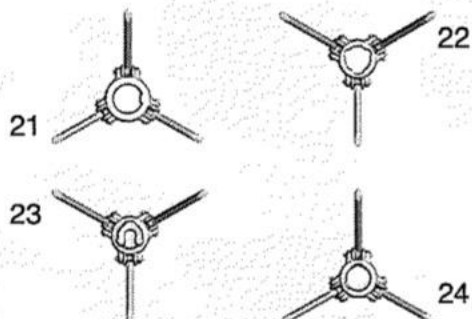
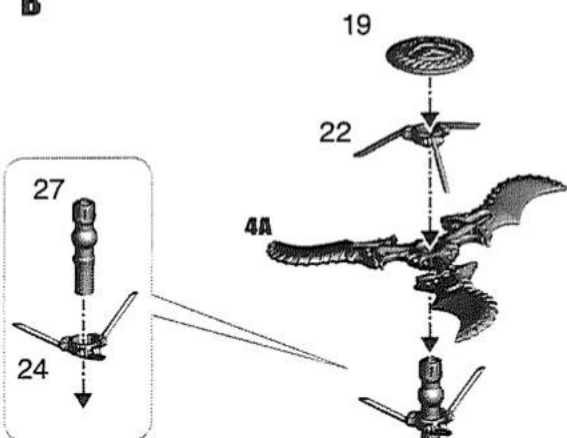
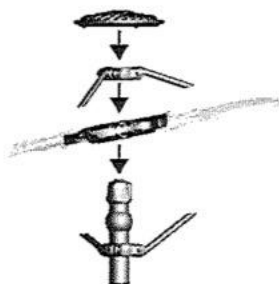
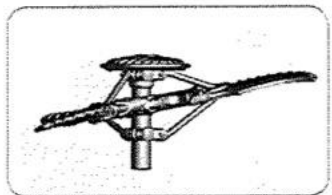
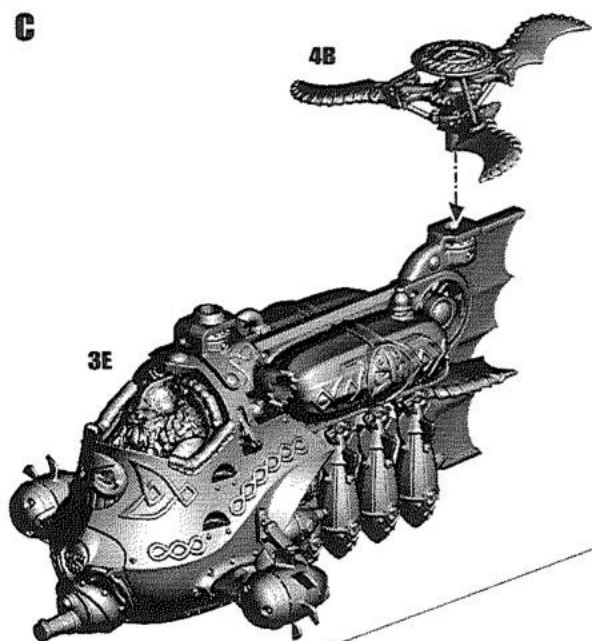
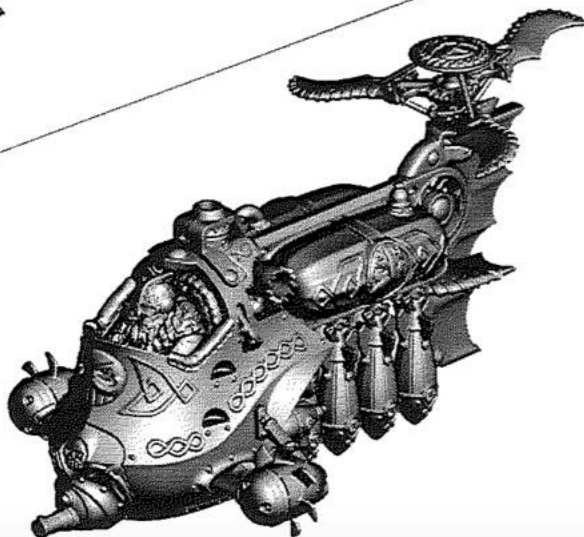
**B**Assemble parts in order shown  
Assembler les pièces dans l'ordre  
indiquéMonta las piezas en el orden  
mostradoBaue die Teile in der gezeigten  
Reihenfolge zusammenAssembla i componenti nell'ordine  
indicato図に示された順番でパーツを組み  
立てること**C****D**

**5**

**FRONT ROTOR ASSEMBLY • ASSEMBLAGE DU ROTOR PRINCIPAL • MONTAJE DEL ROTOR FRONTAL  
ZUSAMMENBAU DES VORDEREN ROTORS • ASSEMBLAGGIO DEL ROTORE FRONTALE • 前部回転翼の組み立て**

**A**

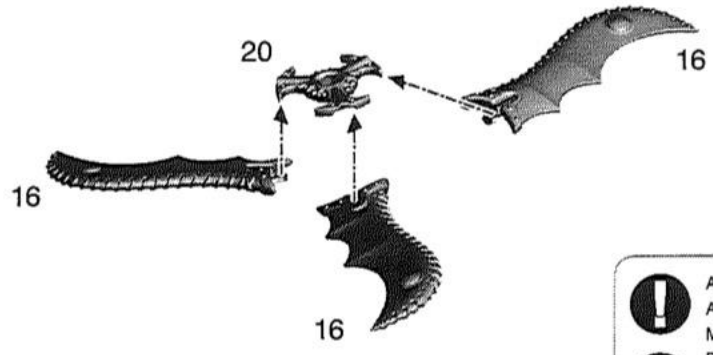

**!** Assemble parts in order shown  
 Assembler les pièces dans l'ordre indiqué  
 Monta las piezas en el orden mostrado  
**↻** Baue die Teile in der gezeigten Reihenfolge zusammen  
 Assembla i componenti nell'ordine indicato  
 図に示された順番でパーツを組み立てること

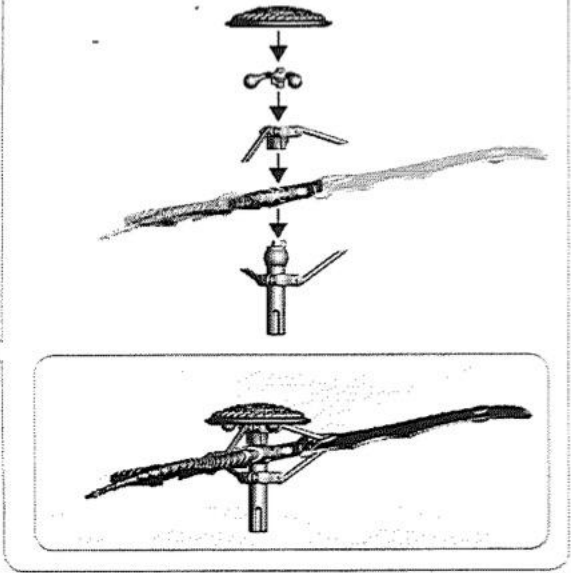

**B**

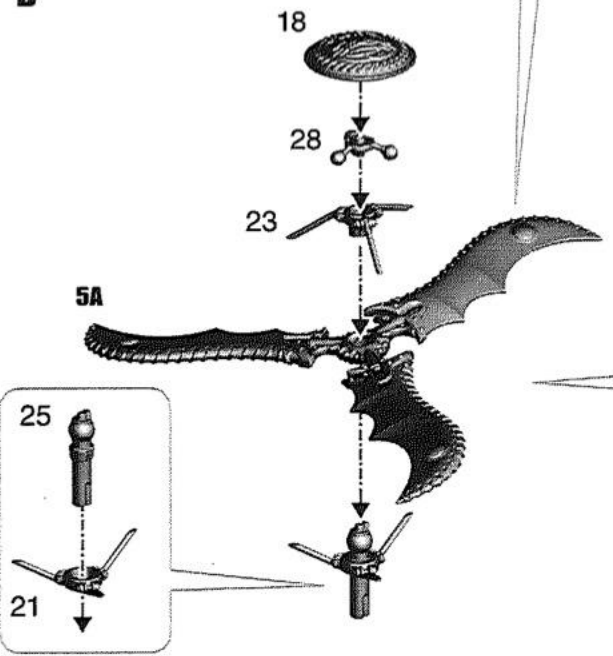

**C**

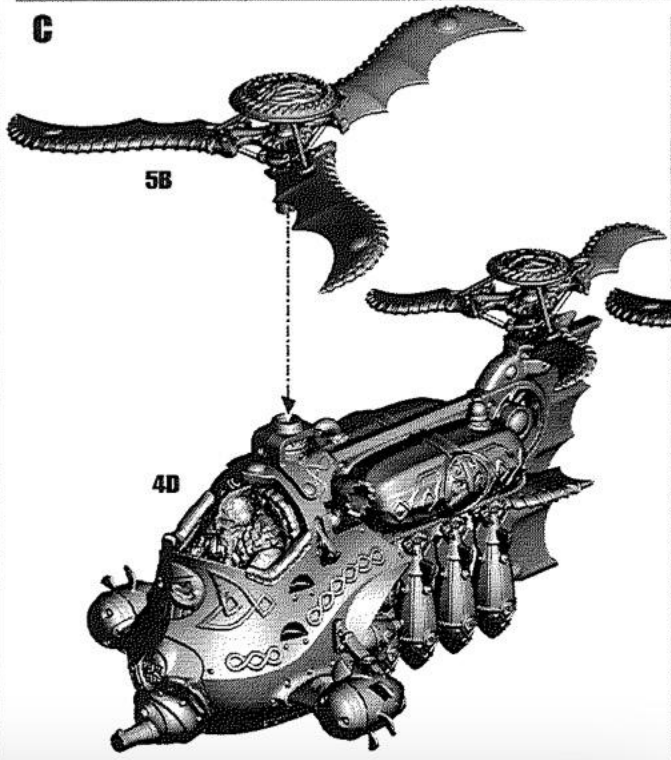

**D**





6

FLYING BASE ASSEMBLY • ASSEMBLAGE DU SOCLE VOLANT • MONTAJE DE LA PEANA VOLADORA

ANBRINGEN AUF DEM FLUGBASE • ASSEMBLAGGIO DELLA BASETTA PER MODELLI VOLANTI • フラングベースの組み立て

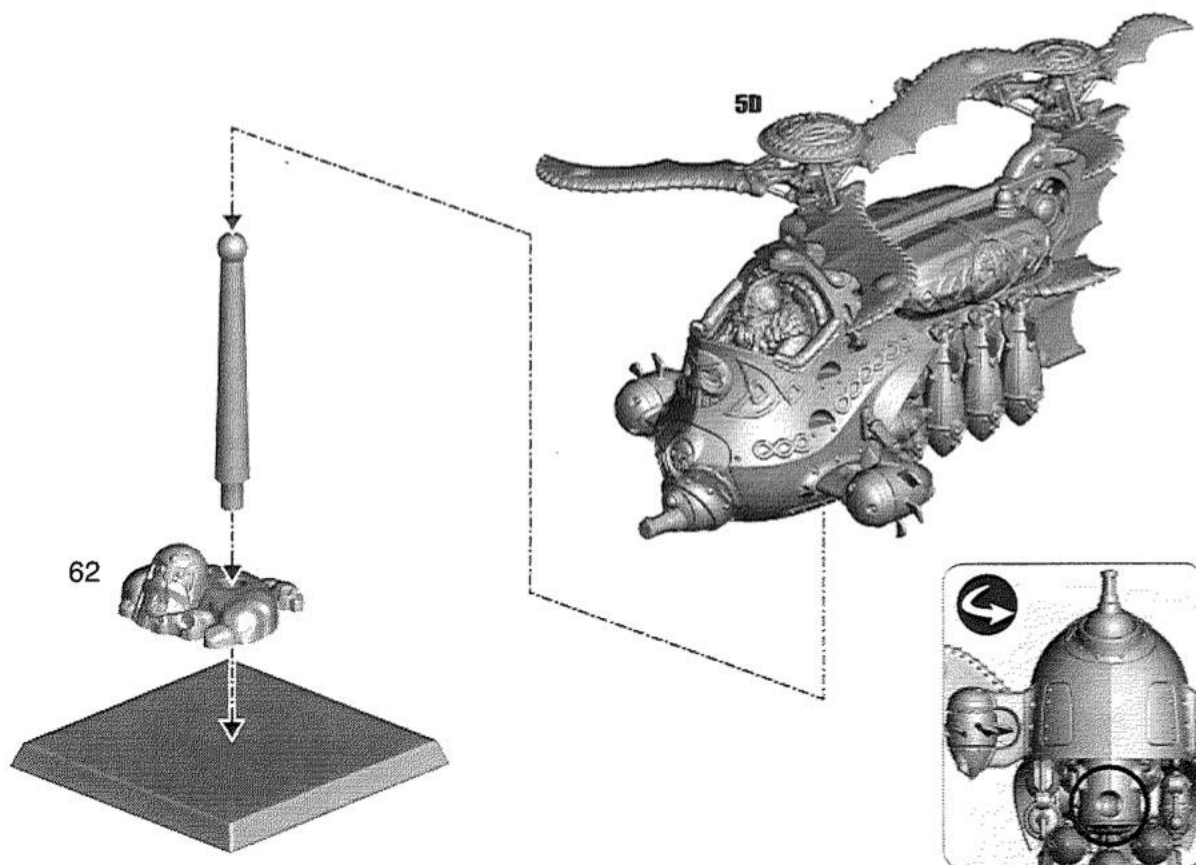



FINISHED ASSEMBLY • ASSEMBLAGE TERMINÉ • MONTAJE ACABADO

FERTIGER ZUSAMMENBAU • ASSEMBLAGGIO COMPLETO • 完成例

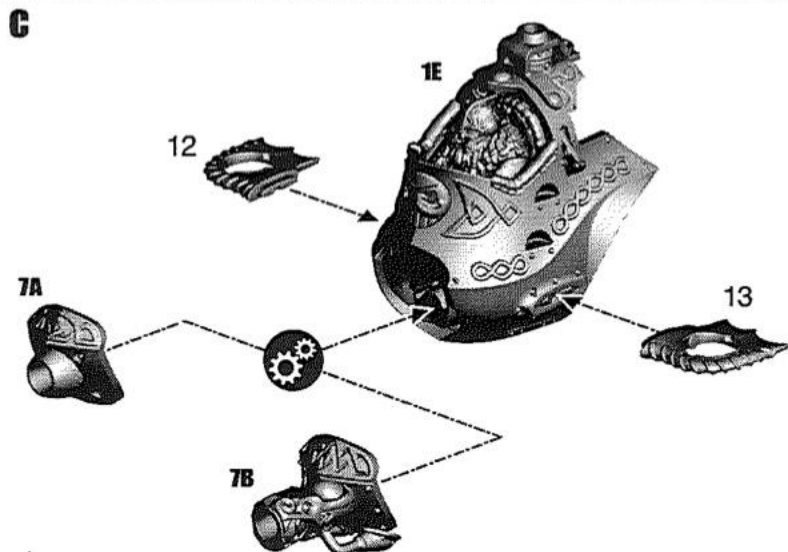
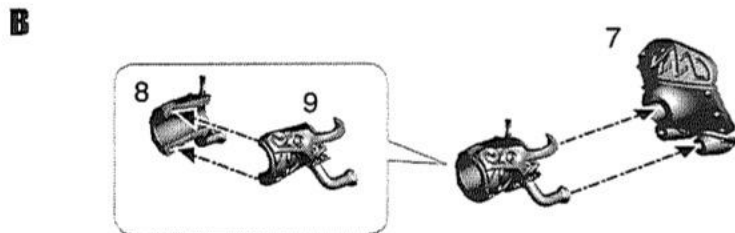
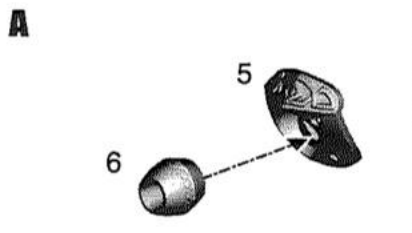

**7** GUN AND CANARD ASSEMBLY • ASSEMBLAGE DU CANON ET DES AILERONS • MONTAJE DEL CAÑÓN Y ALA CANARD  
 ZUSAMMENBAU VON KANONE UND CANARD • ASSEMBLAGGIO DELL'ARMA E DELLE ALETTE • 銃とカナードの組み立て



 **Choice of Steam Gun (7A) or Brimstone Gun (7B)**  
 Choix de Canon à Vapeur (7A) ou Canon à Souffre (7B)  
 Elige montar un Cañón de vapor (7A) o un Cañón de azufre (7B)  
 Dampfkanone (7A) oder Schwefelkanone (7B)  
 Scelta fra cannone a vapore (7A) e cannone a zolfo (7B)  
 スチームガン (7A) かブリムストーンガン (7B)を選択

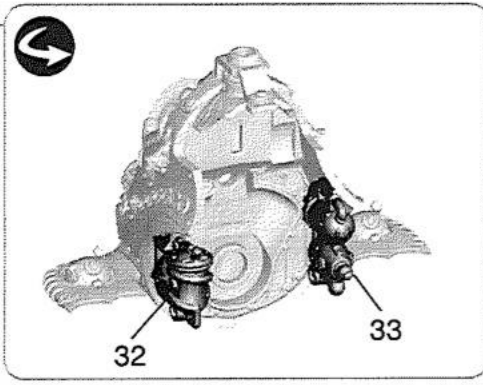
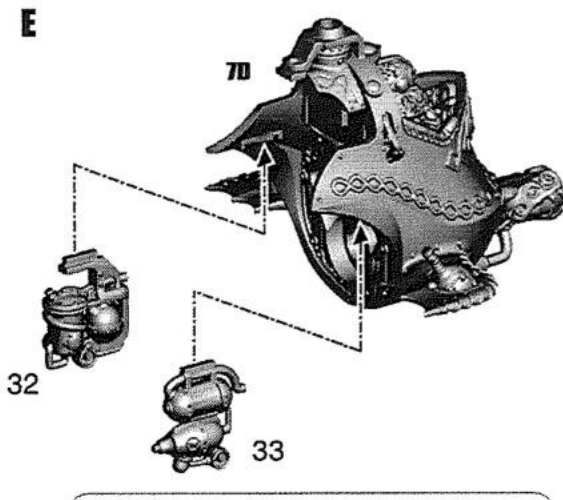
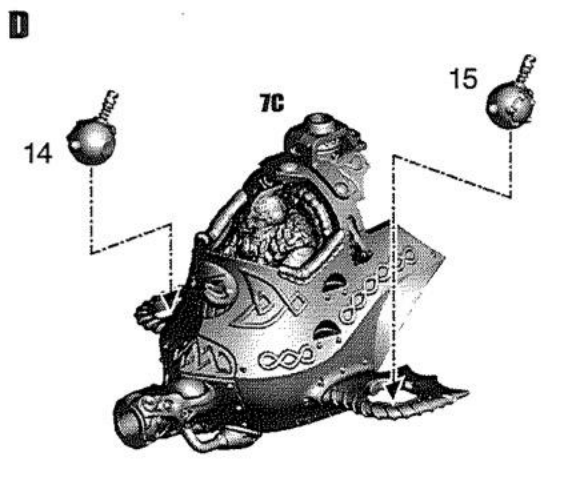

**8**

ENGINE AND TAIL ASSEMBLY • ASSEMBLAGE DU MOTEUR ET DE LA QUEUE • MONTAJE DEL MOTOR Y LA COLA  
 ZUSAMMENBAU VON MOTOR UND HECK • ASSEMBLAGGIO DI MOTORE E CODA • エンジンとテールの組み立て

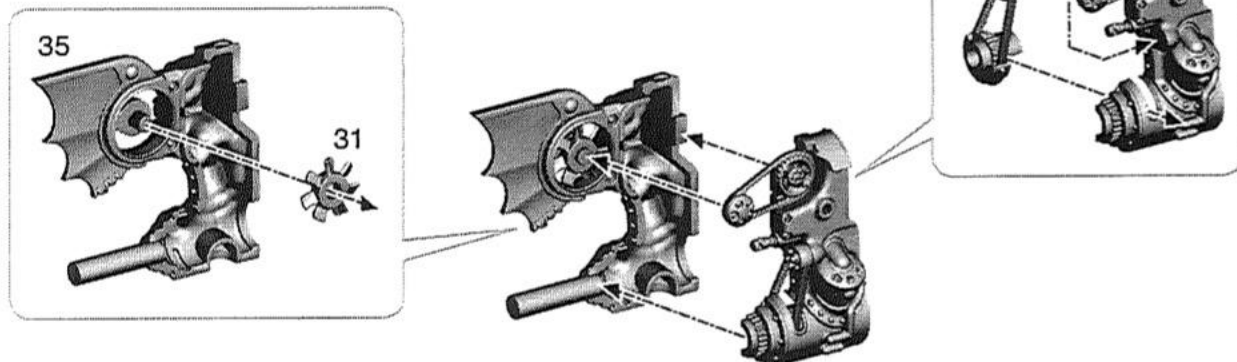
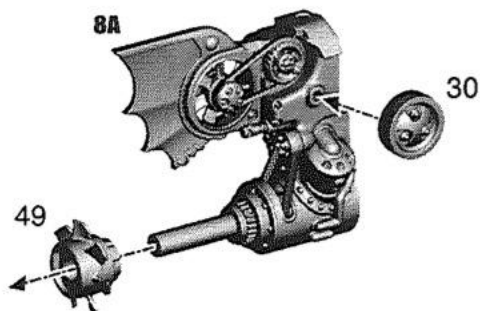
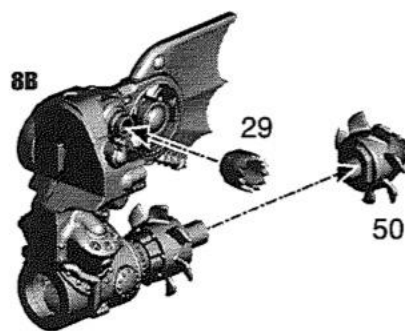
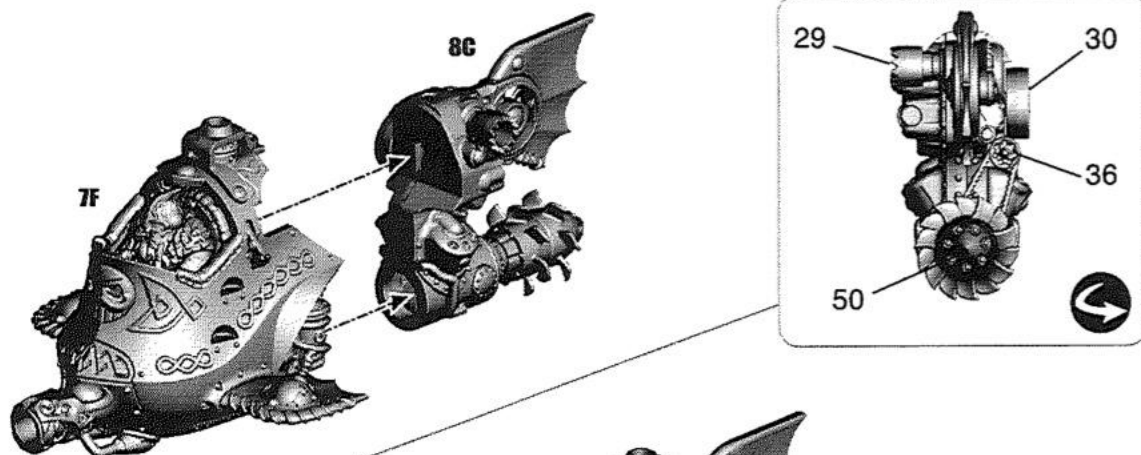
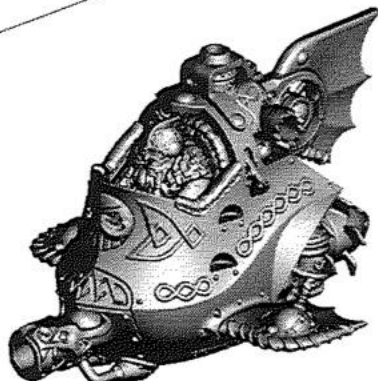
**A****B****C****D****E**

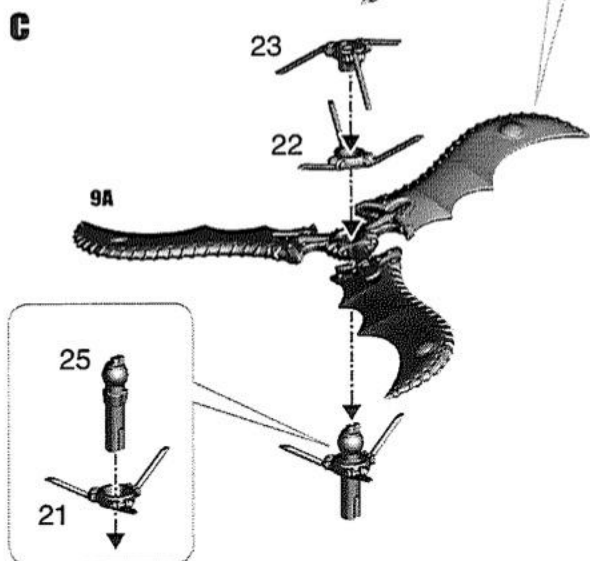
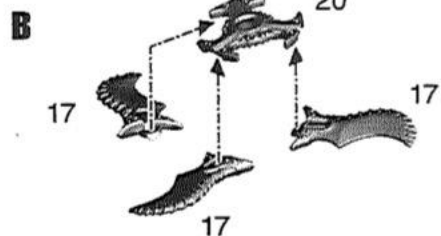
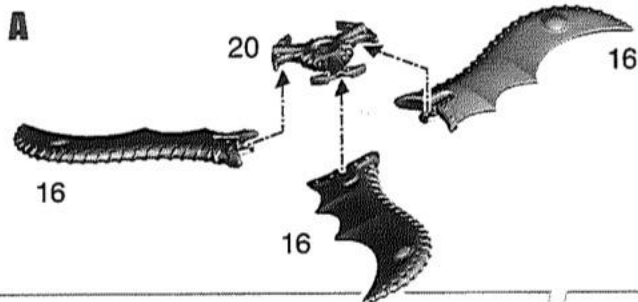
**9**
**ROTOR ASSEMBLY • ASSEMBLAGE DU ROTOR • MONTAJE DEL ROTOR  
 ZUSAMMENBAU DES ROTORS • ASSEMBLAGGIO DEL ROTORE • 回転翼の組み立て**

Ensure correct parts are used in Stage 9  
 Assurez-vous que les bons éléments sont utilisés à l'étape 9  
 Asegúrate de utilizar las piezas correctas en los pasos 9  
 Achte bei Schritt 9 besonders darauf, die korrekten Teile zu verwenden  
 Assicurati di usare i componenti giusti nelle fasi 9  
 ステップ9では正しいパーツを必ず使用すること

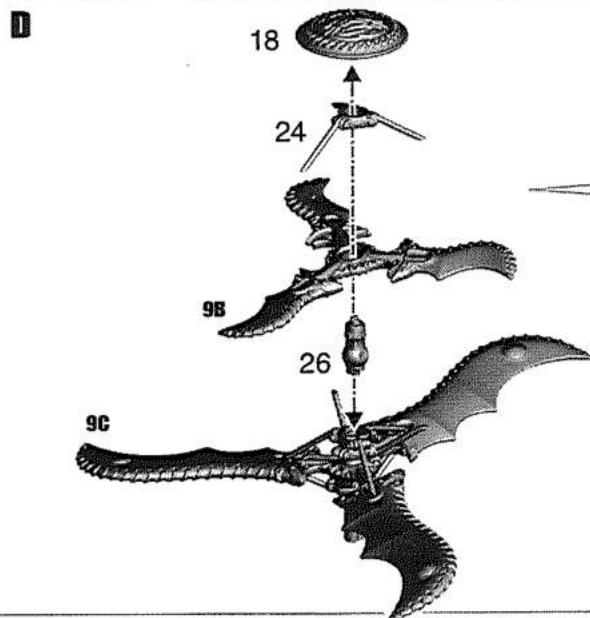
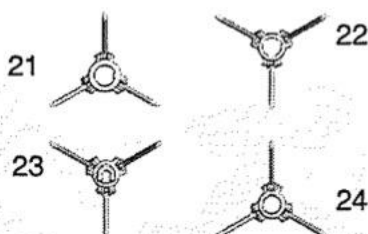

Assemble parts in order shown  
 Assembler les pièces dans l'ordre indiqué  
 Monta las piezas en el orden mostrado  
 Baue die Teile in der gezeigten Reihenfolge zusammen  
 Assembla i componenti nell'ordine indicato  
 図に示された順番でパーツを組み立てること

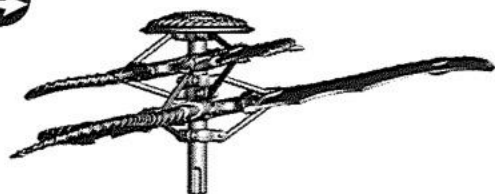
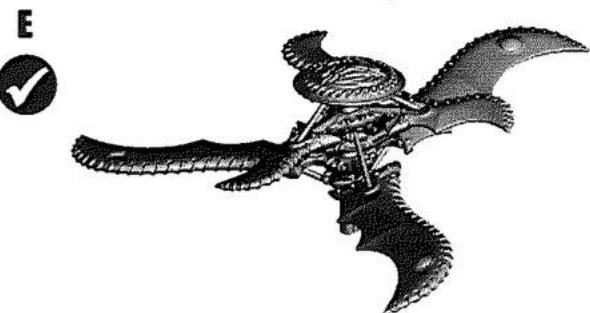
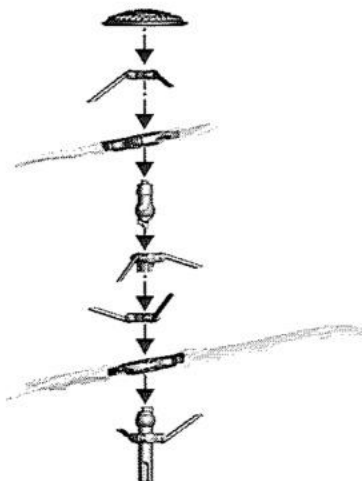

**10**

**ROTOR AND FLYING BASE ASSEMBLY • ASSEMBLAGE DU ROTOR ET DU SOCLE VOLANT • MONTAJE DEL ROTOR Y LA PEANA VOLADORA  
ANBRINGEN DES ROTORS UND DES FLUGBASES • ASSEMBLAGGIO DEL ROTORE E DELLA BASETTA PER MODELLI VOLANTI  
回転翼とフライングベースの組み立て**

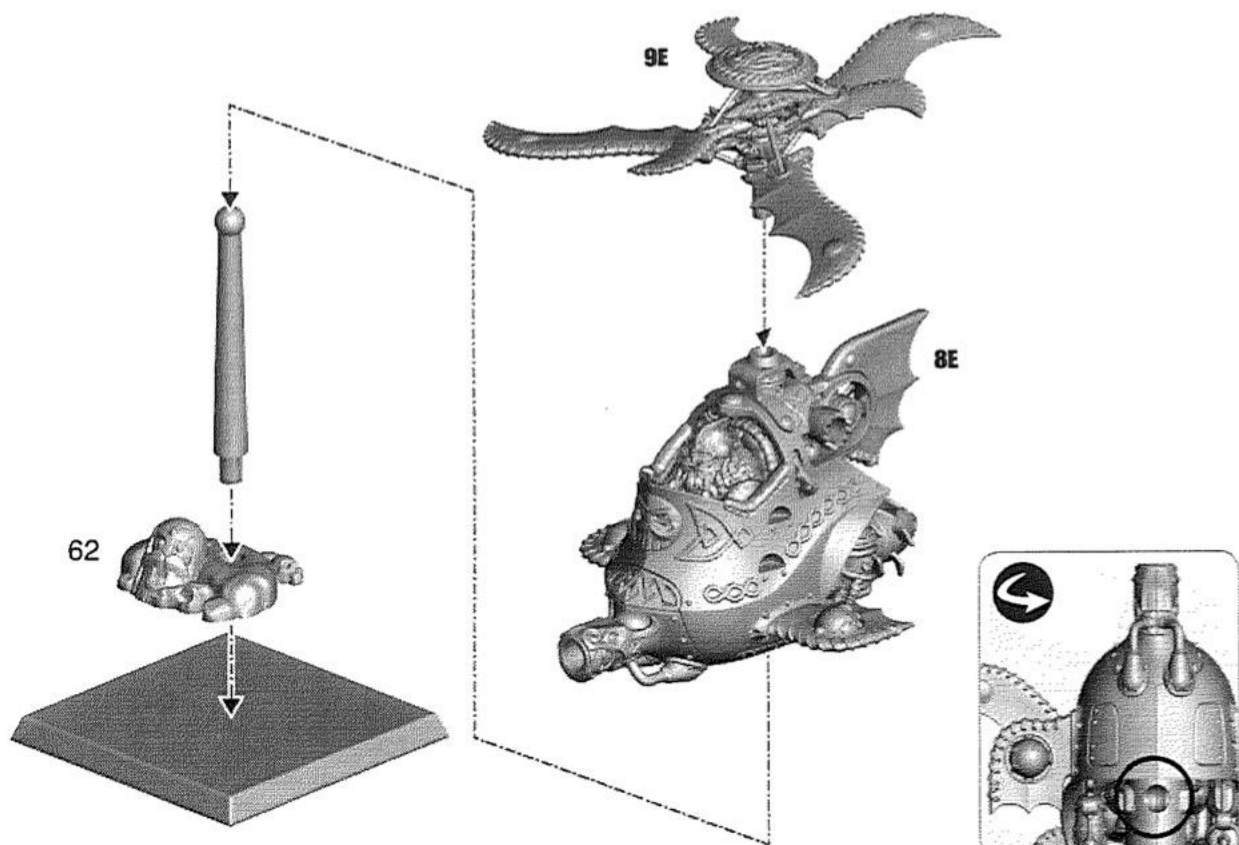

**FINISHED ASSEMBLY • ASSEMBLAGE TERMINÉ • MONTAJE ACABADO  
FERTIGER ZUSAMMENBAU • ASSEMBLAGGIO COMPLETO • 完成例**



DWARF GYROBOMBER • GYROBOMBARDIER NAIN • GIROBOMBARDERO ENANO  
GYROBOMBER DER ZWERGE • GIROBOMBARDIERE DEI NANI • ドワーフ ジャイロボマー

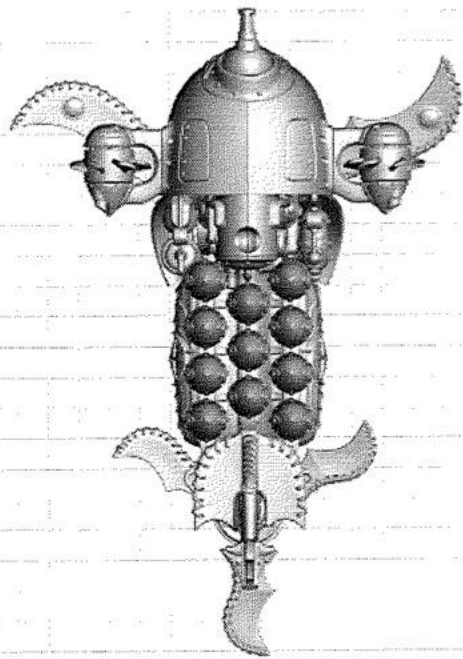
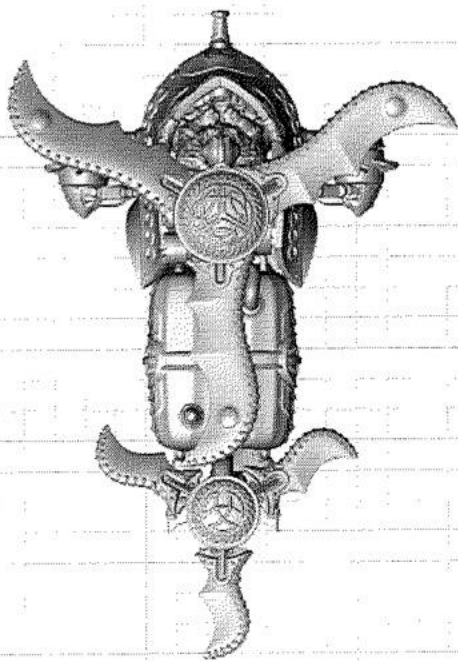
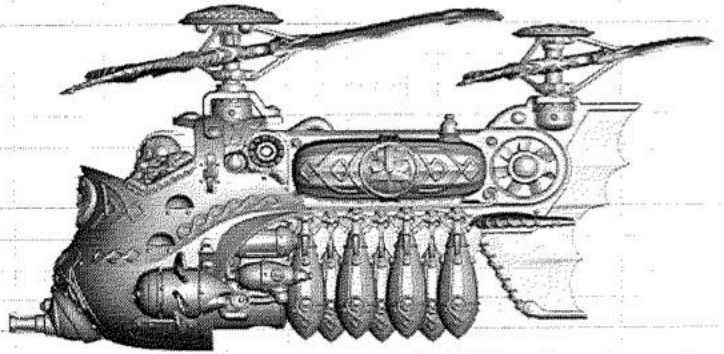
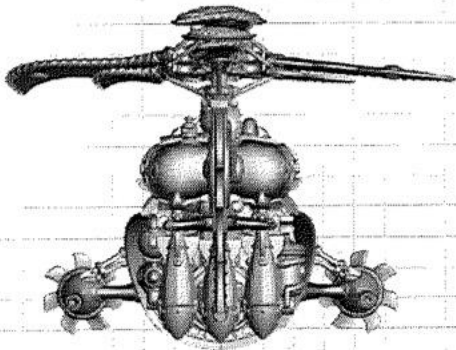
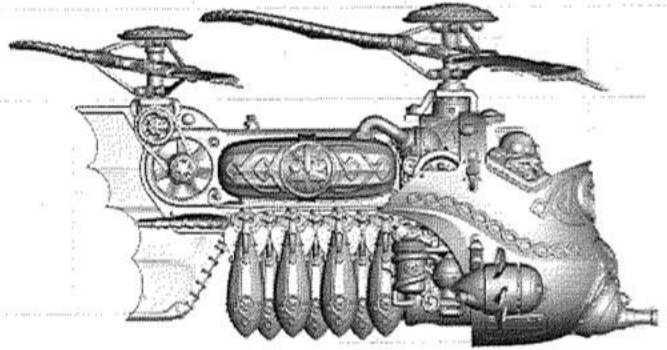
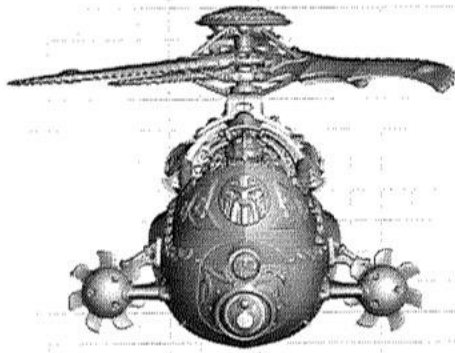



DWARF GYROCOPTER • GYROCOPTÈRE NAIN • GIROCOPTERO ENANO  
GYROKOPTER DER ZWERGE • GIROCOTTERO DEI NANI • ドワーフ ジャイロコプター

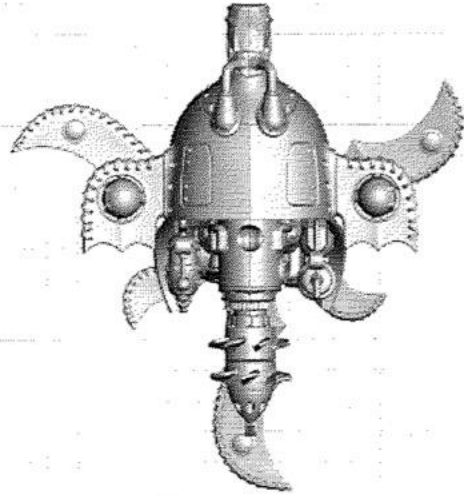
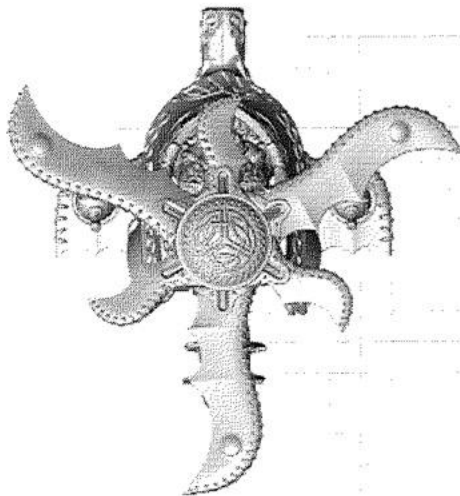
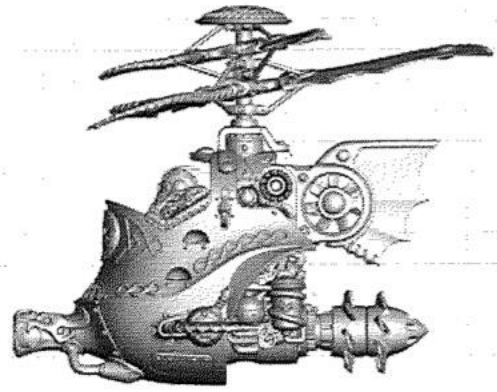
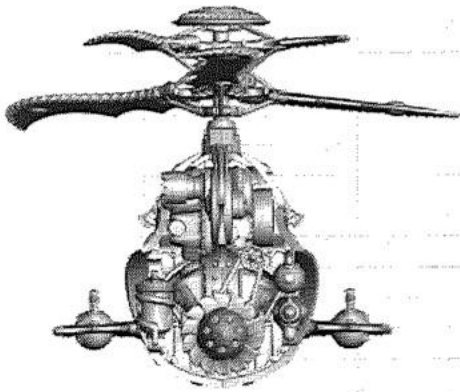
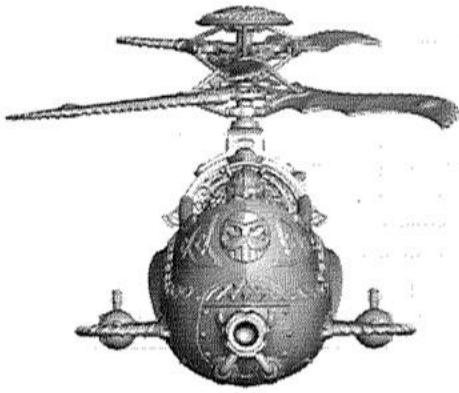

DWARF GYROBOMBER • GYROBOMBARDIER NAIN  
GIROBOMBARDEIRO ENANO • GYROBOMBER DER ZWERGE  
GIROBOMBARDIERE DEI NANI • ドワーフ ジャイロボマー

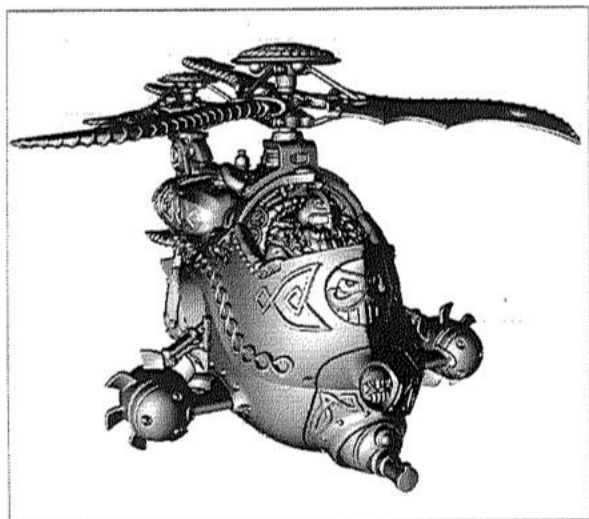

DWARF GYROCOPTER • GYROCOPTÈRE NAIN  
GIROCÓPTERO ENANO • GYROKOPTER DER ZWERGE  
GIROCOTTERO DEI NANI • ドワーフ ジャイロコプター

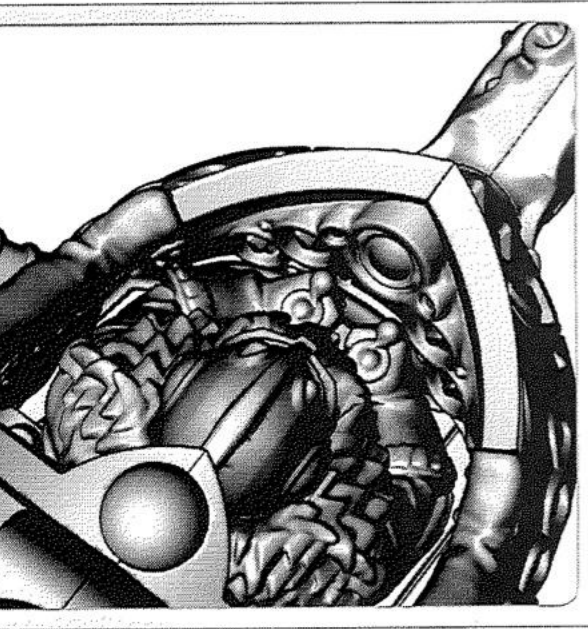
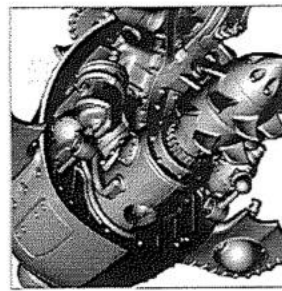
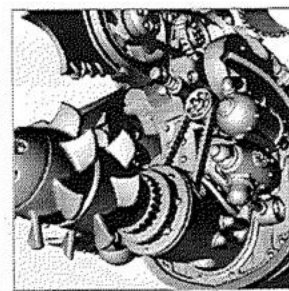
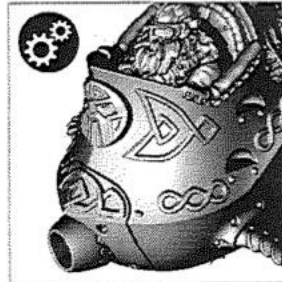
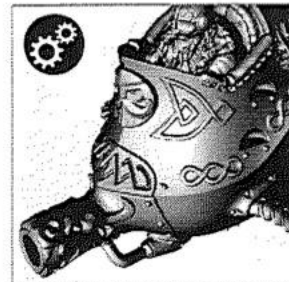
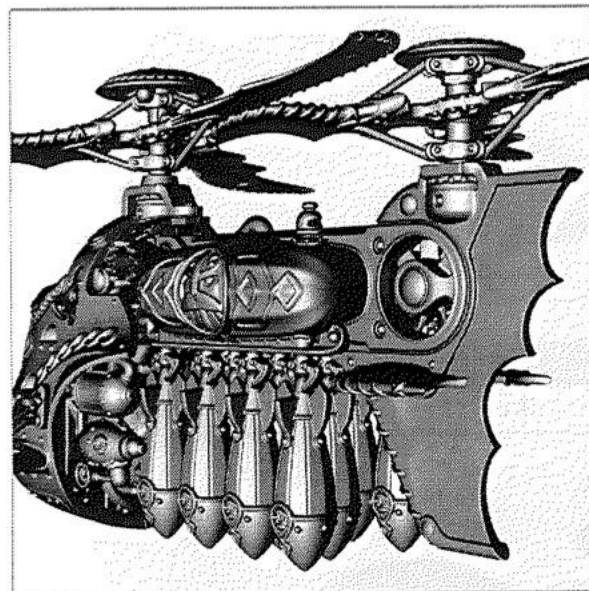
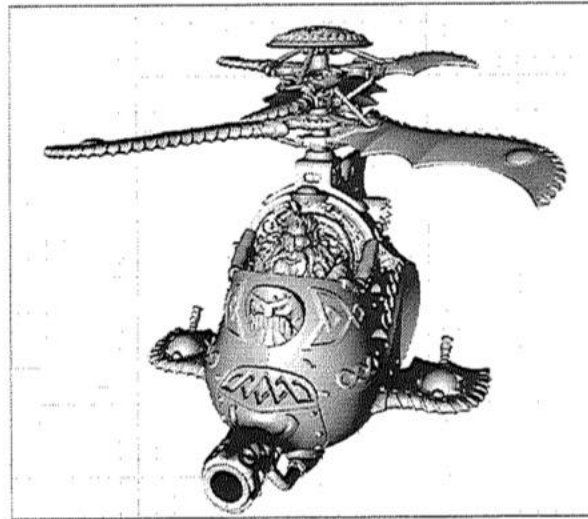

# DWARFS

	M	WS	BS	S	T	W	I	A	Ld	Troop Type
<b>Gyrobomber</b>	1	4	3	4	5	3	2	2	9	Unique

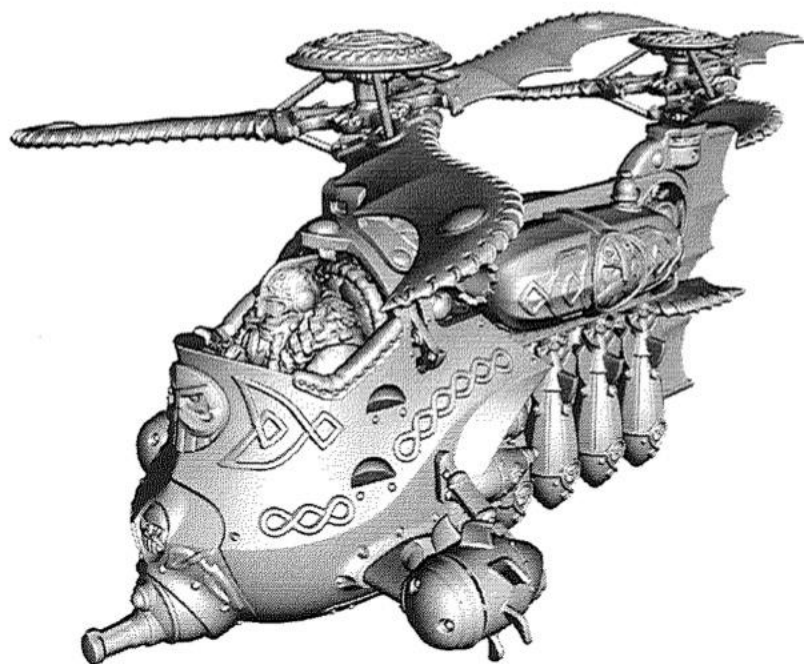

	M	WS	BS	S	T	W	I	A	Ld	Troop Type
<b>Gyrocopter</b>	1	4	3	4	5	3	2	2	9	Unique

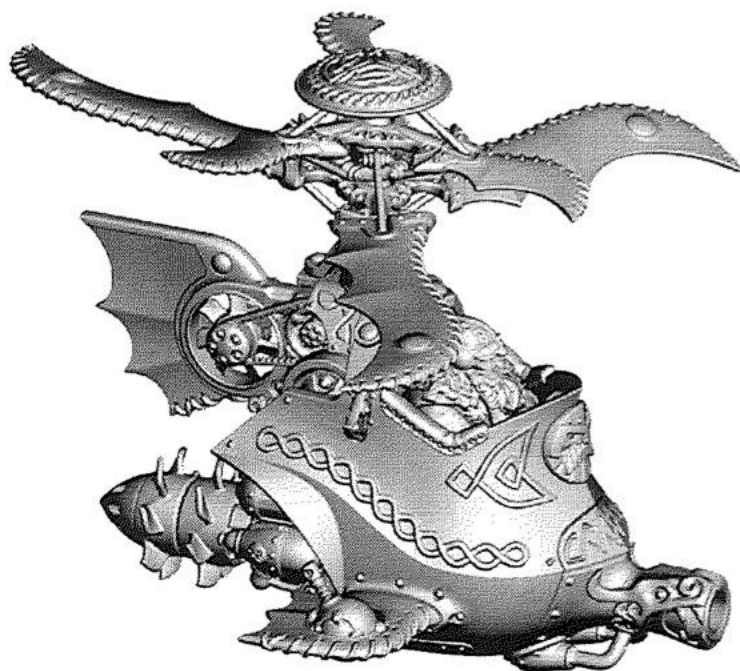

**WARHAMMER**