



Free Downloads of Build Instructions,
Assembly Booklets & How To Guides

BuildInstructions.com

WARHAMMER 40,000

CHOOSE THE VARIANT YOU WANT TO BUILD • CHOISISSEZ LA VARIANTE À ASSEMBLER • ELIGE QUÉ VERSIÓN QUIERES MONTAR
WÄHLE DIE VARIANTE, DIE DU BAUEN MÖCHTEST • SCEGLI LA VARIANTE CHE VUDI ASSEMBLARE

FORGEFIEND

STEPS • ÉTAPES • PASOS
SCHITTE • FASI
1 - 2



MAULERFIEND

STEPS • ÉTAPES • PASOS
SCHITTE • FASI
1 . 3





• **READ THIS FIRST** • **À LIRE EN PREMIER** • **LEER ANTES DE MONTAR**
 • **LIES D'ES ZUERST** • **LEGGI PRIMA QUESTO**

ENG BEFORE ASSEMBLING YOUR MINIATURES PLEASE READ THROUGH THE INSTRUCTIONS IN THIS BOOKLET CAREFULLY. A pair of plastic cutters is required to remove the plastic components in this kit from their frame. We advise using a mouldline scraping tool to clean up the parts. To assemble your model you will need plastic glue. Games Workshop sells Citadel Fine Detail Cutters, Citadel Mouldline Remover and Citadel Plastic Glue, but does not recommend these products for use by children under the age of 16 without adult supervision.

FRE AVANT D'ASSEMBLER VOS FIGURINES, VEUILLEZ LIRE ATTENTIVEMENT LES INSTRUCTIONS DE CE LIVRET. Une pince coupante est requise pour détacher chaque élément de sa grappe. Nous vous recommandons l'utilisation d'un grattoir pour ébarber les éléments. Pour l'assemblage, vous aurez également besoin de colle plastique. Games Workshop commercialise les Pinces de Précision Citadel, l'Ébarboir Citadel et la Colle Plastique Citadel, mais n'en recommande pas l'utilisation pour des enfants de moins de 16 ans sans la supervision d'un adulte.

SPA POR FAVOR, LEE CUIDADOSAMENTE ESTE LIBRETO DE INSTRUCCIONES ANTES DE EMPEZAR A MONTAR LAS MINIATURAS. Te harán falta unas tenazas para plástico a fin de separar las piezas de la matriz. También aconsejamos una herramienta para rebabas a fin de limpiar cada pieza. Para montar la miniatura necesitarás pegamento para plástico. Games Workshop vende Tenazas Citadel, Herramientas para rebabas Citadel y Pegamento para plástico Citadel, pero no recomienda estos productos a menores de 16 años sin la supervisión de un adulto.

GER VOR DEM ZUSAMMENBAU DER MINIATUREN BITTE DIE ANWEISUNGEN IN DIESER ANLEITUNG AUFMERKSAM DURCHLESEN. Du benötigst einen Kunststoffseitenschneider, um die Kunststoffbauteile aus dem Gussrahmen herauszutrennen, und Kunststoffkleber, um die Miniatur zusammenzubauen. Außerdem empfehlen wir, die Bauteile vorher mit einem Gussgratentferner zu säubern. Games Workshop bietet Präzisions-Kunststoffseitenschneider von Citadel sowie Citadel-Kunststoffkleber an, empfiehlt aber, dass Kinder unter 16 Jahren diese nur unter Aufsicht eines Erwachsenen benutzen.

ITA PRIMA DI ASSEMBLARE LE TUE MINIATURE LEGGI ATTENTAMENTE TUTTE LE ISTRUZIONI DI QUESTO LIBRETTO. Sono necessarie un paio di tronchesine per plastica per staccare i componenti dai loro sprue. Consigliamo di usare un attrezzo apposito per pulire i componenti. Per assemblare il modello avrai bisogno di colla per plastica. Games Workshop vende Tronchesine di precisione Citadel, Attrezzo per ripulire Citadel e Colla per plastica Citadel, ma non consiglia questi prodotti ad un pubblico minore di 16 anni senza la supervisione di un adulto.

• **EXPLANATION OF SYMBOLS** • **EXPLICATION DES SYMBOLES** • **EXPLICACIÓN DE SÍMBOLOS**
 • **ERLÄUTERUNG DER SYMBOLE** • **LEGENDA DEI SIMBOLI**



- Dry fit stage before gluing
- Tester avant de coller
- Comprobar el encaje antes de pegar
- Positionierung erst ohne Klebstoff ausprobieren
- Prova a secco prima di incollare



- Choice of parts
- Choix d'éléments
- Modelos de componentes
- Auswahl an Teilen
- Scelta di componenti



- Variant assembly
- Variante d'assemblage
- Variante de montaje
- Bauvariante
- Assemblaggio alternativo



• **FOLLOW STEP 1 FOR ALL VARIANTS**
 • **SUIVRE LES ÉTAPE 1 POUR TOUTES LES VARIANTES** • **SIGUE LOS PASOS 1 PARA TODAS LAS VARIANTES**
 • **FOLGE SCHRITT 1 FÜR ALLE VARIANTEN** • **SEGUI LA FASE 1 PER TUTTE LE VARIANTI**

1

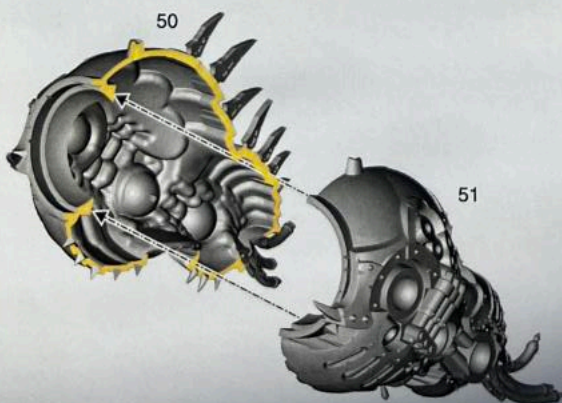

2 FORGEFIEND

2 a

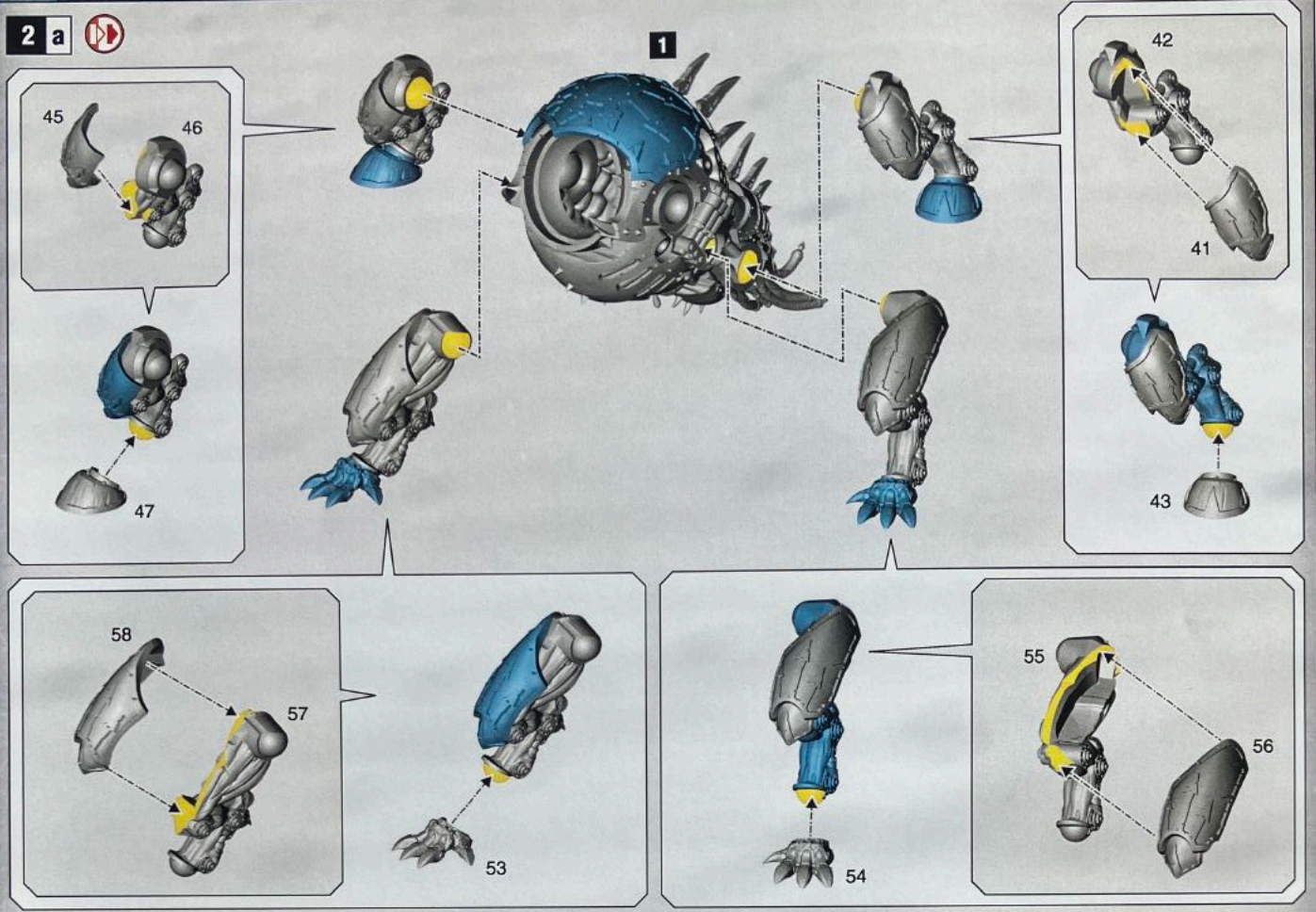

2 b

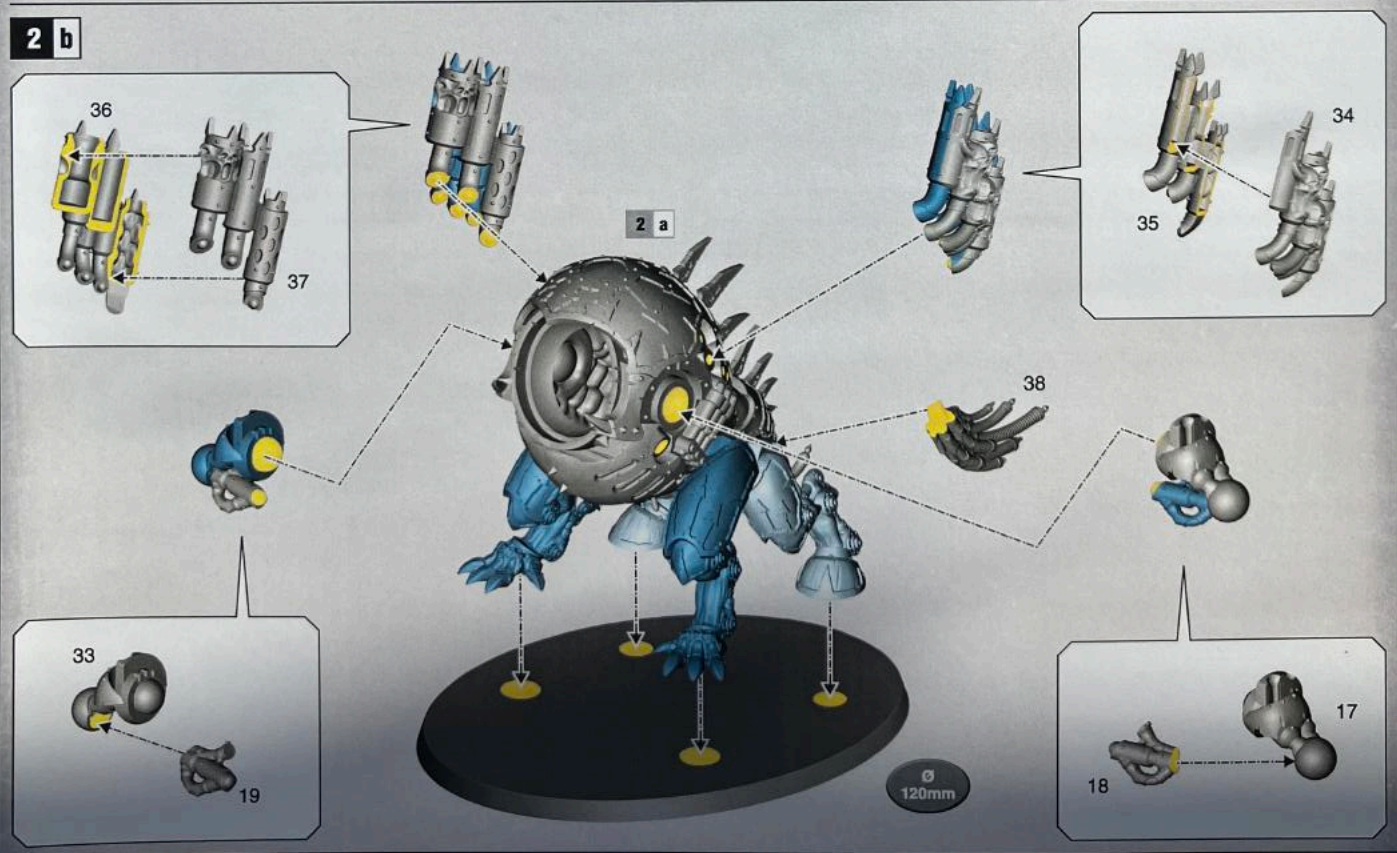

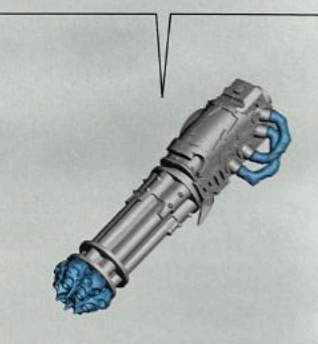
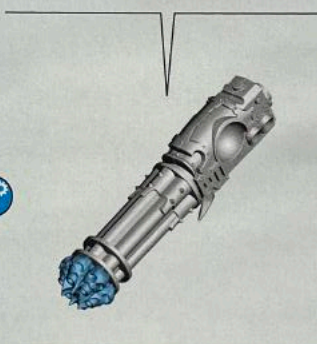
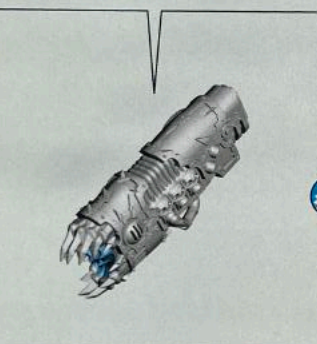
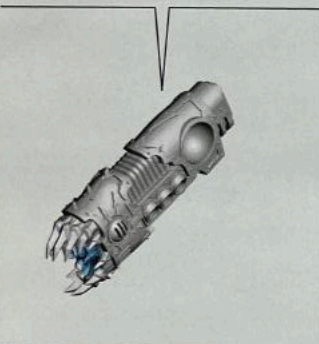
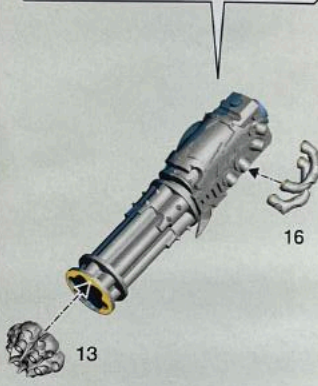
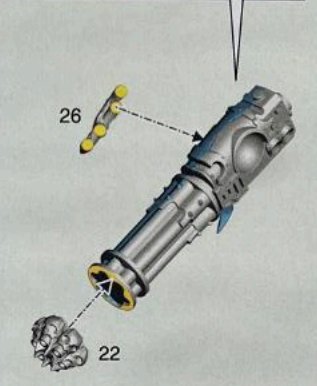
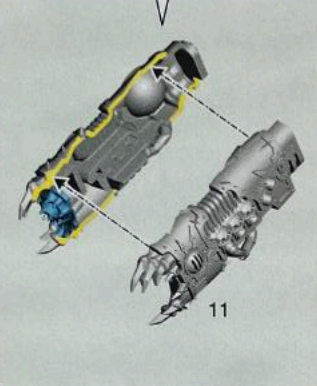
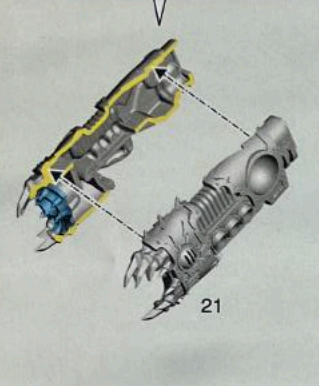
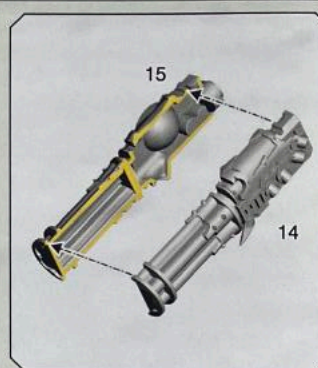
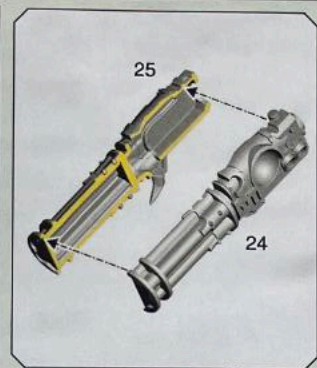
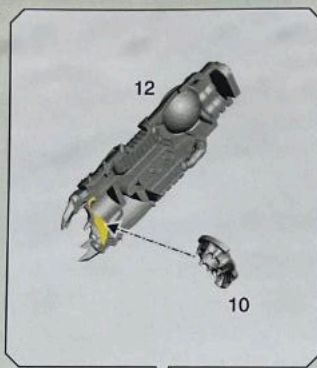
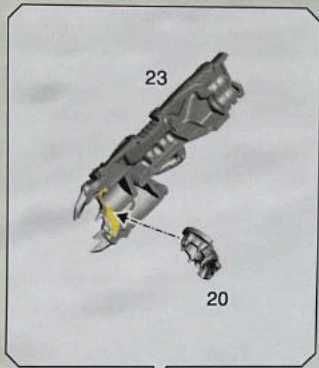

• Ectoplasma Cannon • Canon Ectoplasma • Cañón de ectoplasma
 • Ektoplasma-Kanone • Cannone ectoplasma

• Hades Autocannon • Autocanon Hades • Cañón automático Hades
 • Hades-Maschinenkanone • Cannone automatico hades

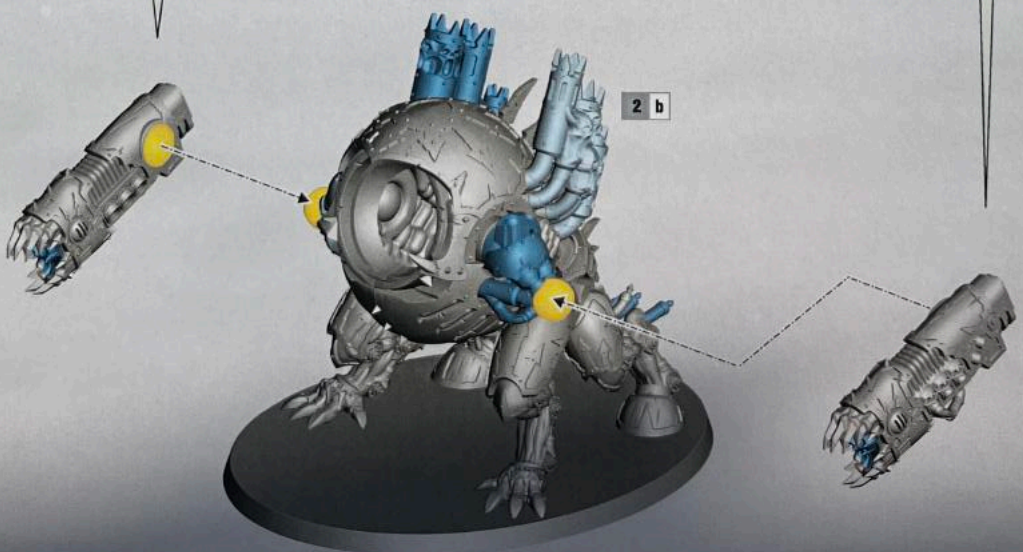

2 d

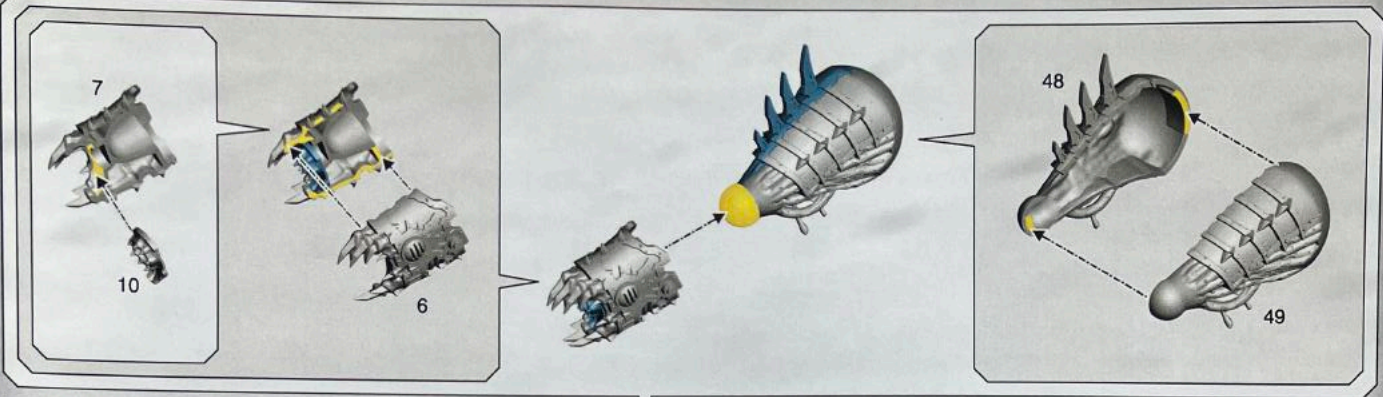

DAEMON JAWS

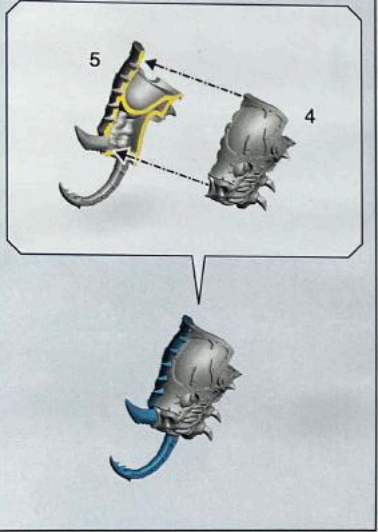

2 c

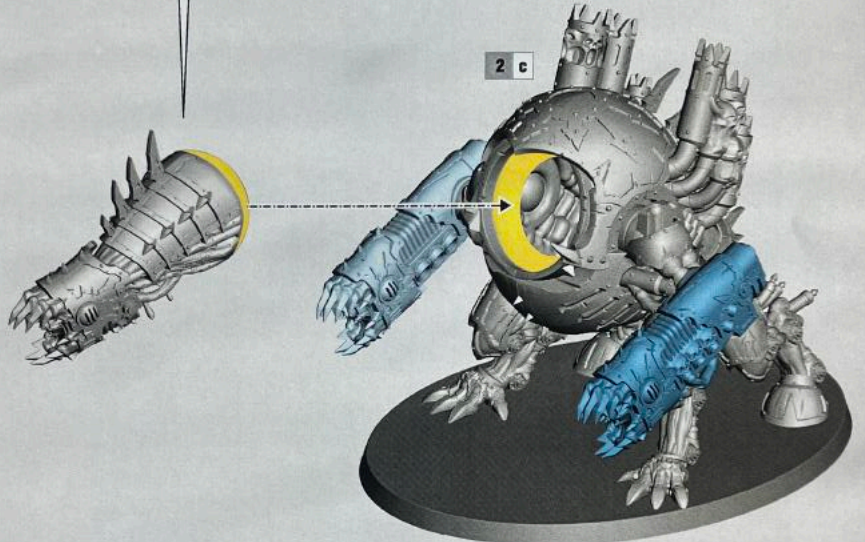

2 e

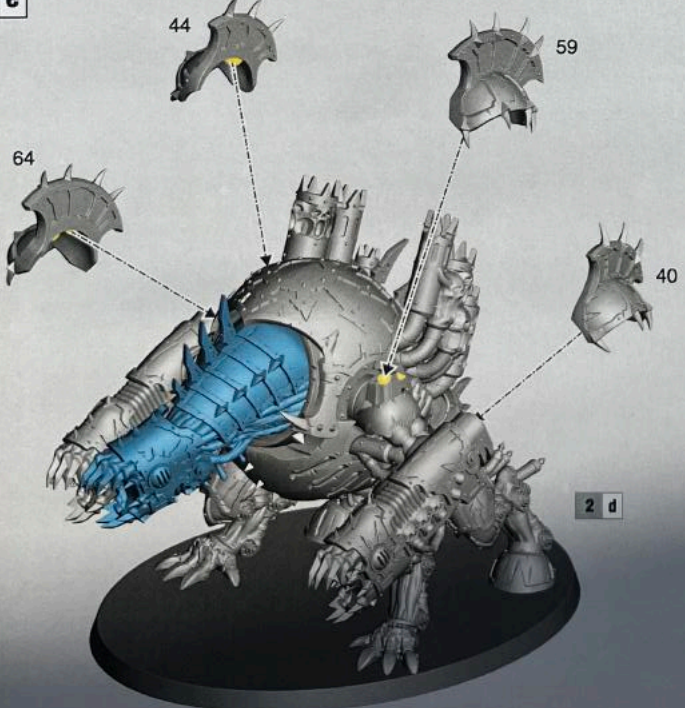

3 MAULERFIEND

3 a

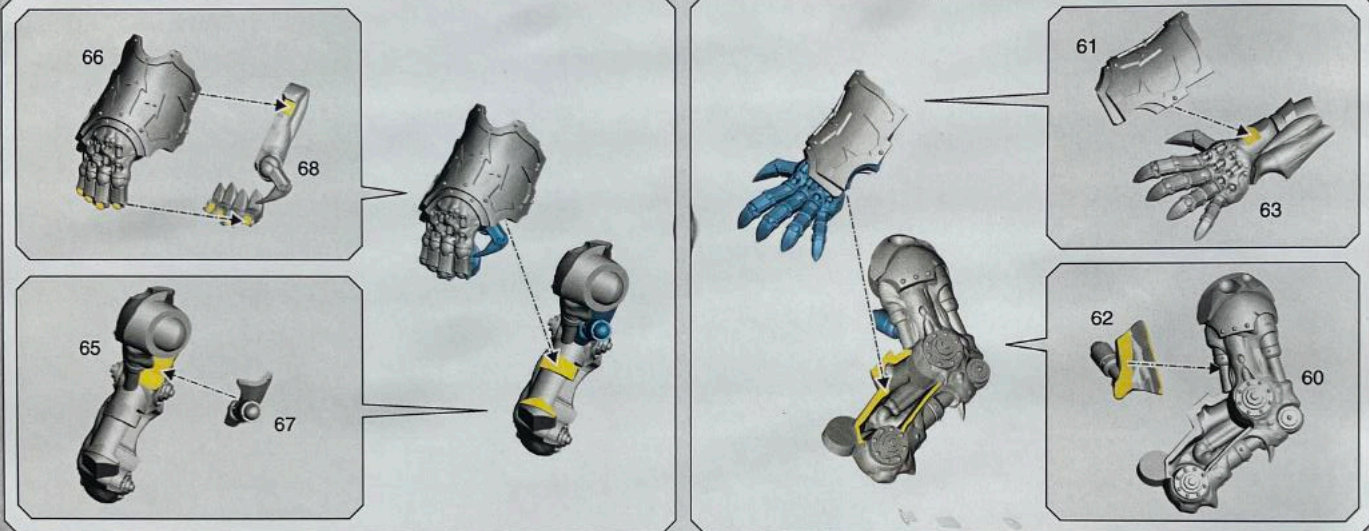
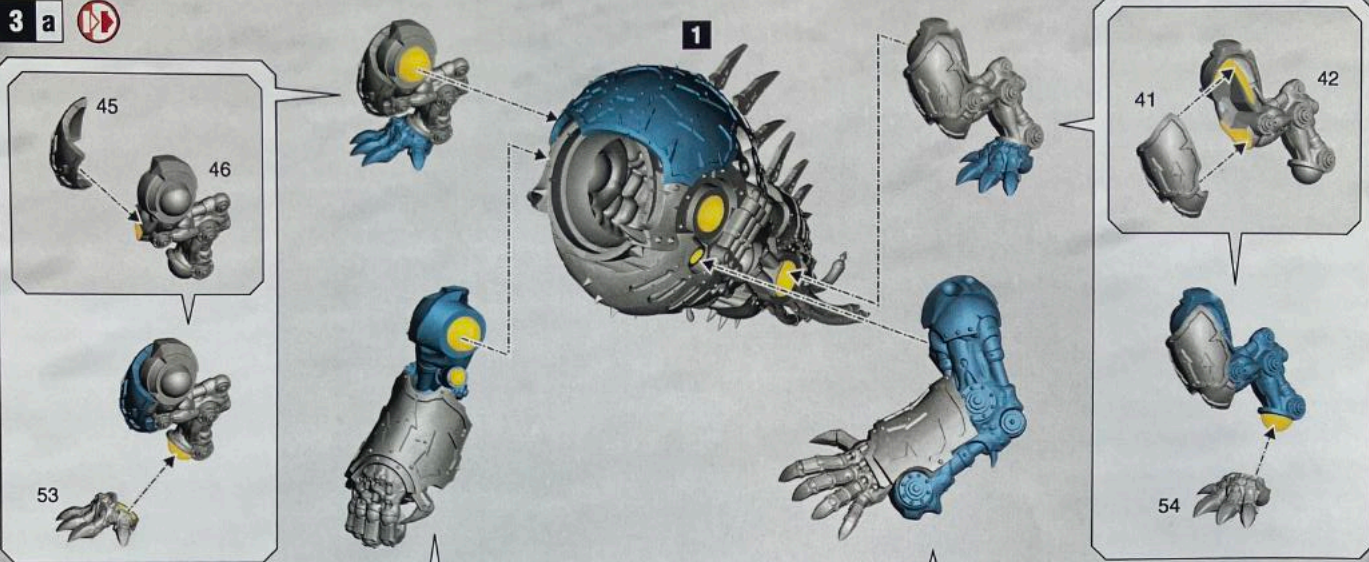

3 b



3 c

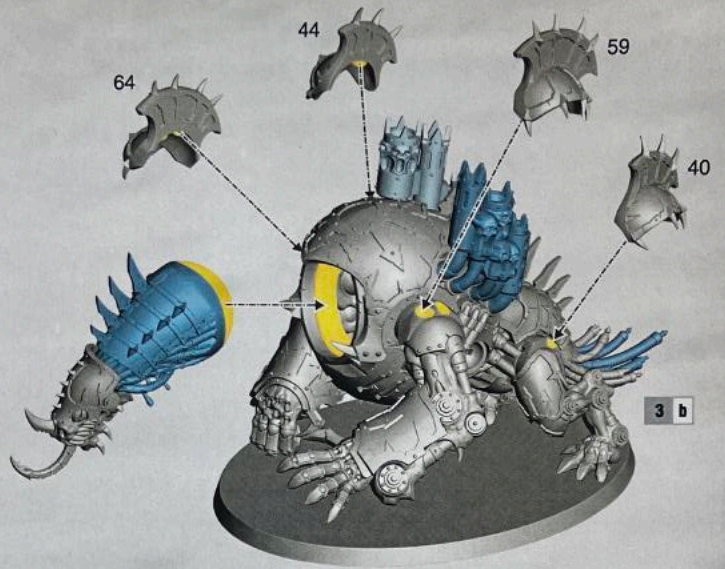
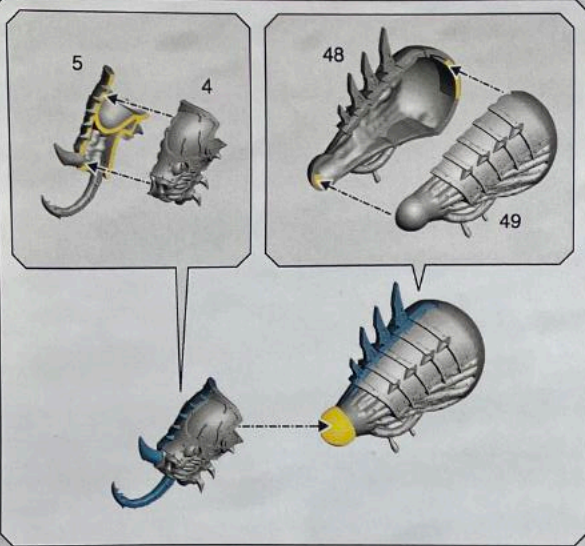

3 d

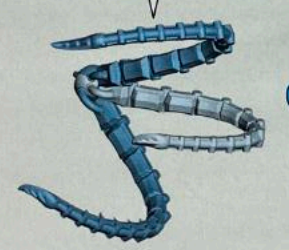
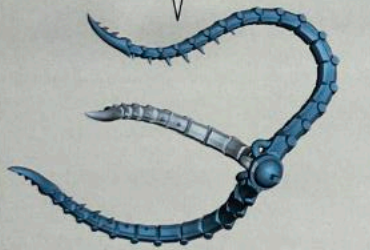
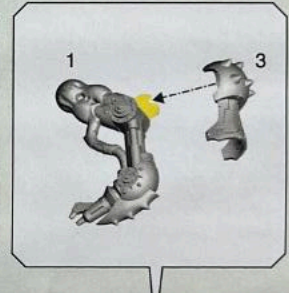
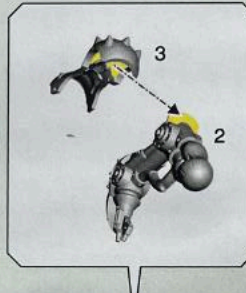
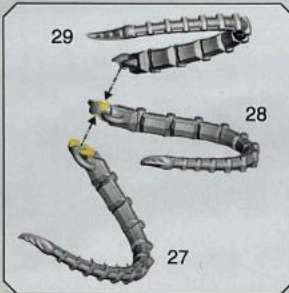
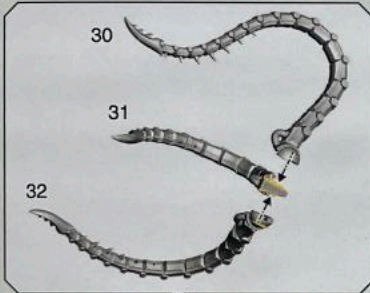

- Lasher tendrils • Mécaflagellums • Tentáculos azotadores
- Peitschententakel • Tentacoli costrittori

- Magma Cutter • Découpeur à magma • Cortador de magma
- Magmaschneider • Fresa magma

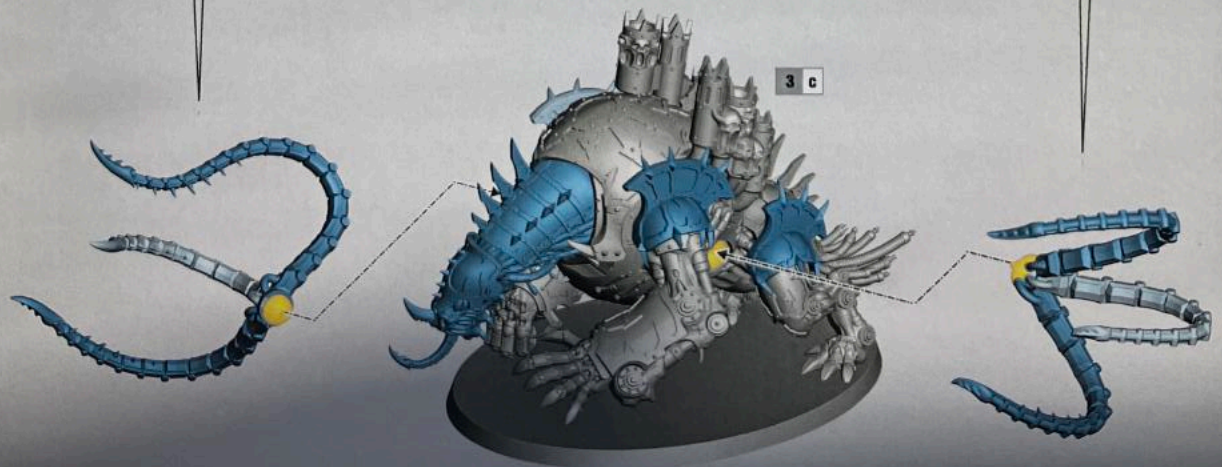

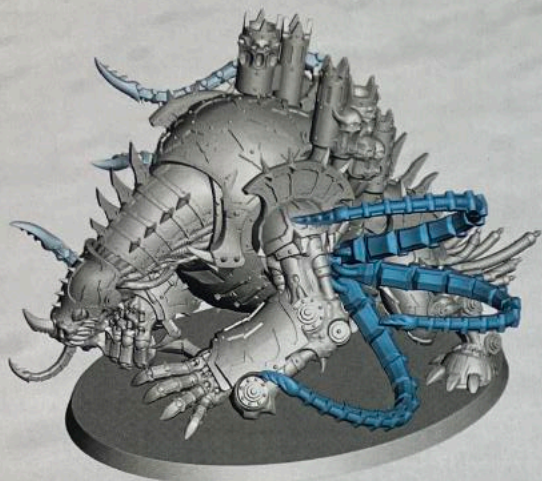

ENGLISH

These essential rules will get your new unit on the battlefield – for the full rules for this unit, see the codex relevant to your army.

FORGEFIEND

8
POWER

NAME	M	WS	BS	S	T	W	A	Ld	Sv
Forgefiend	*	4+	*	6	7	12	*	8	3+

A Forgefiend is a single model equipped with two Hades autocannons and Daemon jaws.

WEAPON	RANGE	TYPE	S	AP	D	ABILITIES
Ectoplasma cannon	24"	Heavy D3	7	-3	D3	-
Hades autocannon	36"	Heavy 4	8	-1	2	-
Daemon jaws	Melee	Melee	User	-1	2	-

WARGEAR OPTIONS

- This model may replace both Hades autocannons with ectoplasma cannons.
- This model may replace its Daemon jaws with an ectoplasma cannon.

ABILITIES

Daemonic: This model has a 5+ invulnerable save.**Infernal Regeneration:** At the start of your turn, this model regains 1 lost wound.**Explodes:** If this model is reduced to 0 wounds, roll a D6 before removing the model from the battlefield; on a 6 it explodes, and each unit within 6" suffers D3 mortal wounds.

FACTION KEYWORDS

CHAOS, <MARK OF CHAOS>, HERETIC ASTARTES, <LEGION>

KEYWORDS

VEHICLE, DAEMON, DAEMON ENGINE, FORGEFIEND

DAMAGE

Some of this model's characteristics change as it suffers damage, as shown below:

REMAINING W	M	BS	A
7-12+	8"	4+	4
4-6	6"	5+	3
1-3	4"	6+	2

MAULERFIEND

7
POWER

NAME	M	WS	BS	S	T	W	A	Ld	Sv
Maulerfiend	*	4+	4+	*	7	12	*	8	3+

A Maulerfiend is a single model equipped with Maulerfiend fists and two magma cutters.

WEAPON	RANGE	TYPE	S	AP	D	ABILITIES
Magma cutter	6"	Pistol 1	8	-4	3	-
Lasher tendrils	Melee	Melee	User	-2	2	Each time the bearer fights, it can make 6 additional attacks with this weapon.
Maulerfiend fists	Melee	Melee	x2	-3	3	-

WARGEAR OPTIONS

- This model may replace both magma cutters with lasher tendrils.

ABILITIES

Daemonic: This model has a 5+ invulnerable save.**Infernal Regeneration:** At the start of your turn, this model regains 1 lost wound.**Explodes:** If this model is reduced to 0 wounds, roll a D6 before removing the model from the battlefield; on a 6 it explodes, and each unit within 6" suffers D3 mortal wounds.

FACTION KEYWORDS

CHAOS, <MARK OF CHAOS>, HERETIC ASTARTES, <LEGION>

KEYWORDS

VEHICLE, DAEMON, DAEMON ENGINE, MAULERFIEND

DAMAGE

Some of this model's characteristics change as it suffers damage, as shown below:

REMAINING W	M	S	A
7-12+	10"	6	4
4-6	8"	5	3
1-3	6"	4	2

FORGEFIEND

8
 POISSANCE

NOM	M	CC	CT	F	E	PV	A	Cd	Sv
Forgefiend	*	4+	*	6	7	12	*	8	3+

Un Forgefiend est une figurine individuelle équipée de deux autocanons Hades et d'une mâchoire de démon.

DÉGÂTS

Certaines caractéristiques changent si des dégâts sont subis, comme indiqué ci-dessous :

PV RESTANTS	M	CT	A
7-12+	8"	4+	4
4-6	6"	5+	3
1-3	4"	6+	2

ARMES	PORTÉE	TYPE	F	PA	D	APTITUDES
Canon Ectoplasma	24"	Lourde D3	7	-3	D3	-
Autocanon Hades	36"	Lourde 4	8	-1	2	-
Mâchoire de démon	Mélée	Mélée	Util.	-1	2	-

OPTIONS D'ÉQUIPEMENT

- Cette figurine peut remplacer ses deux autocanons Hades par des canons Ectoplasma.
- Cette figurine peut remplacer sa mâchoire de démon par un canon Ectoplasma.

APTITUDES

Démoniaque: Cette figurine a une sauvegarde invulnérable de 5+.

Régénération Infernale: Au début de votre tour, cette figurine récupère 1 PV perdu.

Explosion: Si cette figurine est réduite à 0 PV, jetez un D6 avant de la retirer du champ de bataille; sur 6 elle explose, et chaque unité à 6" ou moins subit D3 blessures mortelles.

MOTS-CLÉS DE FACTION CHAOS, <MARQUE DU CHAOS>, HERETIC ASTARTES, <LÉGION>

MOTS-CLÉS VÉHICULE, DAEMON, MACHINE-DÉMON, FORGEFIEND

MAULERFIEND

7
 POISSANCE

NOM	M	CC	CT	F	E	PV	A	Cd	Sv
Maulerfiend	*	4+	4+	*	7	12	*	8	3+

Un Maulerfiend est une figurine individuelle équipée de poings de Maulerfiend et de deux découpeurs à magma.

DÉGÂTS

Certaines caractéristiques changent si des dégâts sont subis, comme indiqué ci-dessous :

PV RESTANTS	M	CT	A
7-12+	10"	6	4
4-6	8"	5	3
1-3	6"	4	2

ARMES	PORTÉE	TYPE	F	PA	D	APTITUDES
Découpeur à magma	6"	Pistolet 1	8	-4	3	-
Mécaflagellums	Mélée	Mélée	Util.	-2	2	Chaque fois que le porteur combat, il peut effectuer 6 attaques supplémentaires avec cette arme.
Poings de Maulerfiend	Melee	Melee	x2	-3	3	-

OPTIONS D'ÉQUIPEMENT

- Cette figurine peut remplacer ses deux découpeurs à magma par des mécaflagellums.

APTITUDES

Démoniaque: Cette figurine a une sauvegarde invulnérable de 5+.

Régénération Infernale: Au début de votre tour, cette figurine récupère 1 PV perdu.

Explosion: Si cette figurine est réduite à 0 PV, jetez un D6 avant de la retirer du champ de bataille; sur 6 elle explose, et chaque unité à 6" ou moins subit D3 blessures mortelles.

MOTS-CLÉS DE FACTION CHAOS, <MARQUE DU CHAOS>, HERETIC ASTARTES, <LÉGION>

MOTS-CLÉS VÉHICULE, DAEMON, MACHINE-DÉMON, MAULERFIEND

FORGEFIEND



NOMBRE	M	HA	HP	F	R	H	A	L	S
Forgefiend	*	4+	*	6	7	12	*	8	3+

Un Forgefiend es una sola miniatura equipada con dos cañones automáticos Hades y fauces daemónicas.

ARMA	ALC.	TIPO	F	FP	D	HABILIDADES
Cañón de ectoplasma	24"	Pesada 1D3	7	-3	1D3	-
Cañón automático Hades	36"	Pesada 4	8	-1	2	-
Fauces daemónicas	Com.	Combate	Port.	-1	2	-

OPCIONES DE EQUIPO

- Esta miniatura puede cambiar ambos cañones automáticos Hades por cañones de ectoplasma.
- Esta miniatura puede cambiar las fauces daemónicas por un cañón de ectoplasma.

HABILIDADES

Daemónico. Esta miniatura tiene una salvación invulnerable de 5+.

Regeneración infernal. Al inicio de tu turno, esta miniatura recupera 1 herida perdida.

Explosión. Si las heridas de esta miniatura se reducen a 0, tira 1D6 antes de retirarla del campo de batalla; con un 6 explota y cada unidad a 6" o menos sufre 1D3 heridas mortales.

CLAVES DE FACCIÓN CHAOS, <MARCA DEL CHAOS>, HERETIC ASTARTES, <LEGIÓN>

CLAVES VEHÍCULO, DAEMON, INGENIO DAEMÓNICO, FORGEFIEND

DAÑO
Ciertos atributos de esta miniatura cambian cuando sufre daño, como indica esta tabla:

H RESTANTES	M	HP	A
7-12+	8"	4+	4
4-6	6"	5+	3
1-3	4"	6+	2

MAULERFIEND



NOMBRE	M	HA	HP	F	R	H	A	L	S
Maulerfiend	*	4+	4+	*	7	12	*	8	3+

Un Maulerfiend es una sola miniatura equipada con puños de Maulerfiend y dos cortadores de magma.

ARMA	ALC.	TIPO	F	FP	D	HABILIDADES
Cortador de magma	6"	Pistola 1	8	-4	3	-
Tentáculos azotadores	Com.	Combate	Port.	-2	2	Cada vez que el portador lucha puede hacer 6 ataques adicionales con esta arma.
Puños de Maulerfiend	Com.	Combate	x2	-3	3	-

OPCIONES DE EQUIPO

- Esta miniatura puede cambiar los dos cortadores de magma por tentáculos azotadores.

HABILIDADES

Daemónico. Esta miniatura tiene una salvación invulnerable de 5+.

Regeneración infernal. Al inicio de tu turno, esta miniatura recupera 1 herida perdida.

Explosión. Si las heridas de esta miniatura se reducen a 0, tira 1D6 antes de retirarla del campo de batalla; con un 6 explota y cada unidad a 6" o menos sufre 1D3 heridas mortales.

CLAVES DE FACCIÓN CHAOS, <MARCA DEL CHAOS>, HERETIC ASTARTES, <LEGIÓN>

CLAVES VEHÍCULO, DAEMON, INGENIO DAEMÓNICO, MAULERFIEND

DAÑO
Ciertos atributos de esta miniatura cambian cuando sufre daño, como indica esta tabla:

H RESTANTES	M	F	A
7-12+	10"	6	4
4-6	8"	5	3
1-3	6"	4	2

FORGEFIEND

8
MACHT

NAME	B	KG	BF	S	W	LP	A	MW	RW
Forgefiend	*	4+	*	6	7	12	*	8	3+

Ein Forgefiend ist ein einzelnes Modell, das mit zwei Hades-Maschinenkanonen und Dämonenkiefern ausgerüstet ist.

WAFFE	REICHW.	TYP	S	DS	SW	FÄHIGKEITEN
Ektoplasma-Kanone	24"	Schwer W3	7	-3	W3	-
Hades-Maschinenkanone	36"	Schwer 4	8	-1	2	-
Dämonenkiefer	Nahkampf	Nahkampf	Träger	-1	2	-

AUSRÜSTUNGSOPTIONEN

- Dieses Modell darf beide Hades-Maschinenkanonen durch Ektoplasma-Kanonen ersetzen.
- Dieses Modell darf seine Dämonenkiefer durch eine Ektoplasma-Kanone ersetzen.

FÄHIGKEITEN

Dämonisch: Dieses Modell hat einen Rettungswurf von 5+.

Infernale Regeneration: Zu Beginn deines Zugs erhält dieses Modell 1 verlorenen Lebenspunkt zurück.

Explosion: Wenn dieses Modell auf 0 Lebenspunkte reduziert wird, wirf einen Würfel, bevor das Modell vom Schlachtfeld entfernt wird; bei einer 6 explodiert es und jede Einheit innerhalb von 6 Zoll erleidet W3 tödliche Verwundungen.

FRAKTION CHAOS, <MAL DES CHAOS>, HERETIC ASTARTES, <LEGION>

SCHLÜSSELWÖRTER FAHRZEUG, DAEMON, DÄMONENMASCHINE, FORGEFIEND

SCHADEN

Manche Werte dieses Modells ändern sich, wenn es in der Schlacht Schaden erleidet:

ÜBRIGE LP	B	BF	A
7-12+	8"	4+	4
4-6	6"	5+	3
1-3	4"	6+	2

MAULERFIEND

7
MACHT

NAME	B	KG	BF	S	W	LP	A	MW	RW
Maulerfiend	*	4+	4+	*	7	12	*	8	3+

Ein Maulerfiend ist ein einzelnes Modell, das mit Maulerfiend-Fäusten und zwei Magmaschneidern ausgerüstet ist.

WAFFE	REICHW.	TYP	S	DS	SW	FÄHIGKEITEN
Magmaschneider	6"	Pistole 1	8	-4	3	-
Maulerfiend-Fäuste	Nahkampf	Nahkampf	x2	-3	3	-
Peitschentakel	Nahkampf	Nahkampf	Träger	-2	2	Jedes Mal, wenn der Träger kämpft, kann er 6 zusätzliche Attacken mit dieser Waffe durchführen.

AUSRÜSTUNGSOPTIONEN

- Dieses Modell darf seine beiden Magmaschneider durch Peitschentakel ersetzen.

FÄHIGKEITEN

Dämonisch: Dieses Modell hat einen Rettungswurf von 5+.

Infernale Regeneration: Zu Beginn deines Zugs erhält dieses Modell 1 verlorenen Lebenspunkt zurück.

Explosion: Wenn dieses Modell auf 0 Lebenspunkte reduziert wird, wirf einen Würfel, bevor das Modell vom Schlachtfeld entfernt wird; bei einer 6 explodiert es und jede Einheit innerhalb von 6 Zoll erleidet W3 tödliche Verwundungen.

FRAKTION CHAOS, <MAL DES CHAOS>, HERETIC ASTARTES, <LEGION>

SCHLÜSSELWÖRTER FAHRZEUG, DAEMON, DÄMONENMASCHINE, MAULERFIEND

SCHADEN

Manche Werte dieses Modells ändern sich, wenn es in der Schlacht Schaden erleidet:

ÜBRIGE LP	B	S	A
7-12+	10"	6	4
4-6	8"	5	3
1-3	6"	4	2

FORGEFIEND



NOME	M	AC	AB	Fo	R	Fe	A	D	S
Forgefiend	*	4+	*	6	7	12	*	8	3+

Un Forgefiend è un singolo modello equipaggiato con due cannoni automatici hades e fauci demoniache.

ARMI	GITTATA	TIPO	Fo	VP	Da	ABILITÀ
Cannone ectoplasma	24"	Pesante D3	7	-3	D3	-
Cannone automatico hades	36"	Pesante 4	8	-1	2	-
Fauci demoniache	Mischia	Mischia	Mod.	-1	2	-

OPZIONI DI EQUIPAGGIAMENTO

- Sostituire entrambi i cannoni automatici hades con cannoni ectoplasma.
- Sostituire le fauci demoniache con un cannone ectoplasma.

ABILITÀ

Demonico: questo modello ha un tiro invulnerabilità di 5+. **Esplode:** se questo modello viene ridotto a 0 ferite tira un D6 prima di rimuoverlo dal campo di battaglia; con 6 esplode e ogni unità entro 6" subisce D3 ferite mortali.

Rigenerazione Infernale: all'inizio di ciascuno dei tuoi turni questo modello sana una ferita.

KEYWORDS DI FAZIONE CHAOS, <MARCHIO DEL CHAOS>, HERETIC ASTARTES, <LEGIONE>

KEYWORDS VEICOLO, DAEMON, MACCHINA DEMONIACA, FORGEFIEND

DANNI

Alcune caratteristiche di questo modello cambiano come segue man mano che subisce danni:

FE RIMANENTI	M	AB	A
7-12+	8"	4+	4
4-6	6"	5+	3
1-3	4"	6+	2

MAULERFIEND



NOME	M	AC	AB	Fo	R	Fe	A	D	S
Maulerfiend	*	4+	4+	*	7	12	*	8	3+

Un Maulerfiend è un singolo modello equipaggiato con magli del Maulerfiend e due frese magma.

ARMI	GITTATA	TIPO	Fo	VP	Da	ABILITÀ
Fresa magma	6"	Pistola 1	8	-4	3	-
Tentacoli costrittori	Mischia	Mischia	Mod.	-2	2	Ogni volta che il portatore combatte può effettuare 6 attacchi addizionali con quest'arma.
Magli del Maulerfiend	Mischia	Mischia	x2	-3	3	-

OPZIONI DI EQUIPAGGIAMENTO

- Sostituire entrambe le frese magma con tentacoli costrittori.

ABILITÀ

Demonico: questo modello ha un tiro invulnerabilità di 5+. **Esplode:** se questo modello viene ridotto a 0 ferite tira un D6 prima di rimuoverlo dal campo di battaglia; con 6 esplode e ogni unità entro 6" subisce D3 ferite mortali.

Rigenerazione Infernale: all'inizio di ciascuno dei tuoi turni questo modello sana una ferita.

KEYWORDS DI FAZIONE CHAOS, <MARCHIO DEL CHAOS>, HERETIC ASTARTES, <LEGIONE>

KEYWORDS VEICOLO, DAEMON, MACCHINA DEMONIACA, FORGEFIEND

DANNI

Alcune caratteristiche di questo modello cambiano come segue man mano che subisce danni:

FE RIMANENTI	M	Fo	A
7-12+	10"	6	4
4-6	8"	5	3
1-3	6"	4	2